



SERVICE STATION MANUAL

2Q000193



V9 Roamer - V9 Bobber



SERVICE STATION MANUAL

V9 Roamer - V9 Bobber

THE VALUE OF SERVICE

As a result of continuous updates and specific technical training programmes for Moto Guzzi products, only **Moto Guzzi** Official Network mechanics know this vehicle fully and have the specific tools necessary to carry out maintenance and repair operations correctly.

The reliability of the vehicle also depends on its mechanical conditions. Checking the vehicle before riding it, its regular maintenance and the use of **original Moto Guzzi spare parts** only are essential factors!

For information on the nearest **Official Dealer and/or Service Centre** consult our website:

www.motoguzzi.com

Only by requesting Moto Guzzi original spare parts can you be sure of purchasing products that were developed and tested during the actual vehicle design stage. All Moto Guzzi original spare parts undergo quality control procedures to guarantee reliability and durability.

The descriptions and images in this publication are given for illustrative purposes only and are not binding. While the basic characteristics as described and illustrated in this booklet remain unchanged, Piaggio & C. S.p.A. reserves the right, at any time and without being required to update this publication beforehand, to make any changes to components, parts or accessories, which it considers necessary to improve the product or which are required for manufacturing or construction reasons.

Not all versions/models shown in this publication are available in all countries. The availability of individual versions should be checked with the Official Moto Guzzi sales network.

The Moto Guzzi brand is owned by Piaggio & C. S.p.A.

© Copyright 2016 - Piaggio & C. S.p.A. All rights reserved. Reproduction of this publication in whole or in part is prohibited.

Piaggio & C. S.p.A. Viale Rinaldo Piaggio, 25 - 56025 PONTEDERA (PI), Italy

www.piaggio.com

SERVICE STATION MANUAL

V9 Roamer - V9 Bobber

This manual provides the main information to carry out regular maintenance operations on your vehicle. This manual is intended to Moto Guzzi Dealers and their qualified mechanics; several concepts have been deliberately omitted as they are considered unnecessary. As it is not possible to include complete mechanical notions in this manual, users should have basic mechanical knowledge or minimum knowledge about the procedures involved when repairing scooters. Without this knowledge, repairing or checking the vehicle may be inefficient or even dangerous. As the vehicle repair and check procedures are not described in detail, be extremely cautious so as not to damage components or injure individuals. In order to optimise customer satisfaction when using our vehicles, Moto Guzzi commits itself to continually improve its products and the relative documentation. The main technical modifications and changes in repair procedures are communicated to all Moto Guzzi Sales Outlets and its International Subsidiaries. These changes will be introduced in the subsequent editions of the manual. In case of need or further queries on repair and check procedures, consult Moto Guzzi CUSTOMER DEPARTMENT, which will be prepared to provide any information on the subject and any further communications on updates and technical changes related to the vehicle.

NOTE Provides key information to make the procedure easier to understand and carry out.

CAUTION Refers to specific procedures to carry out for preventing damages to the vehicle.

WARNING Refers to specific procedures to carry out to prevent injuries to the repairer.



Personal safety Failure to completely observe these instructions will result in serious risk of personal injury.



Safeguarding the environment Sections marked with this symbol indicate the correct use of the vehicle to prevent damaging the environment.



Vehicle intactness The incomplete or non-observance of these regulations leads to the risk of serious damage to the vehicle and sometimes even the invalidity of the guarantee



INDEX OF TOPICS

CHARACTERISTICS

CHAR

SPECIAL TOOLS

S-TOOLS

MAINTEENANCE

MAIN

ELECTRICAL SYSTEM

ELE SYS

ENGINE FROM VEHICLE

ENG VE

ENGINE

ENG

POWER SUPPLY

P SUPP

SUSPENSIONS

SUSP

CHASSIS

CHAS

BRAKING SYSTEM

BRAK SYS

BODYWORK

BODYW

PRE-DELIVERY

PRE DE

INDEX OF TOPICS

CHARACTERISTICS

CHAR

Rules

Safety rules

Carbon monoxide

If you need to keep the engine running while working on the vehicle, please ensure that you do so in an open or very well ventilated area. Never run the engine in an enclosed area. If you do work in an enclosed area, make sure to use a fume extraction system.

CAUTION



EXHAUST EMISSIONS CONTAIN CARBON MONOXIDE, A POISONOUS GAS WHICH CAN CAUSE LOSS OF CONSCIOUSNESS AND EVEN DEATH.

Fuel

CAUTION



**THE FUEL USED TO POWER INTERNAL COMBUSTION ENGINES IS HIGHLY FLAMMABLE AND MAY BE EXPLOSIVE UNDER CERTAIN CONDITIONS. IT IS THEREFORE RECOMMENDED TO CARRY OUT REFUELLING AND MAINTENANCE PROCEDURES IN A VENTILATED AREA WITH THE ENGINE SWITCHED OFF. DO NOT SMOKE DURING REFUELLING AND NEAR FUEL VAPOURS, AVOIDING ANY CONTACT WITH NAKED FLAMES, SPARKS OR OTHER SOURCES WHICH MAY CAUSE THEM TO IGNITE OR EXPLODE.
DO NOT DISPERSE FUEL IN THE ENVIRONMENT.
KEEP OUT OF THE REACH OF CHILDREN**

Hot components

The engine and the exhaust system components become very hot and remain hot for some time after the engine has been switched off. When handling these components, wear insulating gloves or wait until the engine and the exhaust system have cooled down.

Used engine oil and transmission oil

CAUTION



**IT IS ADVISABLE TO WEAR PROTECTIVE IMPERMEABLE GLOVES WHEN SERVICING THE VEHICLE.
THE ENGINE OR GEARBOX OIL MAY CAUSE SERIOUS INJURIES TO THE SKIN IF HANDLED FOR PROLONGED PERIODS OF TIME AND ON A REGULAR BASIS.
WASH YOUR HANDS CAREFULLY AFTER HANDLING OIL.
HAND THE OIL OVER TO OR HAVE IT COLLECTED BY THE NEAREST USED OIL RECYCLING COMPANY OR THE SUPPLIER.
DO NOT DISPOSE OF OIL IN THE ENVIRONMENT
KEEP OUT OF THE REACH OF CHILDREN**

Brake and clutch fluid

BRAKE AND CLUTCH FLUIDS CAN DAMAGE THE PLASTIC OR RUBBER PAINTED SURFACES. WHEN SERVICING THE BRAKING SYSTEM OR THE CLUTCH SYSTEM, PROTECT THESE COMPONENTS WITH A CLEAN CLOTH. ALWAYS WEAR PROTECTIVE GOGGLES WHEN SERVICING THESE SYSTEMS. BRAKE AND CLUTCH FLUIDS ARE EXTREMELY HARMFUL FOR YOUR EYES. IN THE EVENT OF ACCIDENTAL CONTACT WITH THE EYES, RINSE THEM IMMEDIATELY WITH ABUNDANT COLD, CLEAN WATER AND SEEK MEDICAL ADVICE. KEEP OUT OF THE REACH OF CHILDREN

Battery electrolyte and hydrogen gas**CAUTION**

THE BATTERY ELECTROLYTE IS TOXIC, CORROSIVE AND AS IT CONTAINS SULPHURIC ACID, IT CAN CAUSE BURNS WHEN IN CONTACT WITH THE SKIN. WHEN HANDLING BATTERY ELECTROLYTE, WEAR TIGHT-FITTING GLOVES AND PROTECTIVE APPAREL. IN THE EVENT OF SKIN CONTACT WITH THE ELECTROLYTIC FLUID, RINSE WELL WITH PLENTY OF CLEAN WATER. IT IS PARTICULARLY IMPORTANT TO PROTECT YOUR EYES BECAUSE EVEN TINY AMOUNTS OF BATTERY ACID MAY CAUSE BLINDNESS. IF THE FLUID GETS IN CONTACT WITH YOUR EYES, WASH WITH ABUNDANT WATER FOR FIFTEEN MINUTES AND CONSULT AN EYE SPECIALIST IMMEDIATELY. THE BATTERY RELEASES EXPLOSIVE GASES; KEEP IT AWAY FROM FLAMES, SPARKS, CIGARETTES OR ANY OTHER HEAT SOURCES. ENSURE ADEQUATE VENTILATION WHEN SERVICING OR RECHARGING THE BATTERY. KEEP OUT OF THE REACH OF CHILDREN BATTERY LIQUID IS CORROSIVE. DO NOT POUR IT OR SPILL IT, PARTICULARLY ON PLASTIC COMPONENTS. ENSURE THAT THE ELECTROLYTIC ACID IS COMPATIBLE WITH THE BATTERY TO BE ACTIVATED.

Maintenance rules**GENERAL PRECAUTIONS AND INFORMATION**

When repairing, dismantling and reassembling the vehicle follow the recommendations reported below carefully.

BEFORE REMOVING COMPONENTS

- Before dismantling components, remove dirt, mud, dust and foreign bodies from the vehicle. Use the special tools designed for this bike, as required.

COMPONENTS REMOVAL

- Do not loosen and/or tighten screws and nuts using pliers or any other tools than the specific wrench.
- Mark the positions on all connection joints (pipes, cables, etc.) before separating them, and identify them with different distinctive symbols.
- Each component needs to be clearly marked to enable identification during reassembly.
- Clean and wash the dismantled components carefully using a low-flammability detergent.
- Keep mated parts together since they have "adjusted" to each other due to normal wear.

- Some components must be used together or replaced altogether.
- Keep away from heat sources.

REASSEMBLY OF COMPONENTS

CAUTION

BEARINGS MUST BE ABLE TO ROTATE FREELY, WITHOUT JAMMING AND/OR NOISE: OTHERWISE, THEY NEED TO BE REPLACED.

- Only use ORIGINAL Moto Guzzi SPARE PARTS.
- Comply with lubricant and consumables use guidelines.
- Lubricate parts (whenever possible) before reassembling them.
- When tightening nuts and screws, start from the ones with the largest section or from the internal ones, moving diagonally. Tighten nuts and screws in successive steps before applying the tightening torque.
- Always replace self-locking nuts, washers, sealing rings, circlips, O-rings (OR), cotter pins and screws with new ones if their tread is damaged.
- When assembling the bearings, make sure to lubricate them well.
- Check that each component is assembled correctly.
- After a repair or routine maintenance procedure, carry out pre-ride checks and test the vehicle on private grounds or in an area with low traffic density.
- Clean all coupling surfaces, oil guard rims and gaskets before refitting them. Smear a light layer of lithium-based grease on the oil guard rims. Reassemble oil guards and bearings with the brand or lot number facing outward (visible side).

ELECTRIC CONNECTORS

Electric connectors must be disconnected as described below; failure to comply with this procedure causes irreparable damage to both the connector and the wiring harness:

Press the relevant safety hooks, if any.

- Grip the two connectors and disconnect them by pulling them in opposite directions.
- If any signs of dirt, rust, moisture, etc. are noted, clean the inside of the connector carefully with a jet of compressed air.
- Ensure that the cables are correctly fastened to the internal connector terminals.
- Then connect the two connectors, ensuring that they couple correctly (if fitted with clips, you will hear them "click" into place).

CAUTION

TO DISCONNECT THE TWO CONNECTORS, DO NOT PULL THE CABLES.

NOTE

THE TWO CONNECTORS CONNECT ONLY FROM ONE SIDE: CONNECT THEM THE RIGHT WAY ROUND.

TIGHTENING TORQUES

CAUTION

IF UNSCREWING A SELF-LOCKING NUT, IT MUST BE REPLACED WITH A NEW ONE.

CAUTION

DO NOT FORGET THAT THE TIGHTENING TORQUES OF ALL FASTENING ELEMENTS ON WHEELS, BRAKES, WHEEL BOLTS AND ANY OTHER SUSPENSION COMPONENTS PLAY A

KEY ROLE IN ENSURING VEHICLE SAFETY AND MUST COMPLY WITH SPECIFIED VALUES. CHECK THE TIGHTENING TORQUES OF FASTENING PARTS ON A REGULAR BASIS AND ALWAYS USE A TORQUE WRENCH TO REASSEMBLE THESE COMPONENTS. FAILURE TO COMPLY WITH THESE RECOMMENDATIONS MAY CAUSE ONE OF THESE COMPONENTS TO GET LOOSE AND EVEN DETACHED, THUS BLOCKING A WHEEL, OR OTHERWISE COMPROMISE VEHICLE HANDLING. THIS CAN LEAD TO FALLS, WITH THE RISK OF SERIOUS INJURY OR DEATH.

Running-in

Engine run-in is essential to ensure engine long life and correct operation. Twisty roads and gradients are ideal to run in engine, brakes and suspensions effectively. Vary your riding speed during the run-in. This ensures that components operate under both "loaded" and "unloaded" conditions, allowing the engine components to cool.

CAUTION

THE CLUTCH MAY EMIT A SLIGHT BURNING SMELL WHEN FIRST USED. THIS PHENOMENON SHOULD BE CONSIDERED NORMAL AND WILL DISAPPEAR AS SOON AS THE CLUTCH PLATES GET ADAPTED.

IT IS IMPORTANT TO STRAIN ENGINE COMPONENTS DURING RUN-IN, HOWEVER, MAKE SURE NOT TO OVERDO THIS.

CAUTION

THE FULL PERFORMANCE OF THE VEHICLE IS ONLY AVAILABLE AFTER THE SERVICE AT THE END OF THE RUNNING IN PERIOD.

Follow these guidelines:

- Do not twist the throttle grip abruptly and completely when the engine is working at a low revs, either during or after run-in.
- During the first 100 Km (62 miles) use the brakes gently, avoiding sudden or prolonged braking. That is to permit the adequate adjustment of the pad friction material to the brake discs.



AFTER THE SPECIFIED MILEAGE, TAKE THE VEHICLE TO AN OFFICIAL Moto Guzzi DEALER FOR THE CHECKS INDICATED IN THE "AFTER RUN-IN" TABLE IN THE SCHEDULED MAINTENANCE SECTION TO AVOID INJURING YOURSELF, OTHERS AND /OR DAMAGING THE VEHICLE.

Vehicle identification

SERIAL NUMBER LOCATION

These numbers are necessary for vehicle registration.

NOTE

ALTERING IDENTIFICATION NUMBERS MAY BE SERIOUSLY PUNISHABLE BY LAW. IN PARTICULAR, MODIFYING THE FRAME NUMBER IMMEDIATELY VOIDS THE WARRANTY.

This number consists of numbers and letters, as in the example shown below.

ZGULW10012MXXXXXX

KEY:

ZGU: WMI (World manufacturer identifier) code;

LW: model;

1/00 (V7 Stone), **2/00** (V7 Special), **3/00** (V7 Racer): versions;

0: free digit

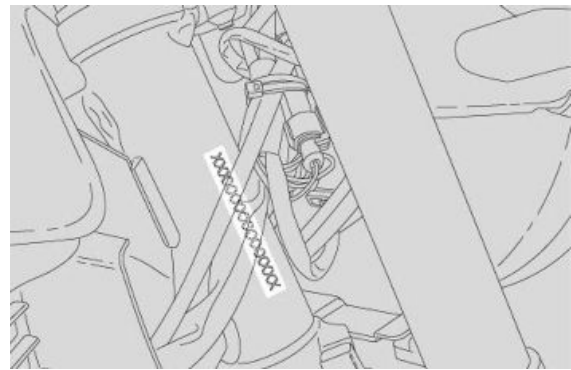
12: variable year of manufacture (12 - for 2012)

M: production plant (M= Mandello del Lario);

XXXXXX: serial number (6 digits);

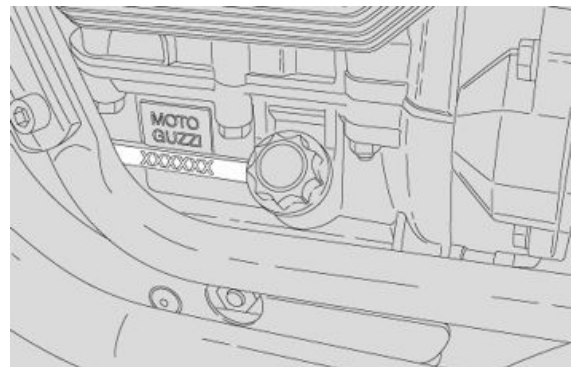
FRAME NUMBER

The chassis number is stamped on the right side of the headstock.



ENGINE NUMBER

The engine number is stamped on the left side, close to the engine oil level check cap.



Dimensions and mass

WEIGHT AND DIMENSIONS

Specification	Desc./Quantity
Max. length. (Roamer)	2240 mm (88.19 in)
Max. length. (Bobber)	2185 mm (86.02 in)
Max. width (Roamer)	865 mm (34.06 in)
Max. width (Bobber)	840 mm (33.07 in)
Max. height. (Roamer)	1165 mm (45.87 in)
Max. height. (Bobber)	1160 mm (45.67 in)
Wheelbase	1465 mm (57.68 in)
Saddle height (Roamer)	785 mm (30.91 in)
Saddle height (Bobber)	780 mm (30.71 in)
Kerb weight	210 Kg (462.97 lb)

Engine

ENGINE

Specification	Desc./Quantity
Type	traverse-mounted twin-cylinder four-stroke V 90°
Cylinder number	2
Engine capacity	853 cm ³ (52.05 cu.in)
Bore / stroke	84x77 mm (3.31x3.03 in)
Compression ratio	10.5 ± 0.5 : 1
Electric	Electric starter
Engine idle speed	1,250 +/- 100 rpm
Clutch	dry single-disc clutch with flexible coupling
Lubrication system	Pressure-fed, controlled by valves and trochoidal pump
Air filter	cartridge-type dry filter
Cooling	air

Transmission

TRANSMISSION

Specification	Desc./Quantity
Primary drive	with gears, ratio: 21 / 25 = 1 : 1.190
Gear ratios, 1st gear	16 / 39 = 1 : 2.437
Gear ratios, 2nd gear	18 / 32 = 1 : 1.777
Gear ratios, 3rd gear	21 / 28 = 1 : 1.333
Gear ratios, 4th gear	24 / 26 = 1 : 1.083
Gear ratios, 5th gear	25 / 24 = 1 : 0.96
Gear ratios, 6th gear	28 / 24 = 1 : 0.857
Final drive	with cardan shaft, ratio: 8 / 33 = 1 : 4.125

Capacities

CAPACITY

Specification	Desc./Quantity
Fuel tank (including reserve) V9 Roamer	15±0.5 l (3.30±0.11 UK gal; 3.96±0.13 US gal)
Fuel tank (including reserve) V9 Bobber	15±0.5 l (3.30±0.11 UK gal; 3.96±0.13 US gal)
Fuel tank reserve	4±0.5 l (0.88±0.11 UK gal; 1.06±0.13 US gal)
Engine oil	Oil change and oil filter replacement: 2000 cm ³ (122.05 cu.in)
Gearbox oil	500 cm ³ (30.51 cu.in)
Bevel gear set oil	210 cm ³ (12.81 cu.in)
Seats	2
Maximum carrying load	420 kg (925.94 lb) (rider + passenger + luggage)

Electrical system

ELECTRICAL SYSTEM

Specification	Desc./Quantity
Battery	12 V - 12 Ah
Fuses	30 - 5 (2) - 15 (3) - 20 (2) A
Permanent magnet alternator	12V - 270W

SPARK PLUGS

Specification	Desc./Quantity
Standard	NGK CPR8EB-9
Spark plug electrode gap	0.6 - 0.7 mm (0.024 - 0.027 in)
Resistance	5 kOhm

BULBS

Specification	Desc./Quantity
Low/high beam light (halogen)	12 V - 55 W / 60 W H4
Front daylight running lights	12V - 5W
Turn indicator light	12 V - 10 W (orange RY 10 W bulb)
tail light /stop lights	12 V - 5 / 21 W
Dashboard lighting	LED

WARNING LIGHTS

Specification	Desc./Quantity
Gear in neutral	LED
Turn indicators	LED
Fuel reserve	LED
High beam light	LED
General alarm	LED
MI warning light	LED
ABS Warning Light	LED
MGCT warning light	LED

Frame and suspensions

FRAME

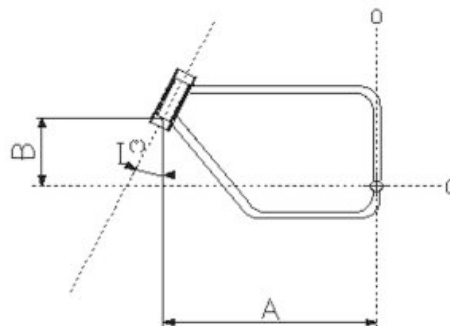
Specification	Desc./Quantity
Type	Modular double cradle, high strength steel tubular chassis
Steering rake	26°
Trail	117 mm (4.61 in)

SUSPENSIONS

Specification	Desc./Quantity
Front	hydraulic telescopic fork, Ø 40 mm (1.57 in)
Travel	130 mm (5.12 in)
Rear - V7 Special / V7 Stone	Swingarm in die-cast light alloy, 2 shock absorbers with adjustable spring preloading
Rear - V7 Racer	die-cast light alloy swingarm with 2 adjustable shock absorbers
Wheel travel	100 mm (3.93 in)

SIZES A AND B

Specification	Desc./Quantity
Size A	692 mm (27.24 in)
Size B	186 mm (7.32 in)



Brakes

BRAKES

Specification	Desc./Quantity
Front	stainless steel floating disc, Ø 320 mm (12.59 in), callipers with 4 different and counteracting plungers
Rear	260 mm (10.24 in) stainless steel disc, floating calliper with two 22 mm (0.87 in) diameter pistons

Wheels and tyres

WHEEL RIMS

Specification	Desc./Quantity
Type	Alloy wheels for tubeless tyres
Front (Roamer)	2.5" x 19"
Front (Bobber)	3.5" x 16"
Rear	4.0" x 16"

TYRES

Specification	Desc./Quantity
Tyre type (Roamer)	Pirelli Sport Demon
Tyre type (Bobber)	(Front) Continental Conti Milestone CM1 (Rear) Continental Conti Milestone CM2
Front (Roamer)	100 / 90 - 19 57V
Front (Bobber)	130 / 90 - 16 67H
Front tyre inflation pressure (Roamer)	2.3 bar (230 kPa) (33.36 PSI)
Front tyre inflation pressure (Bobber)	2.5 bar (250 kPa) (36.26 PSI)
Front tyre inflation pressure with passenger (Roamer)	2.4 bar (240 kPa) (34.81 PSI)
Front tyre inflation pressure with passenger (Bobber)	2.6 bar (260 kPa) (37.71 PSI)
Rear (Roamer)	150 / 80 - V16 71V
Rear (Bobber)	150 / 80 - B16 77H
Rear tyre inflation pressure (Roamer)	2.5 bar (250 kPa) (36.26 PSI)
Rear tyre inflation pressure (Bobber)	2.8 bar (280 Kpa) (40.61 PSI)
Rear tyre inflation pressure with passenger (Roamer)	2.6 bar (260 kPa) (37.71 PSI)
Rear tyre inflation pressure with passenger (Bobber)	2.9 bar (290 Kpa) (42.06 PSI)

Supply

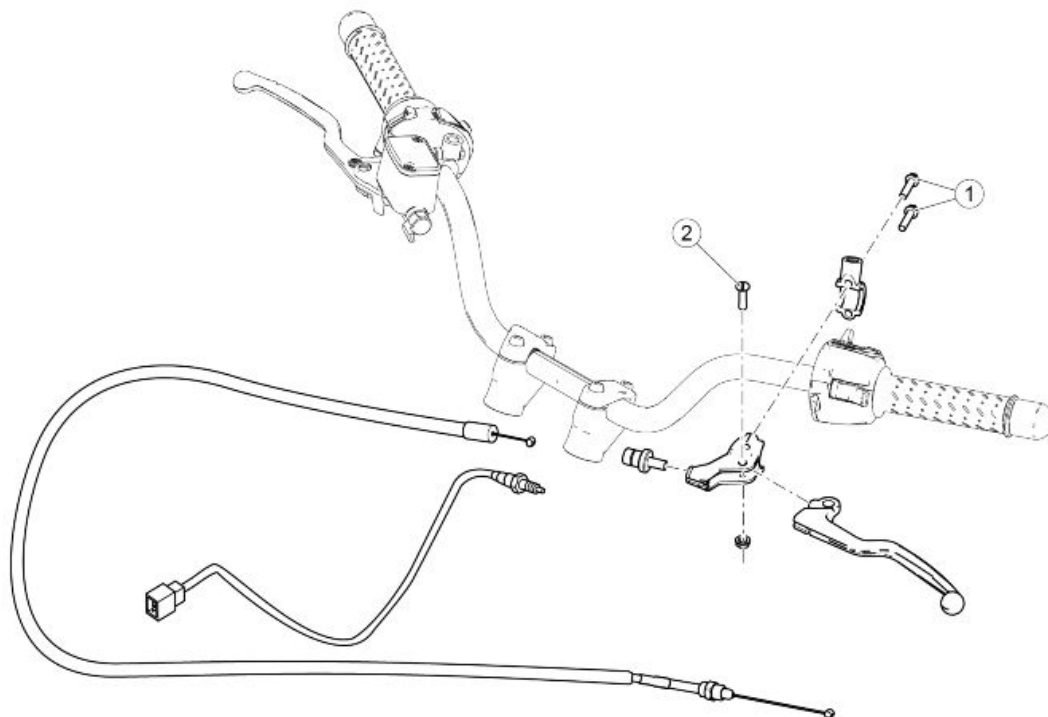
FUEL SYSTEM

Specification	Desc./Quantity
Type	Electronic injection (Marelli MIU G3)
Diffuser	Ø 38 mm (1.50 in)
Fuel	Premium unleaded petrol, minimum octane rating of 95 (NORM) and 85 (NOMM)

Tightening Torques

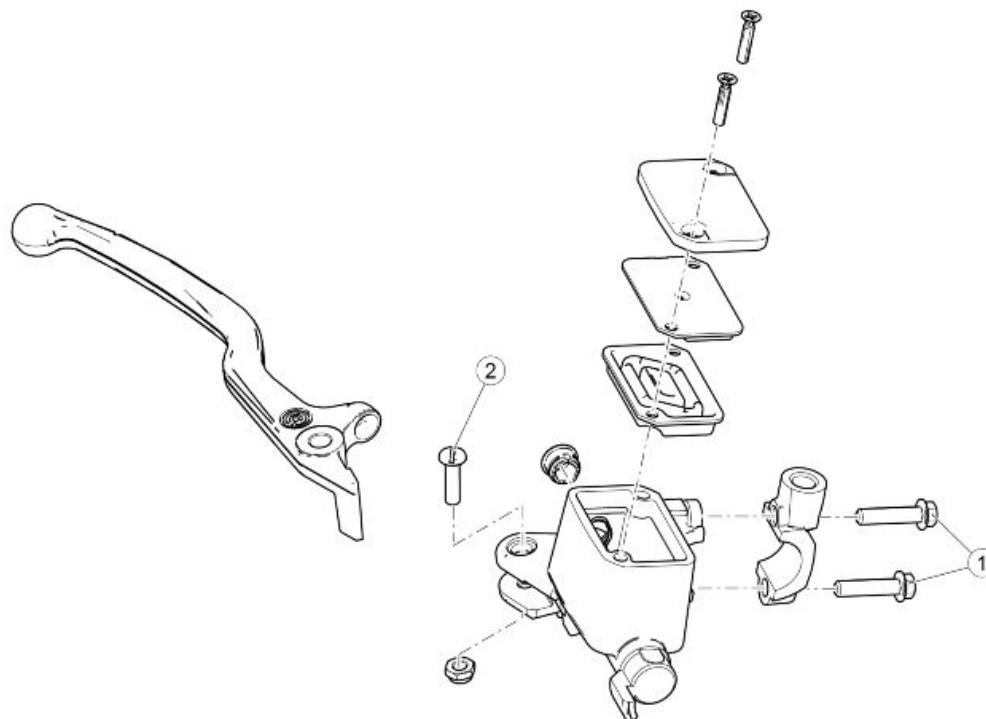
Chassis

Front side



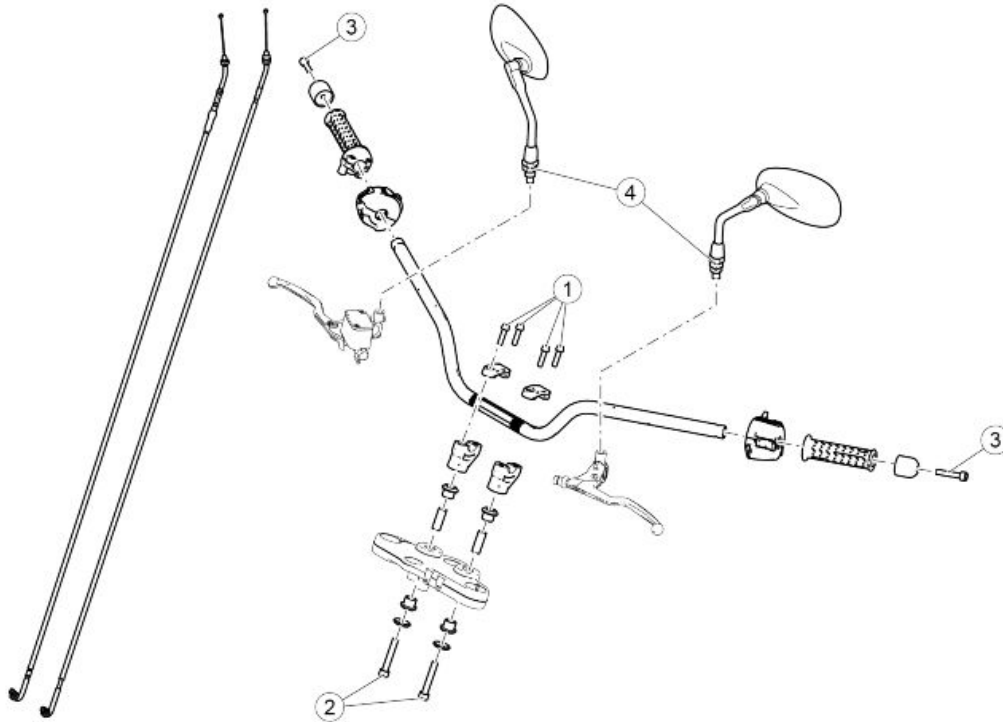
CLUTCH CONTROL

pos.	Description	Type	Quantity	Torque	Notes
1	Throttle control U-bolt fixing screws	M6x25	2	10 Nm (7.38 lb ft)	-
2	Clutch control pin	M6	1	10 Nm (7.38 lb ft)	-



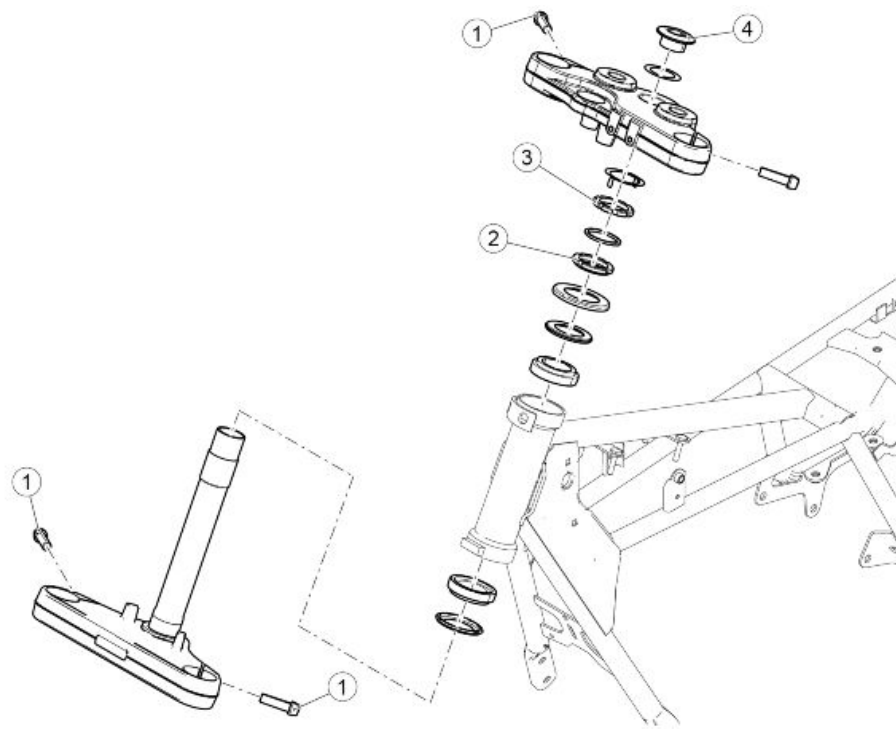
FRONT BRAKE PUMP

pos.	Description	Type	Quantity	Torque	Notes
1	Brake pump U-bolt fixing screws	M6x25	2	10 Nm (7.38 lb ft)	-
2	Brake pump control pin	M6	1	10 Nm (7.38 lb ft)	-



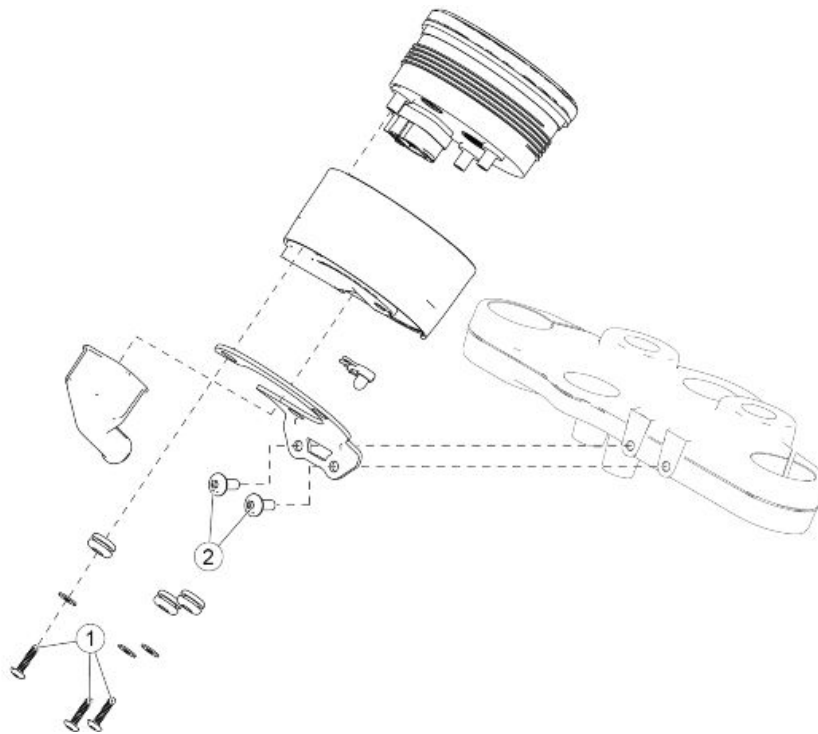
HANDLEBAR

pos.	Description	Type	Quantity	Torque	Notes
1	Handlebar U-bolt fastener screw	M8	4	25 Nm (18.44 lb ft)	-
2	Handlebar U-bolt mountings fastener screw	M10x60	2	50 Nm (36.88 lb ft)	Loct. 243
3	Handlebar counterweight fastener SHC screws	M6x35	2	10 Nm (7.38 lb ft)	-
4	Rear-view mirrors	M10	2	Manual	-



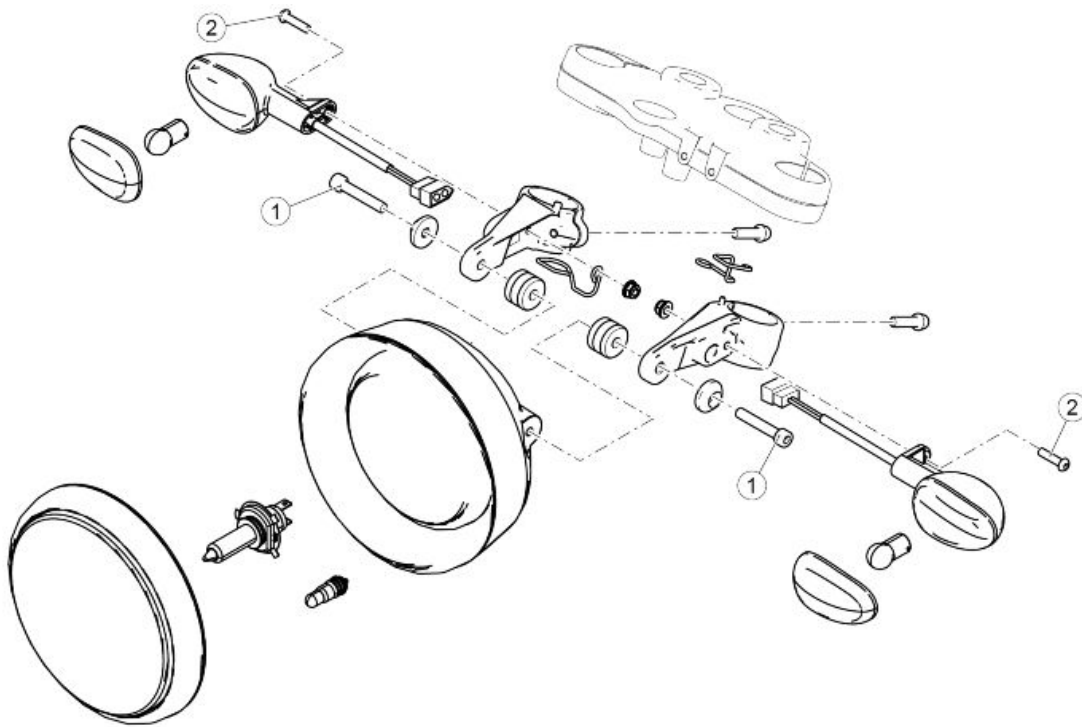
STEERING

pos.	Description	Type	Quantity	Torque	Notes
1	Screw fixing stanchions to upper and lower plate	M10x40	4	25 Nm (18.44 lb ft)	-
2	Steering headstock ring nut (pre-tightening)	-	1	60 Nm (44.25 lb ft)	-
2	Steering headstock ring nut (tightening)	-	1	50 +/- 5 Nm (36.88 +/- 3.69 lb ft)	-
3	Headstock counter ring nut	-	1	-	Screw until obtaining contact with the rubber washer
4	Headstock bushing	-	1	100 Nm (73.76 lb ft)	-



INSTRUMENT PANEL

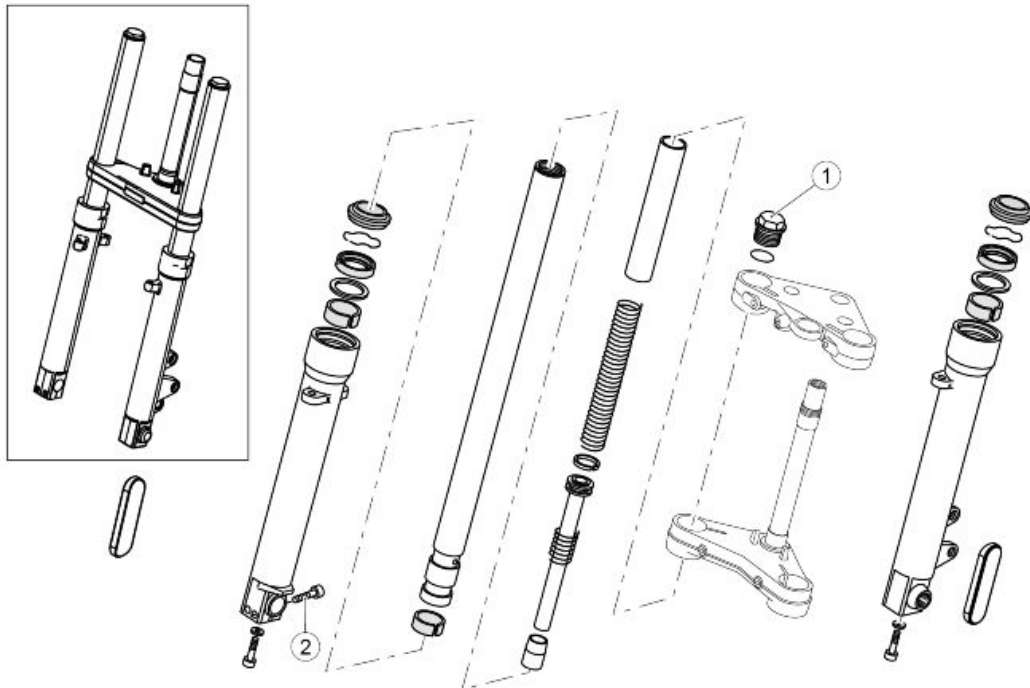
pos.	Description	Type	Quantity	Torque	Notes
1	Instrument panel support bracket fixing screws	-	3	1.5 Nm (1.11 lb ft)	-
2	Screw fixing the support bracket to the steering plate	M6x10	2	10 Nm (7.38 lb ft)	-



FRONT LIGHTS

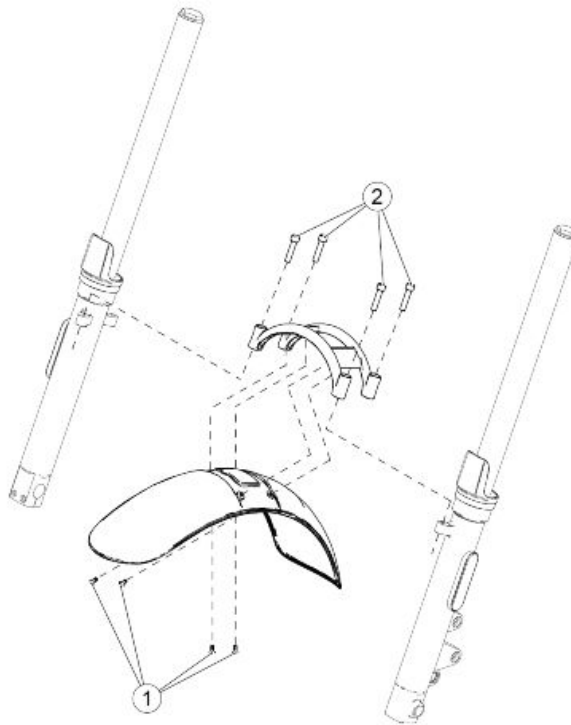
pos.	Description	Type	Quantity	Torque	Notes
1	Headlamp fastening screws	M8x45	2	15 Nm (11.06 lb ft)	-

pos.	Description	Type	Quantity	Torque	Notes
2	Front turn indicators SHC fastening screws	M6x25	2	10 Nm (7.38 lb ft)	-



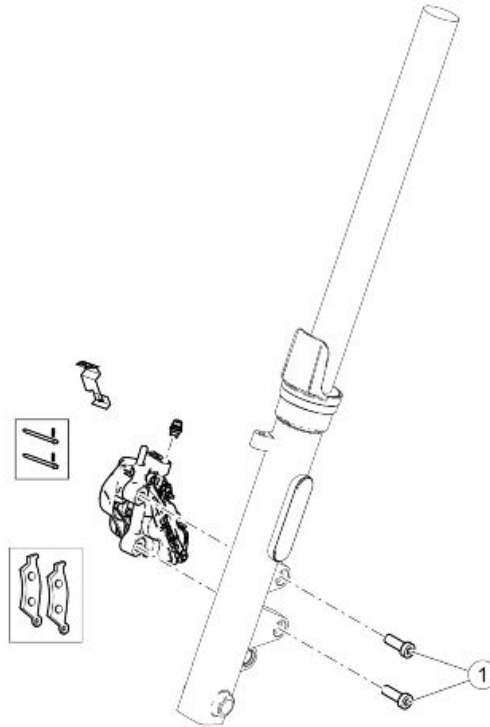
FORK

pos.	Description	Type	Quantity	Torque	Notes
1	Stanchion cap	-	2	50 Nm (36.88 lb ft)	-
2	Screw fixing wheel axle to right fork leg	M6x30	1	10 Nm (7.38 lb ft)	-
-	Screws fastening stanchions to the lower plate	M10x40	2	25 Nm (18.44 lb ft)	-



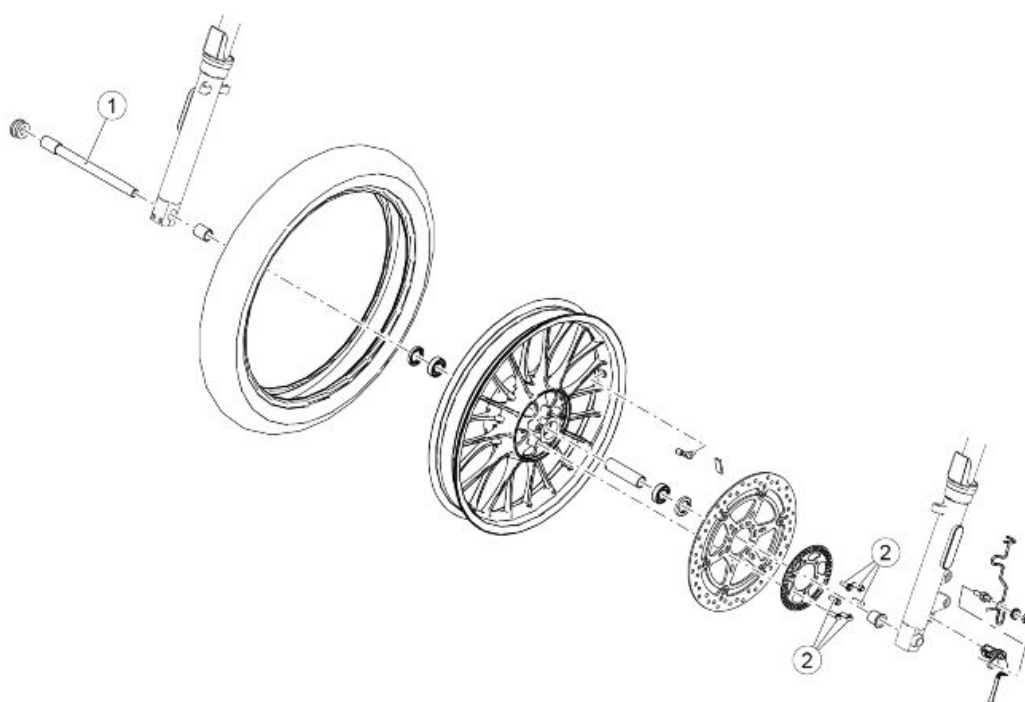
FRONT MUDGUARD

pos.	Description	Type	Quantity	Torque	Notes
1	Screws fastening the mudguard to the stabiliser plate	M5x10	4	4 Nm (2.95 lb ft)	Loct. 243
2	Screws fastening the stabiliser plate to the fork sleeves	M8x45	4	15 Nm (11.06 lb ft)	Loct. 243



FRONT BRAKE CALLIPER

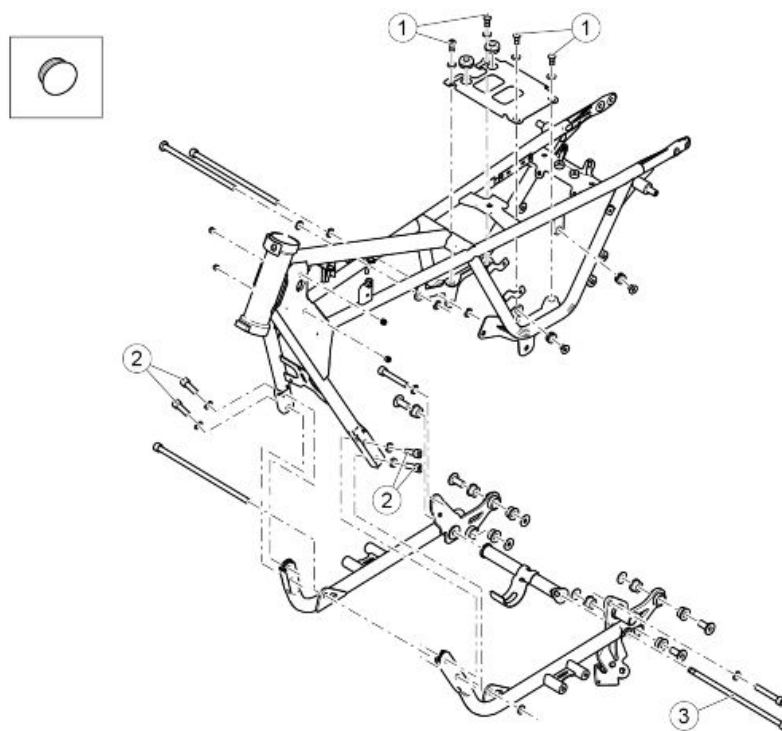
pos.	Description	Type	Quantity	Torque	Notes
1	Brake calliper fixing screws	M10x30	2	50 Nm (36.88 lb ft)	-



FRONT WHEEL

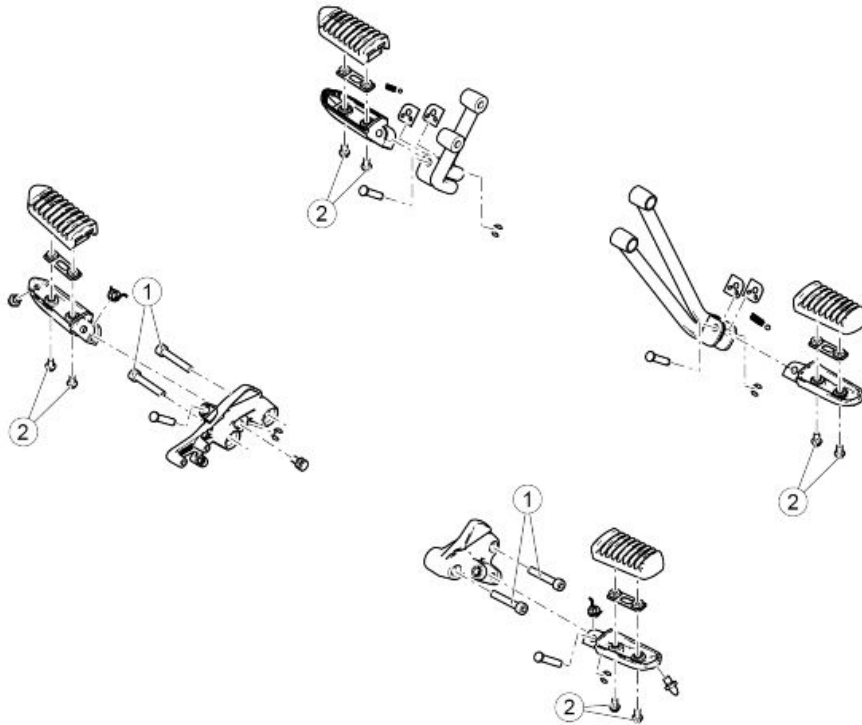
pos.	Description	Type	Quantity	Torque	Notes
1	Front wheel axle	M18	1	80 Nm (59.00 lb ft)	-
2	Phonic wheel/brake disc fastening screws	M8x18	6	25 Nm (18.44 lb ft)	Loct. 243

Central part



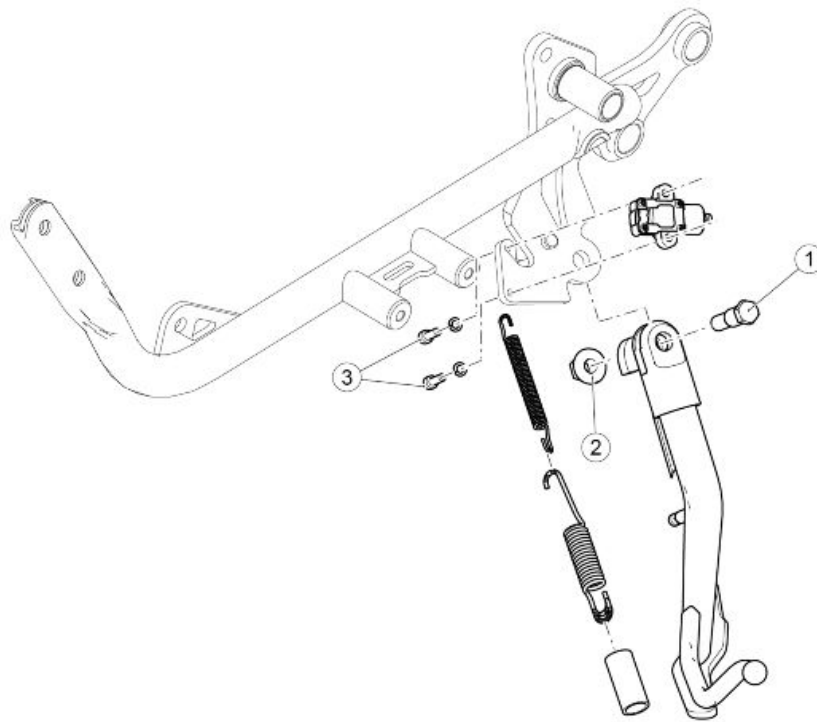
CHASSIS

pos.	Description	Type	Quantity	Torque	Notes
1	Battery holder plate fastening screws	M8x20	4	25 Nm (18.44 lb ft)	-
2	Front cradle SHC fixing screws	M10x30	4	50 Nm (36.88 lb ft)	-
3	Pin fastening the stand to the cradles	M10x266	1	50 Nm (36.88 lb ft)	-



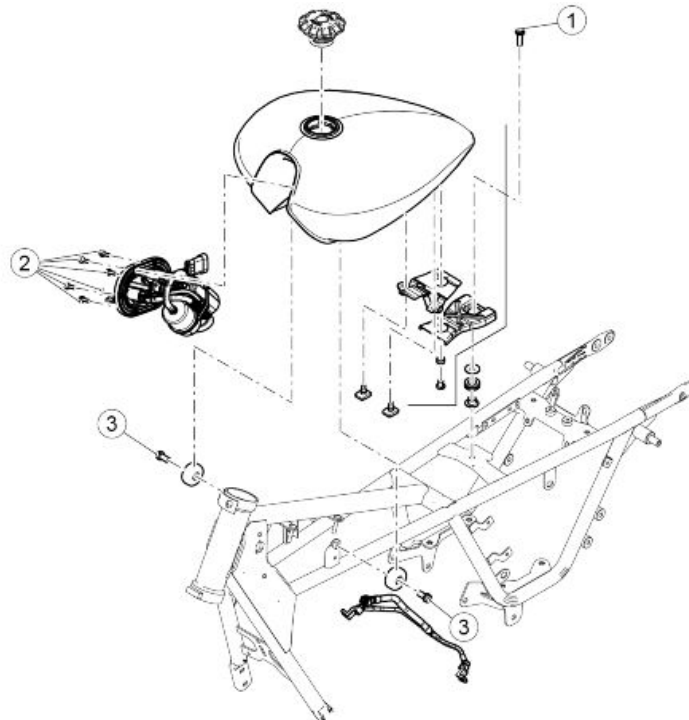
FOOTRESTS

pos.	Description	Type	Quantity	Torque	Notes
1	SHC screws fastening the rider footrest mounting	M8x45	4	25 Nm (18.44 lb ft)	Loct. 243
2	Flanged hexagon screws fastening the footrest rubber guards	M6x12	8	10 Nm (7.38 lb ft)	-
-	Passenger footrest support fastening screws	M8x30	4	25 Nm (18.44 lb ft)	-



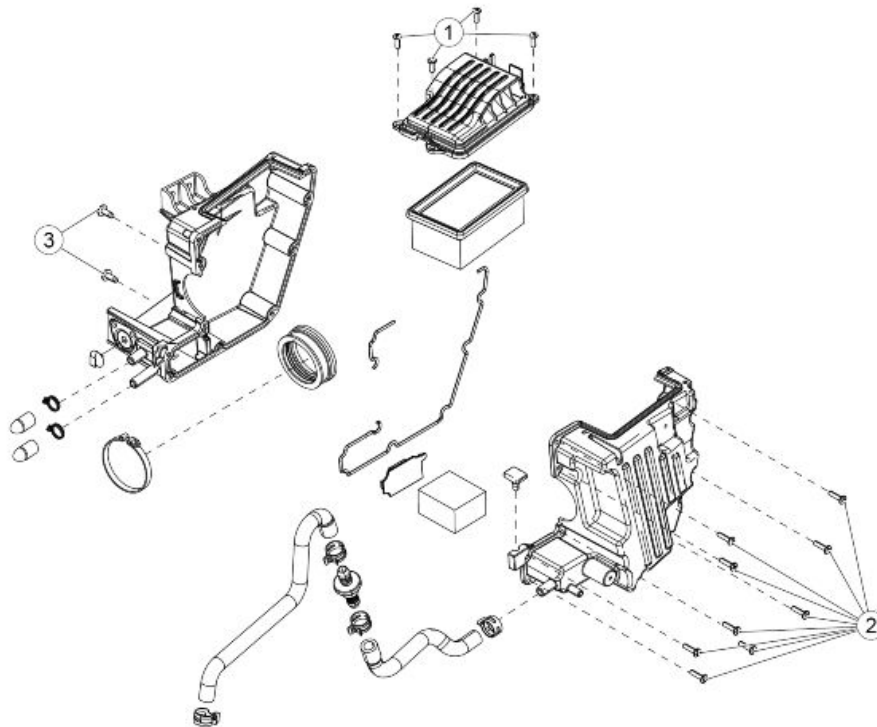
SIDE STAND

pos.	Description	Type	Quantity	Torque	Notes
1	Side stand retainer pin	M10x1.2 5	1	10 Nm (7.38 lb ft)	-
2	Lock nut for side stand bolt	M10x1.2 5	1	30 Nm (22.13 lb ft)	-
3	SHC screws fastening the switch	M5x16	2	6 Nm (4.43 lb ft)	Loct. 243



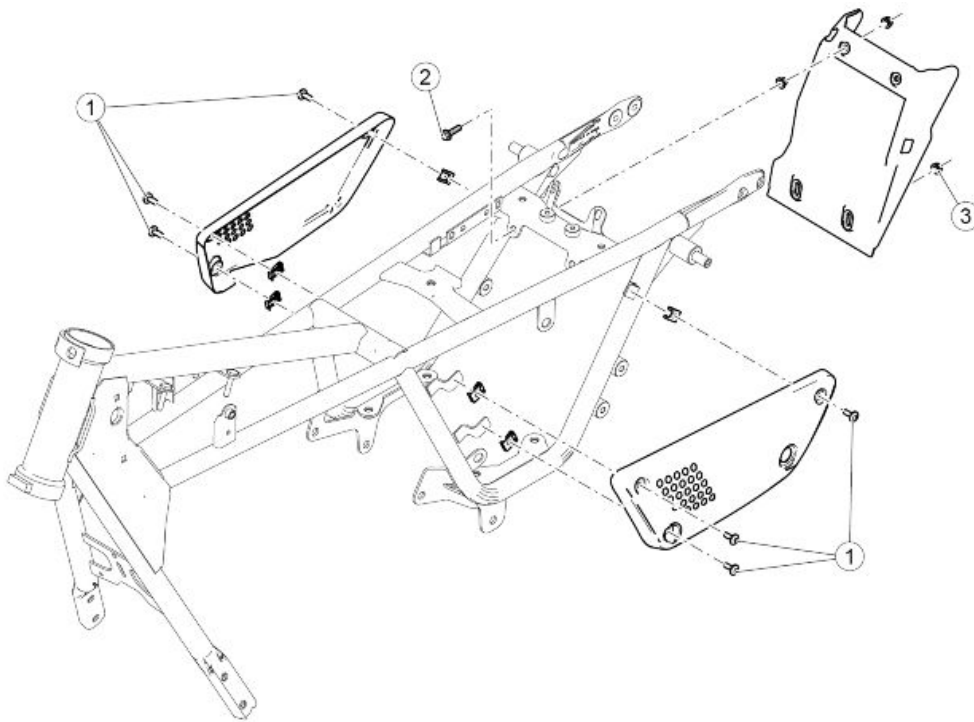
FUEL TANK

pos.	Description	Type	Quantity	Torque	Notes
1	Tank rear fastening hexagon screw	M8	1	25 Nm (18.44 lb ft)	-
2	Fuel pump fastening hexagon screws	M5x16	6	5 Nm (3.69 lb ft)	-
3	SHC screws fastening the tank support buffers	M8x16	2	25 Nm (18.44 lb ft)	-



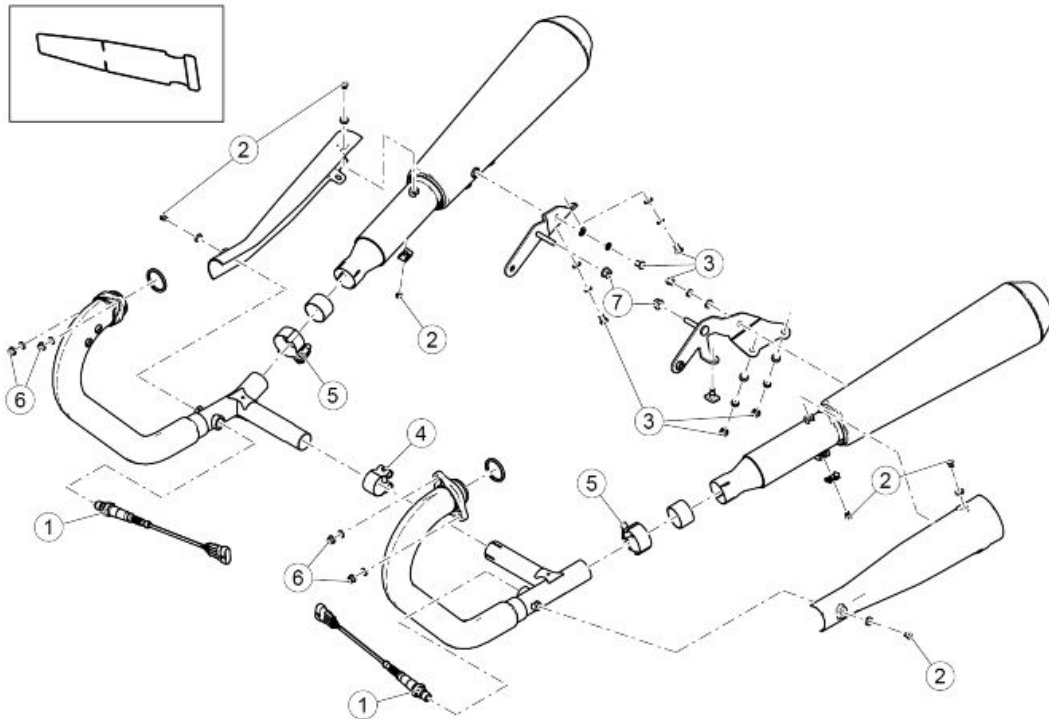
FILTER BOX

pos.	Description	Type	Quantity	Torque	Notes
1	Air filter box cover fastening self-threading screw	M5x14	4	3 Nm (2.21 lb ft)	-
2	SWP screws fixing filter box to chassis	M5x20	2	3 Nm (2.21 lb ft)	-
3	SWP filter box locking screws	M5x20	9	3 Nm (2.21 lb ft)	-



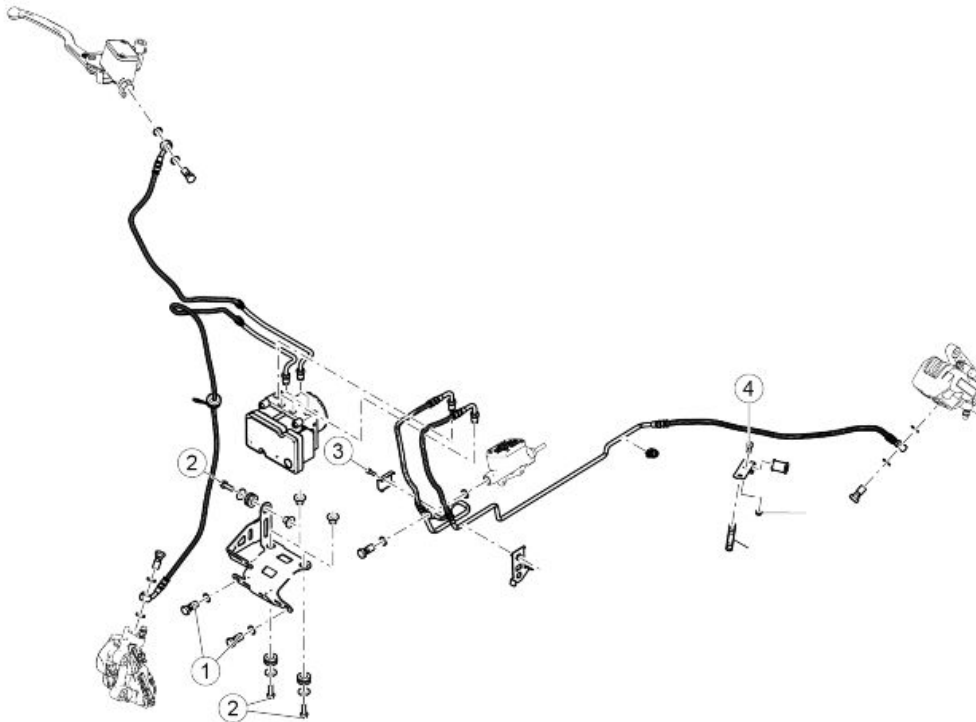
CENTRAL BODYWORK

Pos.	Description	Type	Quantity	Torque	Notes
1	TBEI screws fastening fearing	M5x15	6	4 Nm (2.95 lb ft)	-
2	TE flanged screws fastening top splash guard	M6	2	10 Nm (7.38 lb ft)	-
3	Flanged nuts fastening bottom splash guard	M6	2	10 Nm (7.38 lb ft)	-



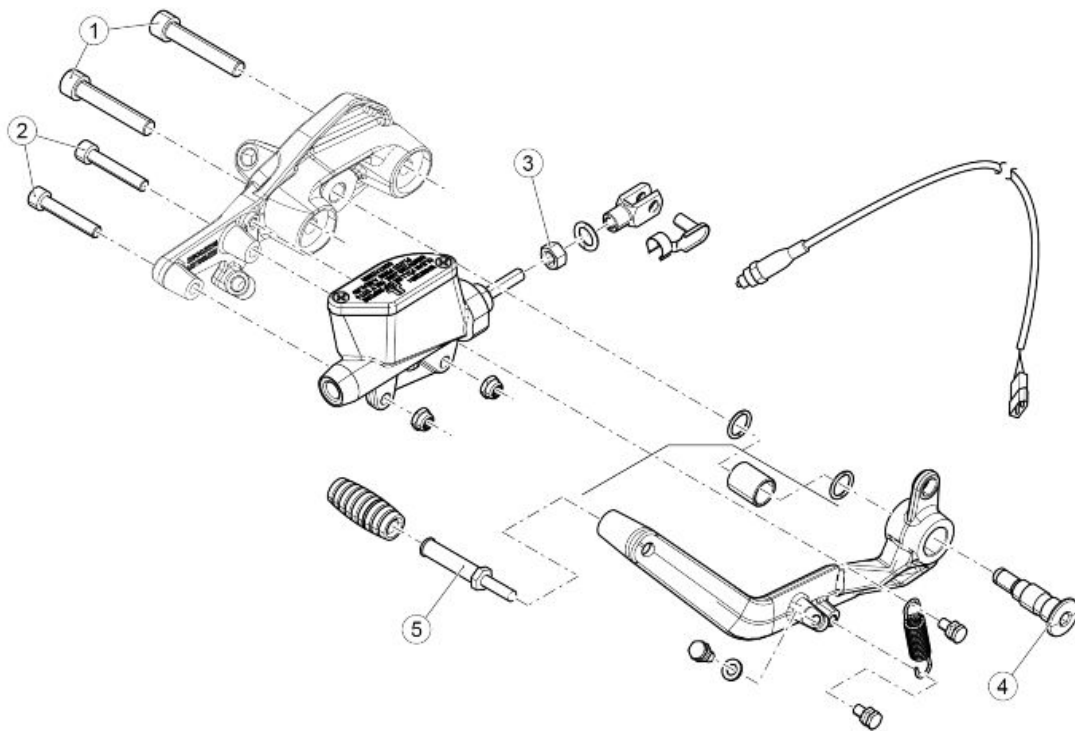
EXHAUST SYSTEM

pos.	Description	Type	Quantity	Torque	Notes
1	Lambda probes fastener	M18x1.5	2	38 Nm (28.03 lb ft)	-
2	Flanged TBEI screws fixing exhausts protections	M6x10	6	8 Nm (5.90 lb ft)	-
3	TBEI screws fixing mufflers to the supports	M8x12	6	25 Nm (18.44 lb ft)	-
4	Fixing exhaust pipes to the compensator	M8	1	25 Nm (18.44 lb ft)	-
5	Fixing exhaust pipes to the mufflers	M10	2	30 Nm (22.13 lb ft)	-
6	Flanged nuts fastening to the engine exhaust pipes	M8	4	25 Nm (18.44 lb ft)	-
7	Nuts fastening mufflers' support to the frame	M8x1.25	4	25 Nm (18.44 lb ft)	-



ABS SYSTEM

pos.	Description	Type	Quantity	Torque	Notes
1	Control unit bracket fastening to the frame	M6x16	2	10 Nm (7.38 lb ft)	-
2	Screws fastening the ABS modulator to the support	M6x20	3	10 Nm (7.38 lb ft)	-
3	SHC screw fastening the brake pipes fixing plate	M4x16	1	3 Nm (2.21 lb ft)	-
4	SHC screw fastening the cable grommet plate	M5x12	1	6 Nm (4.43 lb ft)	-

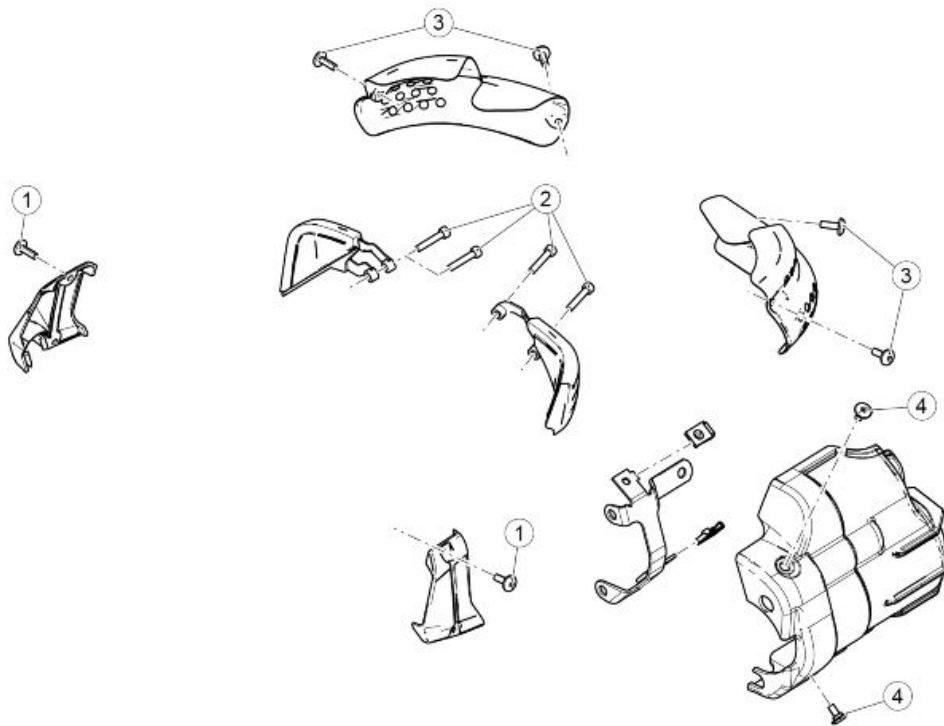


REAR BRAKE PUMP

pos.	Description	Type	Quantity	Torque	Notes
1	SHC screws fastening the gearbox support plate to the chassis	M10x55	2	55 Nm (40.57 lb ft)	-
2	SHC screws fastening the brake pump to the gearbox support plate	M6x25	2	10 Nm (7.38 lb ft)	-
3	Rear brake rod lock nut	M6	1	10 Nm (7.38 lb ft)	-
4	Brake lever pin	M8	1	20 Nm (14.75 lb ft)	-
5	Rear brake pedal	M8	1	25 Nm (18.44 lb ft)	-

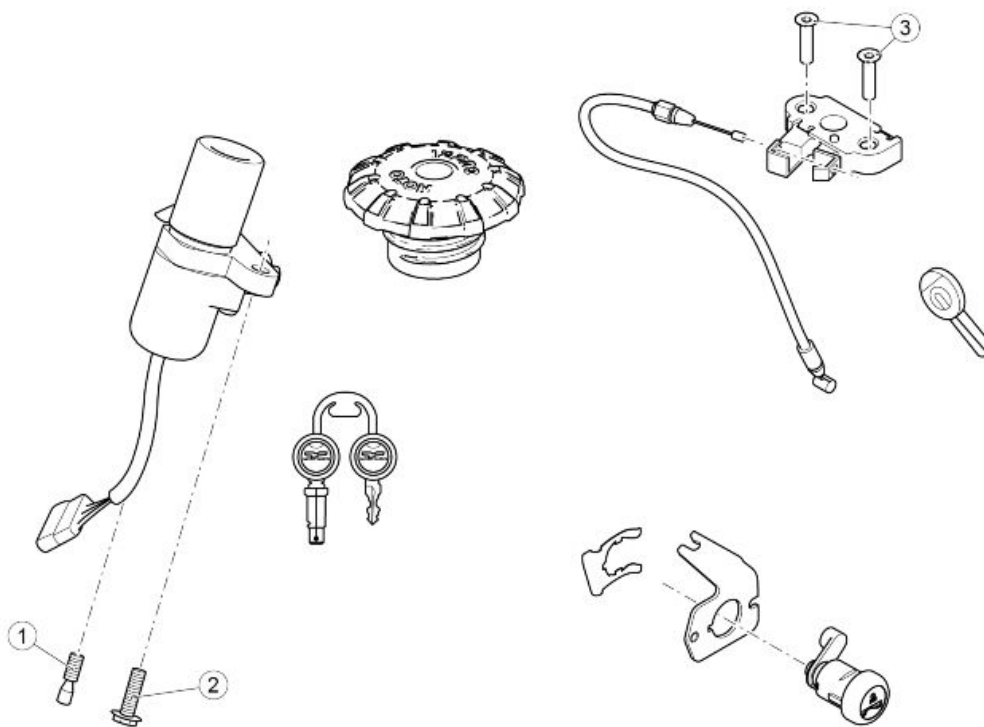
GEAR LEVER

pos.	Description	Type	Quantity	Torque	Notes
1	Gearbox lever pin	M8	1	20 Nm (14.75 lb ft)	-
2	Gearbox pedal	M8	1	25 Nm (18.44 lb ft)	-
3	SHC screws fixing the gearbox control lever	M6x16	2	10 Nm (7.38 lb ft)	-
4	Nuts fastening the gearbox control tie rods	M6	4	10 Nm (7.38 lb ft)	-



GUARDS

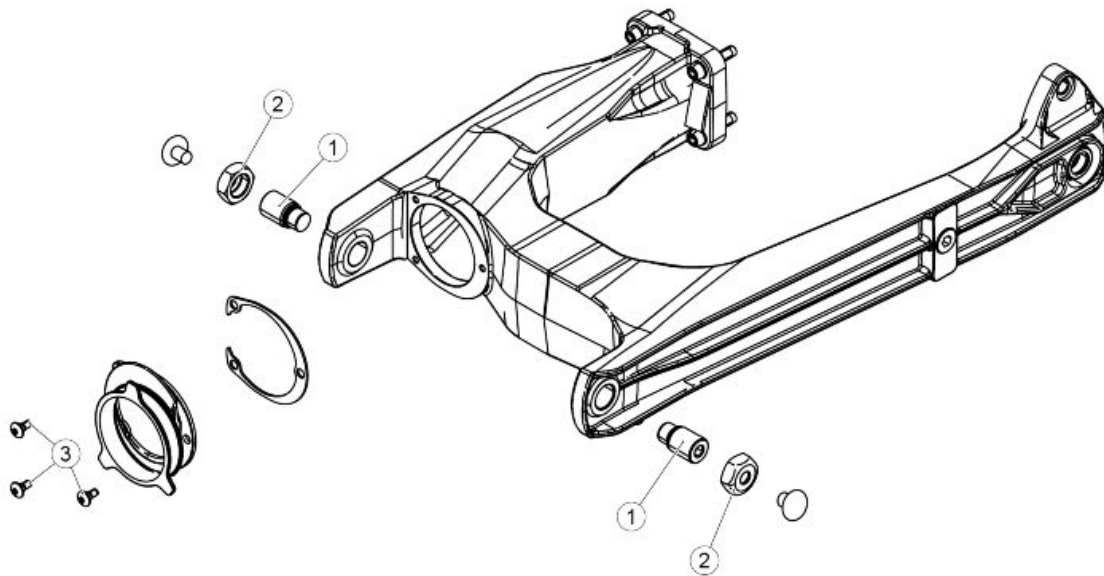
pos.	Description	Type	Quantity	Torque	Notes
1	SWP screws fastening the frame cover	-	4	3 Nm (2.21 lb ft)	-
2	SHC screws fastening the head cover	M6x30	4	10 Nm (7.38 lb ft)	-
3	Throttle body cover fastening screws	M5x15	4	4 Nm (2.95 lb ft)	-
4	TBEI screws fastening the starter motor cover	M5x9	2	4 Nm (2.95 lb ft)	-



LOCKS

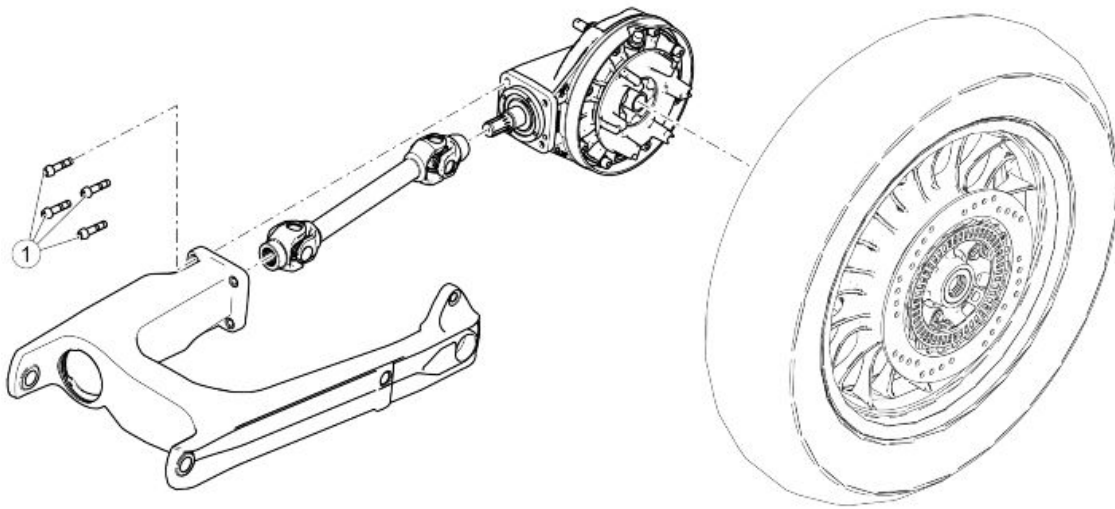
pos.	Description	Type	Quantity	Torque	Notes
1	Special screw fastening the ignition lock	M8x15	1	At the point of failure	-
2	Ignition lock fixing screw	M8x15	1	25 Nm (18.44 lb ft)	-
3	Saddle release block fixing screws	M8x25	2	10 Nm (7.38 lb ft)	-

Back side



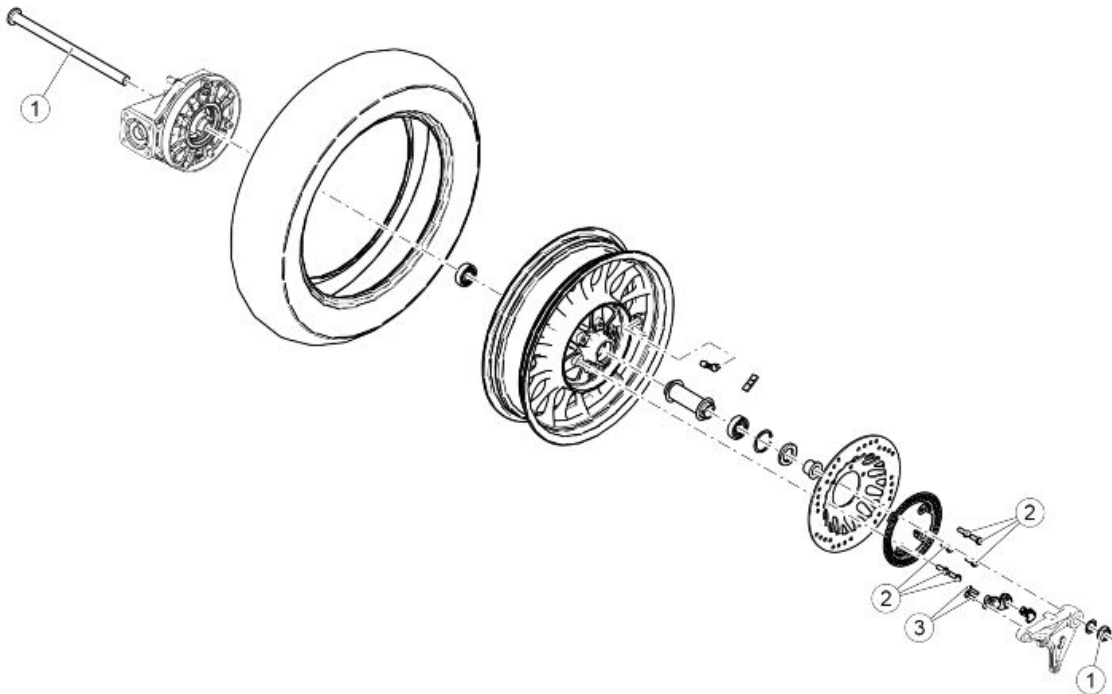
SWINGARM

pos.	Description	Type	Quantity	Torque	Notes
1	Pins fixing swingarm to gearbox	-	2	-	Manual
2	Locknuts fixing swingarm to gearbox	-	2	50 Nm (36.88 lb ft)	-
3	Torx screws fastening rubber bellows	-	3	6 Nm (4.43 lb ft)	-



REAR TRANSMISSION

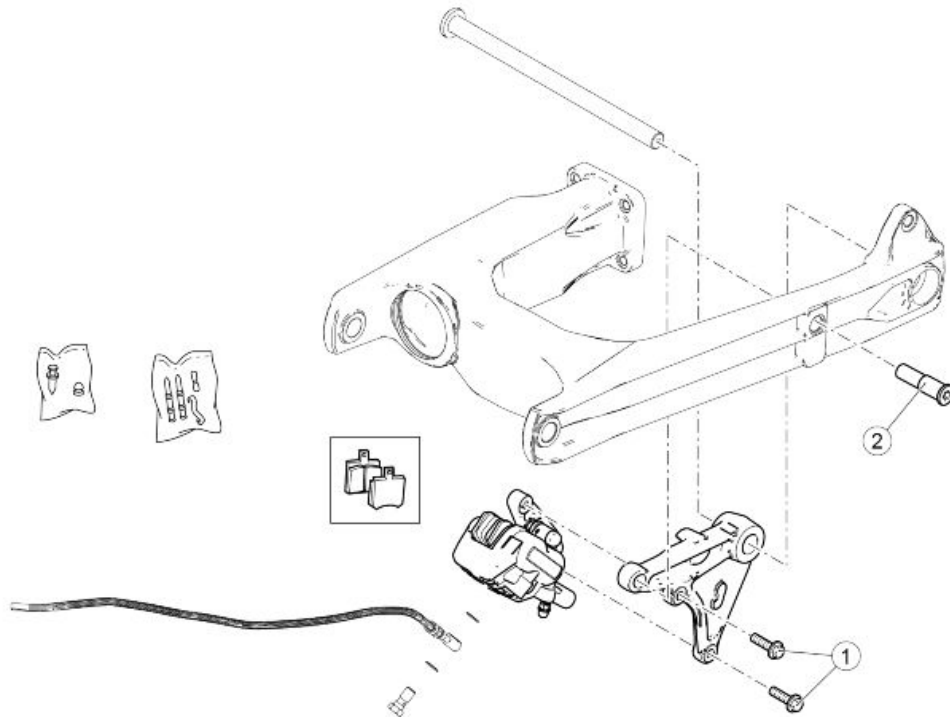
pos.	Description	Type	Quantity	Torque	Notes
1	Swingarm torx SHC fixing screws on the transmission housing	M8x35	4	25 Nm (18.44 lb ft)	-



REAR WHEEL

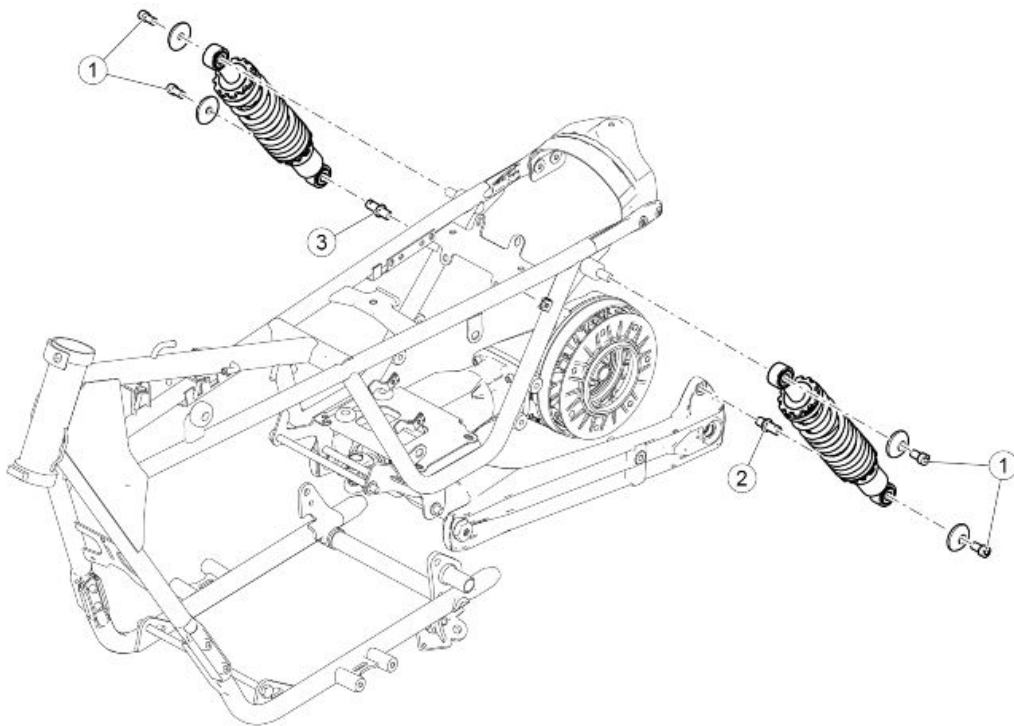
pos.	Description	Type	Quantity	Torque	Notes
1	Rear wheel axle fixing nut	M20	1	120 Nm (88.51 lb ft)	-

pos.	Description	Type	Quantity	Torque	Notes
2	Flanges TE screws fastening phonic wheel and brake disc	M8x22	6	25 Nm (18.44 lb ft)	Loct. 243
3	SHC screws fastening ABS sensor support	M6x12	2	10 Nm (7.38 lb ft)	-



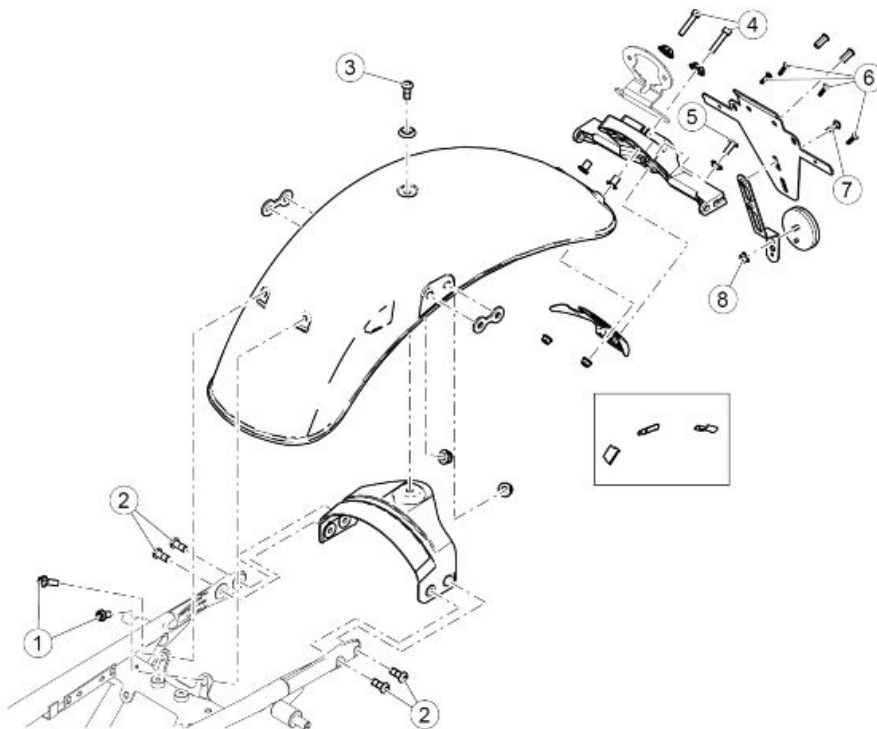
REAR BRAKE CALLIPER

pos.	Description	Type	Quantity	Torque	Notes
1	Flanged TE screws fixing rear brake calliper	M8x30	2	25 Nm (18.44 lb ft)	-
2	Rear brake calliper support pin	M16	1	35 Nm (25.81 lb ft)	-



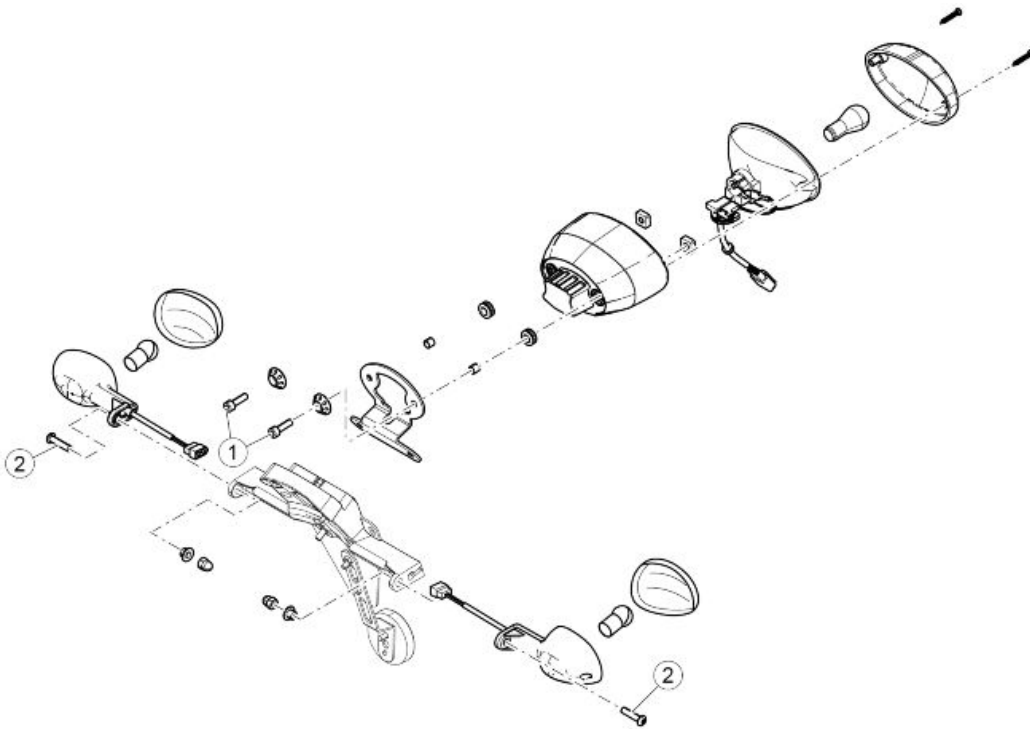
SHOCK ABSORBERS

pos.	Description	Type	Quantity	Torque	Notes
1	Top shock absorber SHC fixing screws	M6x18	2	10 Nm (7.38 lb ft)	-
2	Pin for fastening the shock absorber to chassis	M12	1	35 Nm (25.81 lb ft)	Loct. 243
3	Pin for fastening the shock absorber to gearbox	M12	1	35 Nm (25.81 lb ft)	Loct. 243



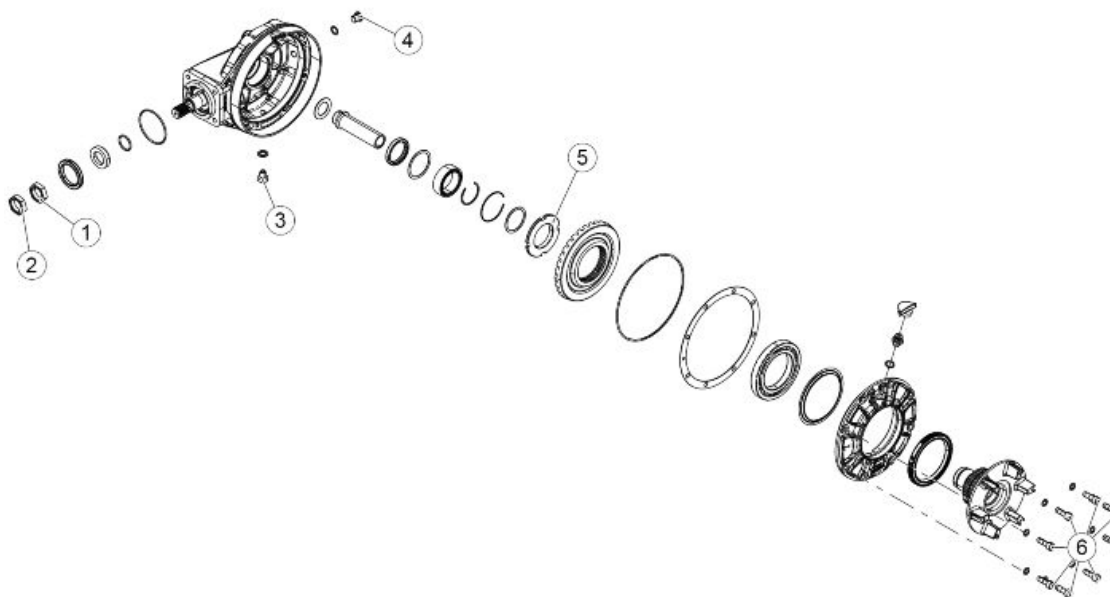
REAR MUDGUARD

pos.	Description	Type	Quantity	Torque	Notes
1	Flanged screw fixing front mudguard to chassis	M6	2	10 Nm (7.38 lb ft)	-
2	Mudguard side fixing screws to chassis	M8x20	4	35 Nm (25.81 lb ft)	-
3	Big end rounded torx screw fastening top mudguard to chassis	M8x20	1	15 Nm (11.06 lb ft)	-
4	SHC screws fastening the license plate and headlight support to the mudguard	M6x30	2	10 Nm (7.37 lb ft)	-
5	Flanged TBEI screws fixing licence plate holder to frame	M6x16	1	10 Nm (7.37 lb ft)	-
6	Licence plate cover self-threading fixing screws	-	4	3 Nm (2.21 lb ft)	-
7	Flanged TBEI screw fastening reflector support	M5x16	1	6 Nm (4.43 lb ft)	-
8	Flanged self-locking nut fastening reflector	M5	1	6 Nm (4.43 lb ft)	-



REAR LIGHTS

pos.	Description	Type	Quantity	Torque	Notes
1	SHC taillight fixing screws	M6x20	1	10 Nm (7.38 lb ft)	-
2	TBEI screws fastening rear turn indicators	M6x25	2	10 Nm (7.38 lb ft)	-



BEVEL GEAR

pos.	Description	Type	Quantity	Torque	Notes
1	Pinion unit retainer nut	M25x1.25	1	100 Nm (73.76 lb ft)	Loct. 243
2	Pinion unit retainer locknut	M25x1.25	1	20 Nm (14.75 lb ft)	Loct. 243
3	Oil drainage plug	M10x1.5	1	30 Nm (22.13 lb ft)	-
4	Oil load cap	M12x1.5	1	25 Nm (18.44 lb ft)	-
5	Crown sprocket fixing ring nut	-	1	100 Nm (73.76 lb ft)	Loct. 243
6	Crown fixing torx screws	M8x25	8	25 Nm (18.44 lb ft)	-

Recommended products chart

Piaggio & C. S.p.A. prescribes eni products for the scheduled maintenance of its vehicles



RECOMMENDED PRODUCTS TABLE

Product	Description	Specifications
ENI i-RIDE PG 10W-60	Lubricant formulated with advanced synthetic technology and high performance additives to cater specifically for 4-stroke engines with high specific power outputs.	JASO MA, MA2 - API SG
AGIP GEAR MG SAE 85W-140	Transmission oil	API GL-4 and GL-5
ENI ROTRA LSX 75W-90	Gearbox oil	API GL-5
AGIP FORK 7.5W	Fork oil	SAE 5W / SAE 20W

Product	Description	Specifications
AGIP GREASE SM 2	Gray black smooth-textured lithium grease, containing molybdenum disulphide.	-
Neutral grease or petroleum jelly.	Battery poles	
AGIP BRAKE 4	Brake fluid	SAE J 1703 - FMVSS 116 - DOT 3/4 - ISO 4925 - CUNA NC 956 DOT 4 synthetic fluid

NOTE

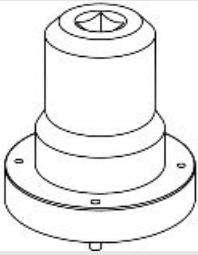
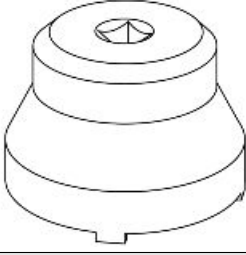
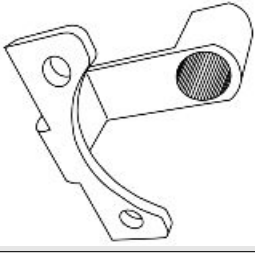
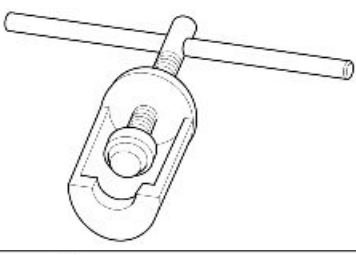
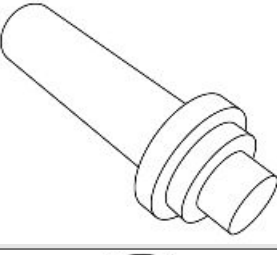
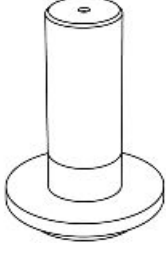
USE ONLY NEW BRAKE FLUID. DO NOT MIX DIFFERENT BRANDS OR TYPES OF OIL WITHOUT CHECKING THEIR BASE COMPATIBILITY.


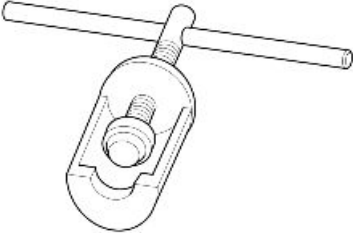
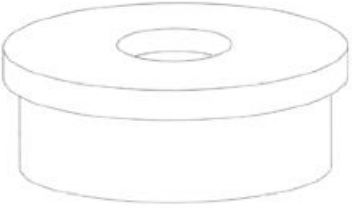

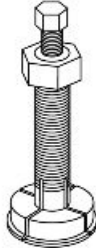
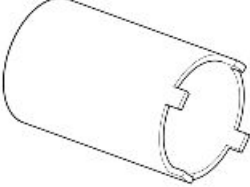

INDEX OF TOPICS


SSPECIAL TOOLS

S-TOOLS

SPECIAL TOOLS

Stores code	Description	
020998Y	Pinion case key	
020999Y	Crown ring nut key	
021000Y	Bevel gear pair support	
19.90.70.00	Extractor for internal ring on drilled bolt	
021003Y	Bevel gear oil seal punch	
021005Y	Punch seals on the bevel gear cover	

Stores code	Description	
GU19927900	Punch for pressing bearing inner ring on-to drilled pin	
GU19907000	Extractor for internal ring on drilled bolt	
020360Y	52 x 55-mm Adaptor	
020376Y	Adaptor handle	
001467Y036	Extract the inner bearing track	
AP8140190	Tool for steering tightening	
020922Y	P.A.D.S.	

Stores code	Description	
020931Y	PADS instrument panel connection cable	

INDEX OF TOPICS

MAINTENANCE

MAIN

Scheduled maintenance table

NOTE

CARRY OUT MAINTENANCE OPERATIONS AT HALF THE INTERVALS SPECIFIED IF THE VEHICLE IS USED IN PARTICULAR RAINY OR DUSTY CONDITIONS, OFF ROAD OR FOR TRACK USE.

NOTE

THE TIMES LISTED ON THE SCHEDULED MAINTENANCE TABLE INCLUDE TIME DEDICATED TO MANAGEMENT ACTIVITIES.

I: INSPECT AND CLEAN, ADJUST, LUBRICATE OR REPLACE IF NECESSARY

V: CHECK AND CLEAN, ADJUST AND REPLACE IF NECESSARY

C: CLEAN, R: REPLACE, A: ADJUST, L: LUBRICATE

(1) Replace in case of leaks.

(2) Replace every 2 years or 20,000 Km (12,427.42 mi).

(3) Replace every 4 years.

(4) At each engine start.

(5) Check every month.

(6) Check every 3000 km (1864.11 mi)

(7) Check and clean and adjust or replace, if necessary, every 1000 Km (621.37 mi)

(8) Replace at whichever of the following occurs first: 40000 km (24854.85 mi) or 4 years

ROUTINE MAINTENANCE TABLE

km x 1,000 (mi x 1,000)	1.5 (0.9)	10 (6.2)	20 (12.4)	30 (18.6)	40 (24.9)	50 (31.1)	60 (37.3)
Spark plugs		R	R	R	R	R	R
Filter box (9)		C	C	C	C	C	C
Transmission cables and controls	I	I	I	I	I	I	I
Steering bearings and steering clearance	I	I	I	I	I	I	I
Wheel bearings		I	I	I	I	I	I
Diagnosis by tool	I	I	I	I	I	I	I
Brake discs	I	I	I	I	I	I	I
Air filter		R	R	R	R	R	R
Oil filter change	C						C
Engine oil filter	R	R	R	R	R	R	R
Lights operation / aiming		I	I	I	I	I	I
Vehicle general operation	I	I	I	I	I	I	I
Rear wheel flexible coupling rubbers						R	
Braking systems	I	I	I	I	I	I	I
Light circuit	I	I	I	I	I	I	I
Safety switches	I	I	I	I	I	I	I
Brake fluid (2)	I	I	I	I	I	I	I
Gearbox oil	R						R
Fork oil (8)					R		
Engine oil (6)	R	R	R	R	R	R	R
Final drive oil				R			R
Fork oil seal (1)	I	I	I	I		I	I
Tyres - pressure/wear (5)	I	I	I	I	I	I	I
Valve clearance adjustment	A	A	A	A	A	A	A
Wheels	I	I	I	I	I	I	I
Bolts and nuts tightening	I	I	I	I	I	I	I
Battery terminals tightening	I						
Suspension and setting	I		I		I		I
Engine oil pressure warning light (4)							
Filter box drain plug	C	C	C	C	C	C	C

km x 1,000 (mi x 1,000)	1.5 (0.9)	10 (6.2)	20 (12.4)	30 (18.6)	40 (24.9)	50 (31.1)	60 (37.3)
Fuel lines (3)							
Brake pipes							
Clutch wear							
Brake pads wear (7)	V	V	V	V	V	V	V
Labour time (minutes)	110	90	100	90	130	90	110

NOTE

AT EACH SCHEDULED MAINTENANCE MUST BE VERIFIED WITH THE DIAGNOSTIC TOOL IF THERE ARE ERRORS AND THE IF THE PARAMETERS ARE CORRECT. MAKE SURE THAT THE VEHICLE CALIBRATION IS UPDATED, AFTER PERFORMING THE UPDATE OF THE DIAGNOSTIC TOOL.

Transmission fluid

Check

- Keep the vehicle upright with both wheels on the ground.
- Unscrew and remove the cap/dipstick (1).
- The level is correct if the oil is close to the hole of the cap/dipstick (1).
- If the oil is lower than specified, top-up until it reaches the cap/dipstick hole (1).

**CAUTION**

DO NOT ADD ADDITIVES OR OTHER SUBSTANCES TO THE FLUID. WHEN USING A FUNNEL OR ANY OTHER ELEMENT, MAKE SURE IT IS PERFECTLY CLEAN.

Replacement

CAUTION

THE UNIT MUST BE HOT WHEN THE OIL IS CHANGED AS UNDER SUCH CONDITIONS OIL IS FLUID AND THEREFORE EASY TO DRAIN.

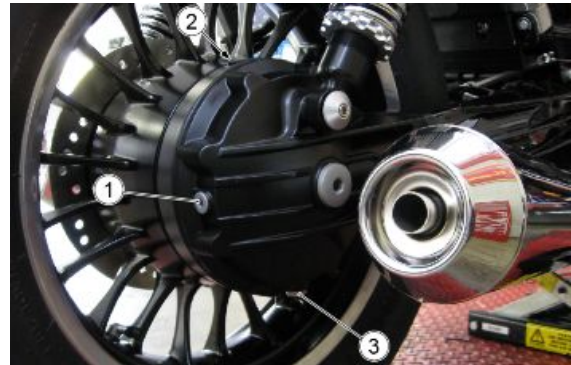
NOTE**RIDE SOME km (miles) TO WARM UP ENGINE OIL**

- Place a container with + 400 cm³ (25 cu in) capacity under the drainage plug (3).
- Unscrew and remove the drainage plug (3).
- Unscrew and remove the breather cap (2).
- Drain the oil into the container; allow several minutes for oil to drain out completely.
- Check and if necessary, replace the sealing washer of drainage plug (3).
- Remove any metal scrap attached to the drainage plug (3) magnet.
- Screw and tighten the drainage plug (3).
- Pour new oil through the fill opening (1) until it reaches the cap/dipstick hole (1).

CAUTION

DO NOT ADD ADDITIVES OR OTHER SUBSTANCES TO THE FLUID. WHEN USING A FUNNEL OR ANY OTHER ELEMENT, MAKE SURE IT IS PERFECTLY CLEAN.

- Screw and tighten the caps (1 - 2).



Engine oil

Check

CAUTION

ENGINE MUST BE WARM TO CHECK ENGINE OIL LEVEL.



ENGINE OIL LEVEL MUST BE CHECKED WHEN THE ENGINE IS WARM AND WITH THE DIPSTICK INSERTED BUT NOT SCREWED IN.

IF YOU CHECK LEVEL WHEN THE ENGINE IS COLD, OIL LEVEL COULD TEMPORARILY DROP BELOW THE 'MIN' MARK.

THIS SHOULD NOT BE CONSIDERED A PROBLEM PROVIDED THAT THE ALARM WARNING LIGHT AND THE ENGINE OIL PRESSURE ICON DISPLAY DO NOT TURN ON SIMULTANEOUSLY.

NOTE

DO NOT LET THE ENGINE IDLE WITH THE VEHICLE AT STANDSTILL TO WARM UP THE ENGINE OIL AND REACH THE OPERATING TEMPERATURE OF ENGINE OIL. OIL IS BEST CHECKED AFTER RUNNING FOR ABOUT 15 KM (10 miles).

- Switch off the engine and wait at least five minutes to allow the lubricant to drain back into the sump.
- Keep the vehicle upright with both wheels on the ground.
- Unscrew and remove the cap with dipstick.
- Clean dipstick.
- Refit the cap with dipstick into its hole without tightening.
- Remove the cap with dipstick.
- Check oil level by means of the oil dipstick.
- The oil level is correct when it close to the "MAX" mark.

MAX = maximum level

MIN = minimum level

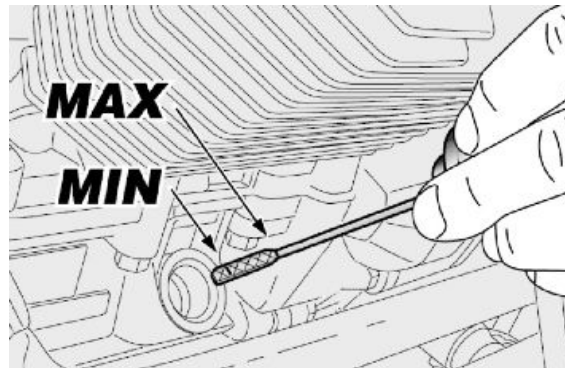
Add engine oil if required:

- Unscrew and remove the cap with dipstick.

- Top-up with engine oil until it goes above the minimum level marked "MIN".

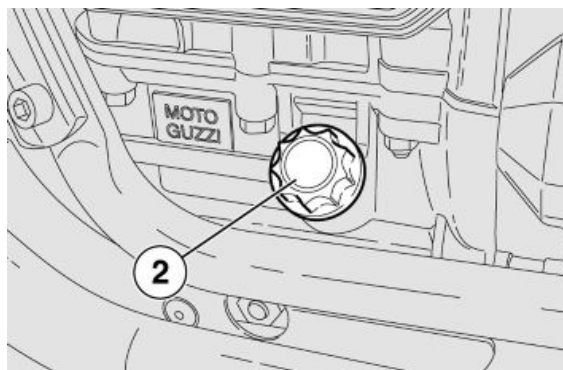
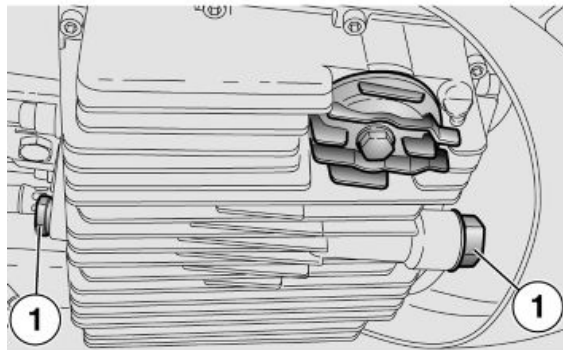
CAUTION

DO NOT ADD ADDITIVES OR OTHER SUBSTANCES TO THE FLUID. WHEN USING A FUNNEL OR ANY OTHER ELEMENT, MAKE SURE IT IS PERFECTLY CLEAN.



Replacement

- Place a container with 2000 cm³ (122.05 cu.in) capacity under the drainage plugs (1).
- Unscrew and remove the drainage plugs (1).
- Unscrew and remove the filler plug (2).
- Drain the oil into the container; allow several minutes for oil to drain out completely.
- Check and, if necessary, replace the sealing washers of drainage plugs (1).
- Remove any metal scrap attached to the magnet of drainage plugs (1).
- Screw and tighten the drainage plugs (1).



Tightening torque for drainage plugs (1): 12 Nm (8.85 lb ft).

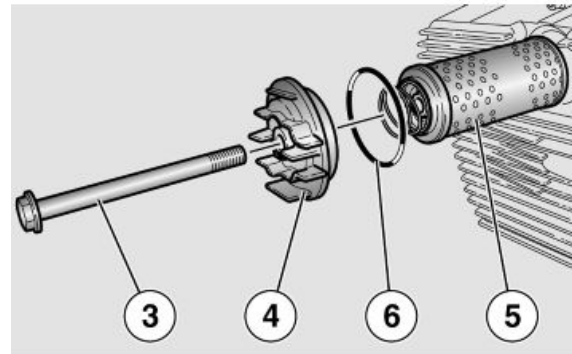


DO NOT DISPOSE OF OIL INTO THE ENVIRONMENT. DISPOSE OF ENGINE OIL IN A SEALED CONTAINER AND TAKE IT TO YOUR SUPPLIER OR TO THE NEAREST USED OIL COLLECTION CENTRE.

Engine oil filter

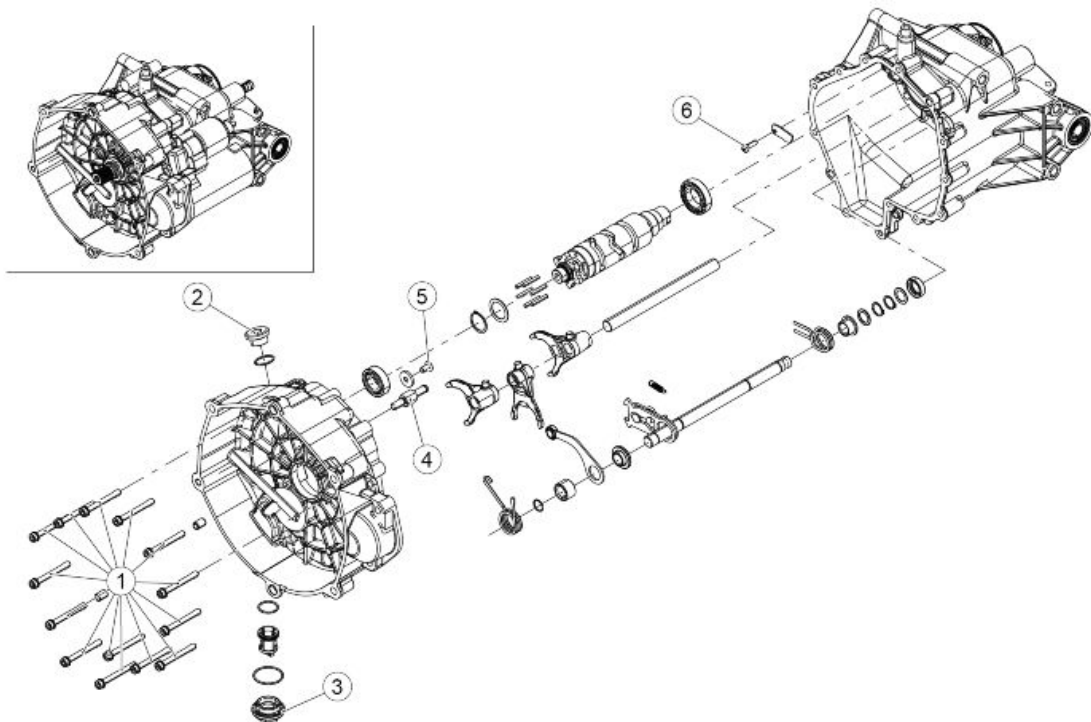
- Undo the two screws (3) and remove the cover (4).
- Remove the engine oil filter (5).

NOTE
NEVER REUSE AN OLD FILTER.



- Spread a thin layer of oil on the sealing ring (6) of the new engine oil filter.
- Fit the new engine oil filter with the spring facing downwards.
- Refit the cover (4), screw and tighten the screw (3).

Gearbox Oil



COMPLETE GEAR - SELECTOR - DESMODROMIC

pos.	Description	Type	Quantity	Torque	Notes
1	Gearbox fixing SHC screws	M6x55	14	9-11 Nm (6.64-8.11 lbf ft)	-
2	Oil load cap	M20x1.5	1	23-27 Nm (16.96-19.91 lb ft)	-
3	Oil filter cap	M28x1	1	25-30 Nm (18.44-22.13 lb ft)	-
4	Pre-selector pin	M8	1	18-22 Nm (18.28-16.23 lb ft)	Loct. DRI 2040

pos.	Description	Type	Quantity	Torque	Notes
5	Washers fixing countersunk head screws	M6x12	5	9-11 Nm (6.64-8.11 lbf ft)	Loct. DRI 2045
6	Plate fixing torx screw	M5x16	1	6-7 Nm (4.42-5.16 lb ft)	Loct. DRI 2045

Replacement

NOTE

HOT OIL IS MORE FLUID AND WILL DRAIN OUT MORE EASILY AND COMPLETELY.

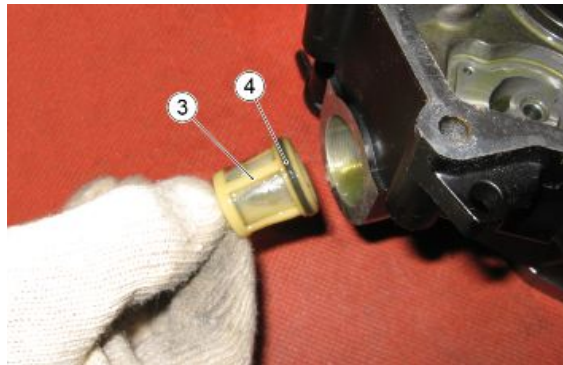
- Place a container with suitable capacity under the drainage plug (2).
- Unscrew and remove the drainage plug (2).



- Unscrew and remove the filler plug (1).
- Drain the oil into the container; allow several minutes for oil to drain out completely.
- Check and if necessary, replace the sealing washers of drainage plug (2).
- Remove any metal scrap attached to the drainage plug (2) magnet.



- Remove the air filter (3) and clean it
- Check the O-Ring (4) and if necessary replace it
- Screw and tighten the drainage plug (2)



- Pour in new oil, observing the quantity indicated in the table "capacity"
- Tighten the filler cap (1).

CAUTION

DO NOT ADD ADDITIVES OR OTHER SUBSTANCES TO THE FLUID. WHEN USING A FUNNEL OR ANY OTHER ELEMENT, MAKE SURE IT IS PERFECTLY CLEAN.

Throttle body removal

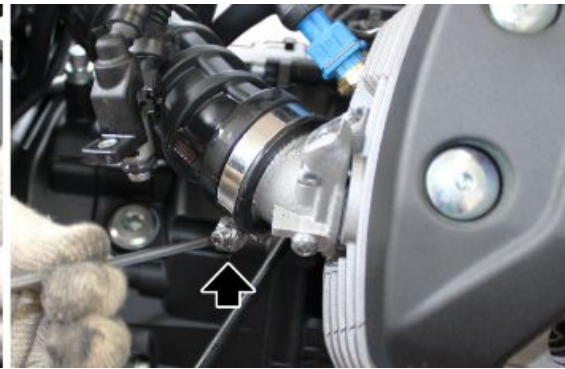
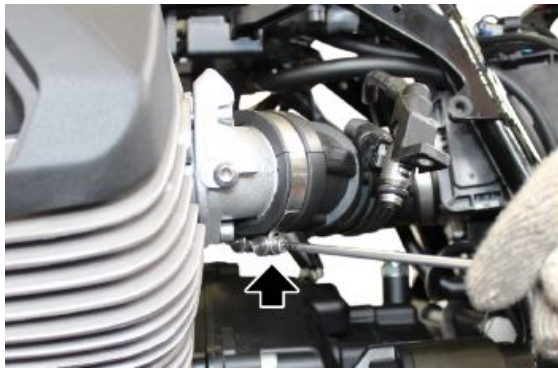
- Remove the clip clamp fixing the sleeve to the filter box

CAUTION

DURING REFITTING, REPLACE THE CLIP CLAMP



- Loosen the clamps that secure the sleeve to the intake manifolds



- Remove the sleeve



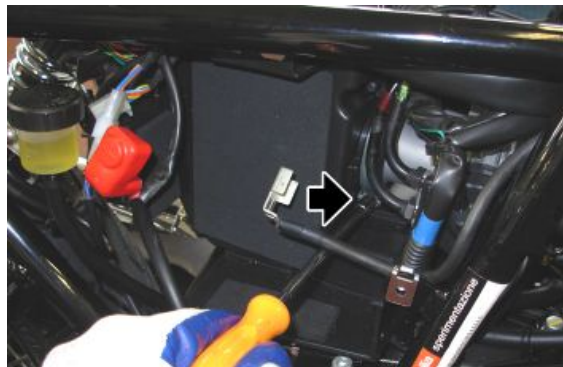
- Remove the battery
- Remove the MIU G3 control unit connector support bracket fixing screw



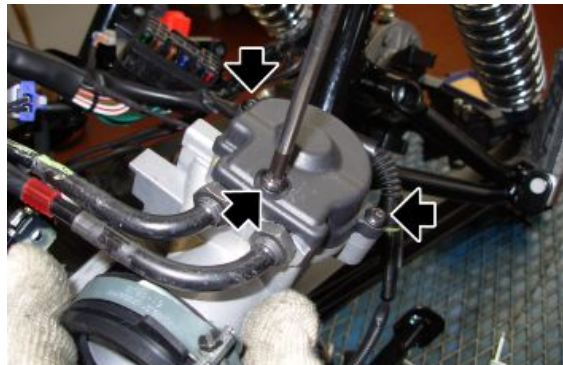
- Disconnect the MIU G3 control unit connector



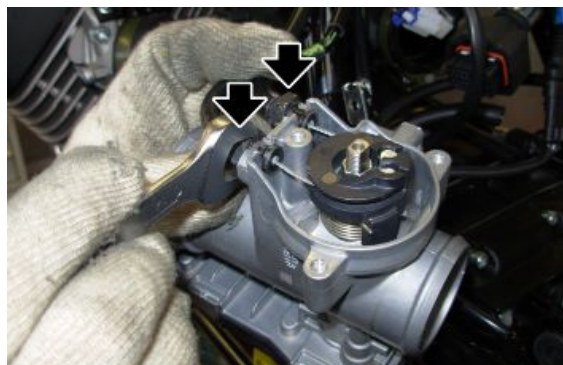
- Unscrew the clamp that secures the throttle body to the filter box
- Extract the throttle body laterally

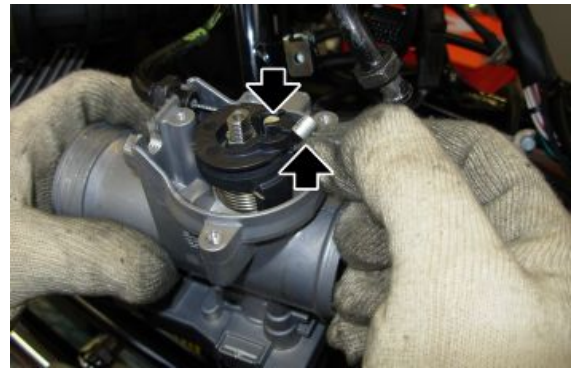


- Remove the throttle body guard



- Loosen the gas cables fixing nuts on the throttle body and unhook them





- Remove the throttle body

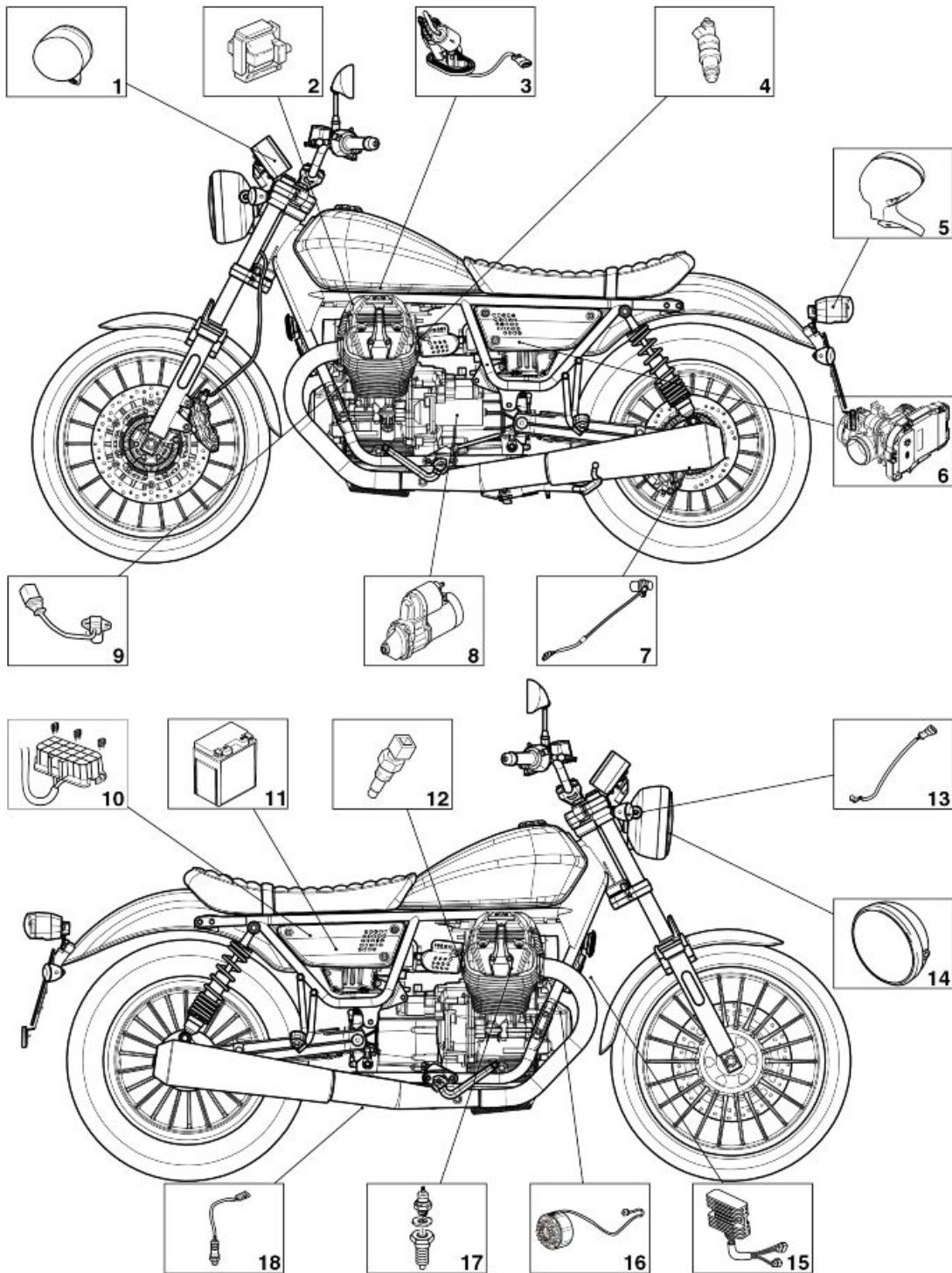
Braking system

INDEX OF TOPICS

ELECTRICAL SYSTEM

ELE SYS

Components arrangement



key:

- 1. Instrument panel
- 2. Coil
- 3. Fuel pump

4. Injector
 5. Taillight
 6. MIU G3 Control Unit
 7. Speed sensor
 8. Starter motor
 9. Engine speed sensor
 10. Fuses
 11. Battery
 12. Head temperature sensor
 13. Instrument panel air sensor
 14. Headlamp
 15. Voltage regulator
 16. Alternator
 17. Oil pressure sensor
 18. Lambda probes
-

Electrical system installation

INTRODUCTION

Scope and applicability

The position of the wiring harnesses, how they are fixed to the motorcycle and potential problems are defined on the following sections in order to reach the objectives of vehicle reliability.

Materials used and corresponding quantities

The electrical system consists of the following wiring harnesses and parts:

- 1 Vehicle wiring harness
- 1 Headlamp wiring harness
- 2 ABS speed sensor
- 1 Horn
- 2 Oxygen sensor
- 1 Stand switch
- 1 Fall sensor (grey connector)

Small parts and mountings

- 11 Large black 290x4 clamps
- 4 Small black 160x2.5 clamps
- 1 Small cable guide rubber clamp
- 2 Large cable guide rubber clamps
- 1 ECU bracket
- 2 Connector supports

- 1 Cable grommet
- 1 Black sheath
- 7 ABS Cable grommets
- 1 connector clip

Motorcycle division

The wiring timing is subdivided in three essential sections, as indicated in the figure.

1. Front section
2. Central section
3. Rear section



SPECIAL CHECKS FOR THE CORRECT CONNECTION AND LAYING OF CABLES

It is extremely important that any security-locks for the following connectors are properly connected and correctly tightened to ensure proper engine, and therefore proper vehicle, operation.

Carry out the checks listed below.

- Instrument panel connector (is engaged and the boot well inserted)
- Rear and front wheel ABS sensor connector
- Check the correct routing of the rear turn indicators cables on the license plate holder (RH and LH)
- Check the correct closing of the ABS ECU and the correct routing of the branch on the conduit
- Taillight connector
- Right and Left light switch connectors
- Clutch connector
- Connector ignition switch connector (check that the cable is not live)
- Immobilizer antenna connector
- ECU connector (G3) and the correct insertion of the relative rubber plug
- Check the correct fastening of metallic bracket screw on the throttle body
- Check securing of the battery positive cable on the starter motor. Check if the cap is well inserted
- Check the insertion of the starter motor faston
- Check the correct passage and fixing of the ABS fuse
- Check the right and left injectors connection
- Check the connection of the engine head temperature sensor
- Check the correct insertion of H.V. Cables with the Coils (RH and LH)
- Check whether the Grey H.V. Cable connects on the Coil with the Grey tape

- Check whether the Grey H.V. Cable goes to the Left engine head
- Check the coils connection (and their correct positioning on the frame)
- Check the correct insertion of the engine oil cap
- Check ground fastening on the engine
- Check NEUTRAL cable fastening
- Check whether the right lambda probe is connected to the output labelled "LAMBDA DX" (RH LAMBDA)
- Check the Regulator and Flywheel connection
- Check whether the right and left lambda probe cable is inserted on the cable grommet under the clutch housing
- Check the right Lambda connections
- Check the Pick Up connection
- Check correct insertion of the starter motor hood and engine start Faston
- Check the presence of the Red protective hood on the battery Positive
- Check that the stand switch connector is blue and clamped
- Check the side stand connection and the left lambda
- Check the rear stop connection
- Check the stand switch cable ties on the frame under the vehicle
- Check the assembly of the fall sensor (if the arrow is upwards and the connector is grey)
- Check the connection of the secondary air valve and the correct positioning of the cap
- Check the connection of the front stop faston.

CAUTION

THE ENCIRCLED CONNECTORS ARE CONSIDERED CRITICAL IN COMPARISON WITH ANY OTHER BECAUSE THE VEHICLE WILL STOP OR PRESENT A MALFUNCTION IF THEY ARE ACCIDENTALLY DISCONNECTED.

Undoubtedly the connection of the rest of connectors is also important and essential for the correct operation of the vehicle. It is also important and essential that the instructions regarding the routing and fixing of the wiring harness in the various areas are followed meticulously in order to guarantee functionality and reliability

COMPONENTS PRE-FITTING**TABLE A - ENGINE**

- Check that the HV cable of the left cylinder has grey taping

**TABLE B - REAR COIL ON THE FRAME**

- Check that the coil in this position has the connector (wiring harness side) with two contacts

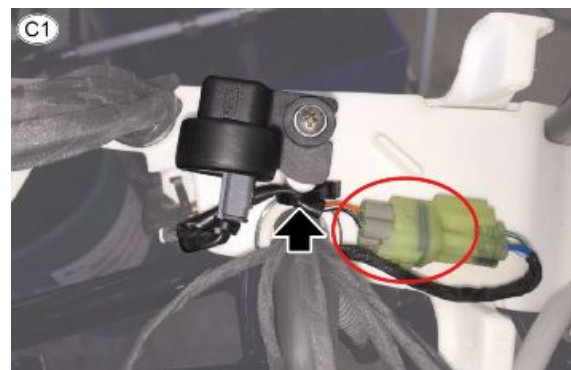


TABLE C - CONDUIT

- Check that the fall sensor arrow is upwards and that the connector is grey



- Place a large clamp so that the sensor cable is positioned as indicated



- Check that the ABS control unit cable is backwards, as illustrated in the image



Front side

TABLE A - FRONT WHEEL ABS SENSOR PASSAGE

1. Front ABS sensor
2. Cable grommet
 - Pass the front ABS sensor wiring harness through the cable grommet as indicated.



- Connect the front ABS sensor wiring harness with the brake pipe using cable guides (3)



- Pass the ABS sensor wiring harness around the steering column and through the metallic cable grommet (4) on the frame

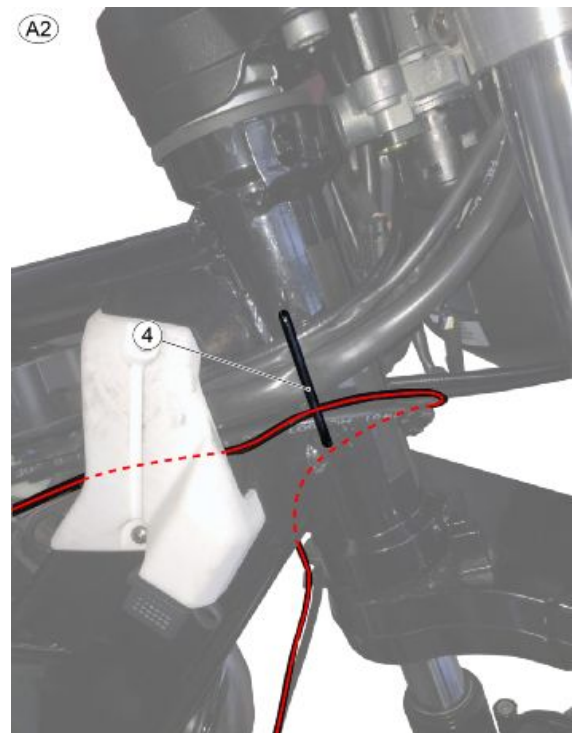


TABLE B - STEERING LIGHTS CABLE PASSAGE ON THE HANDLE BAR

- Using the cable guides (1), fasten the RH light switch wiring harness with the throttle cable
- Using the cable guide (2), fasten the front stop switch wiring harness with the front brake pipe
- Using the cable grommets (3), fasten the LH light switch wiring harness with the clutch cable

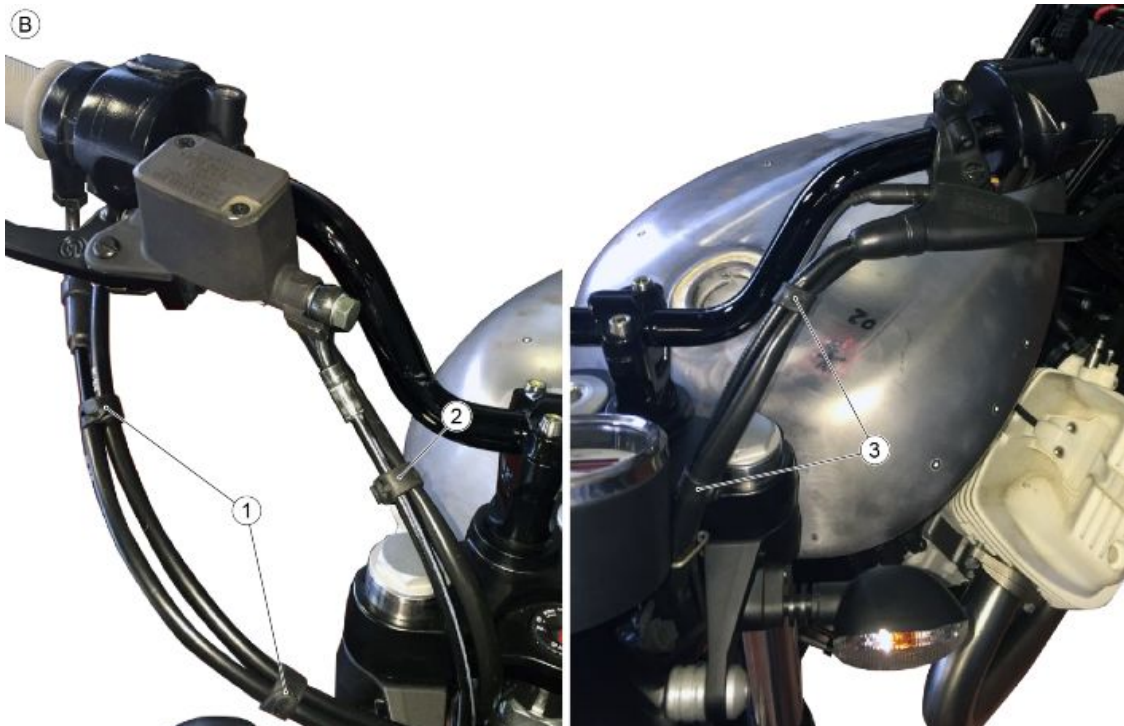
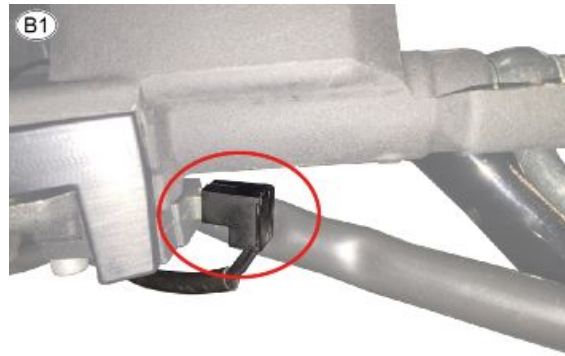
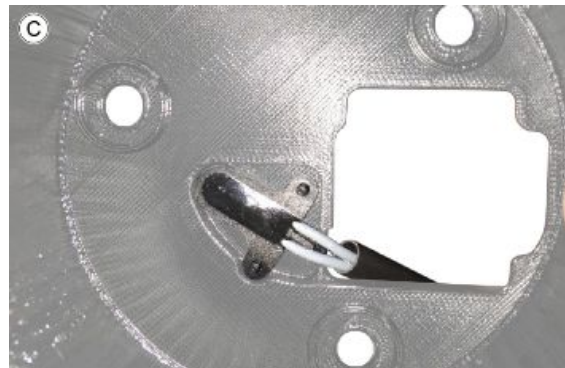


TABLE B1

- Check that the front stop fastons are well fastened, by slightly pulling them

**TABLE C - PRE-FITTING OF THE EXTERNAL AIR SENSOR ON THE INSTRUMENT PANEL CAP**

- Place the external air temperature sensor in its seat on the instrument panel cap

**TABLE C1**

- Fasten the external air temperature sensor in its seat using an adhesive sponge strip sized 40x20x3 mm

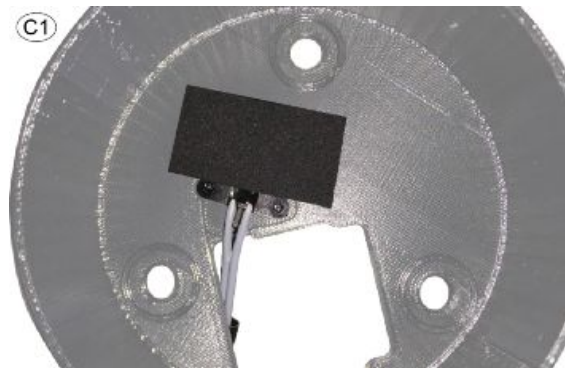


TABLE D - INSTRUMENT PANEL FITTING

- Use a medium sized clamp to fasten the instrument panel wiring harness with the external air temperature sensor, as illustrated

**TABLE D1**

- Check that the instrument panel connector is well fastened and that the protection case is well inserted

**TABLE E - USB SOCKET**

- Pass the USB socket wiring harness as indicated

**TABLE F - CABLE PASSAGE ON THE STEERING HEADSTOCK**

- Pass it on the sides of the steering headstock and through the cable grommets on the frame and under the side covers



Central part

TABLE A - CONDUIT ON THE FRAME

- Check that the relays (1) are well inserted
- Fasten the rear part of the conduit using a large clamp (2)

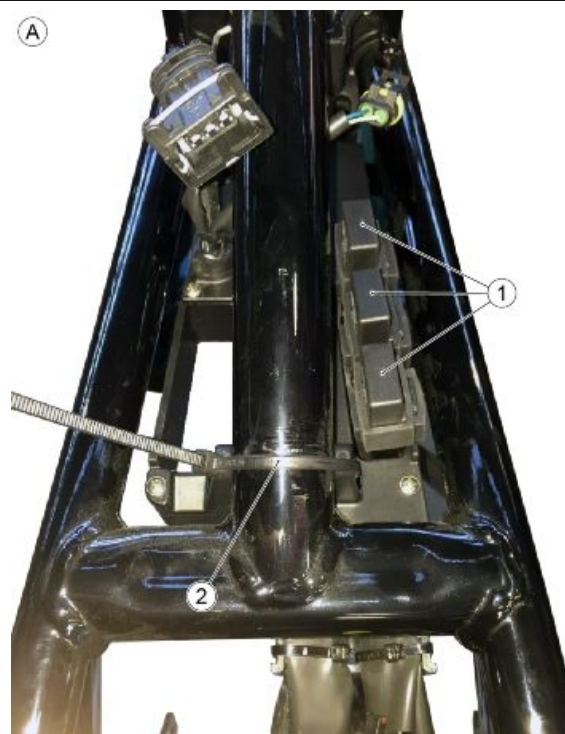


TABLE A1

- Pass the connector of the voltage regulator (1) and the horn connector (2) in the hole created by the conduit with the frame at the bottom, to facilitate their connection



TABLE A2

- Main wiring harness (1)



TABLE A3

- Right light switch connector (1)
- Left light switch connectors (2)
- Coil connector 2 (3)
- Front ABS sensor connector (4)
- USB socket connector (5)
- Right turn indicator connector (6)

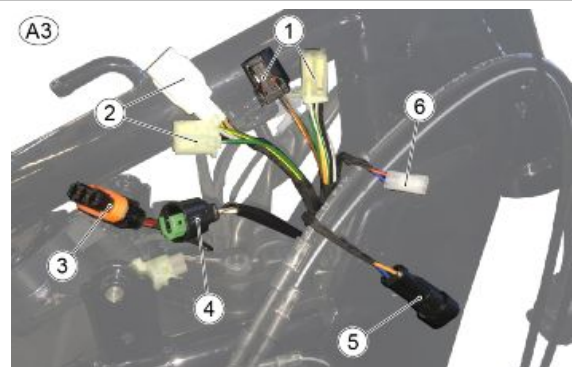
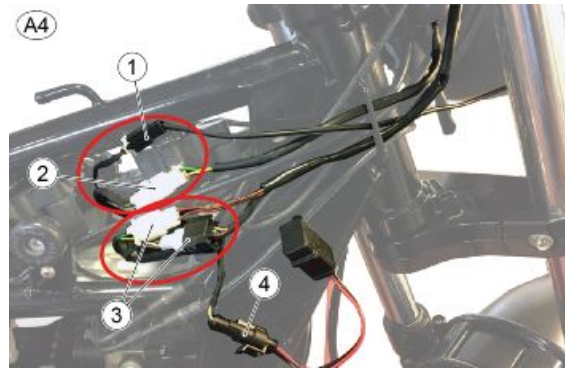
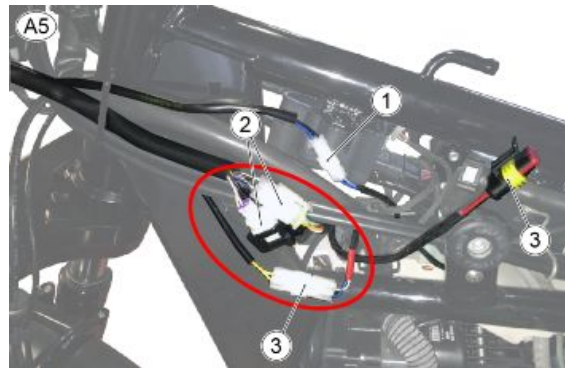


TABLE A4

- Key connector (1)
- Immobilizer antenna connector (2)
- Right light switch connector (3)
- USB socket connector (4)

**TABLE A5**

- Left arrow connector (1)
- Left light switch connectors (2)
- Clutch switch connector (3)
- Fuel pump connector (4)

**TABLE A6**

- Pass t the PICK-UP connector (1) on the right side of the frame

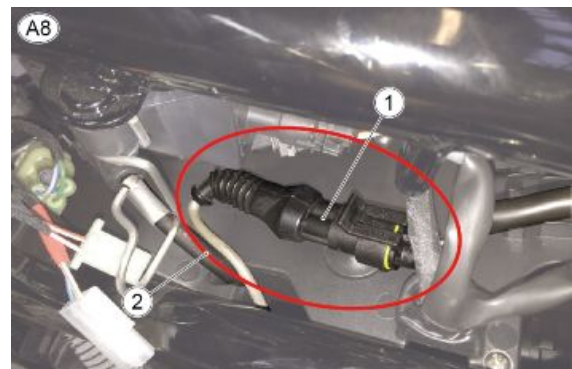


TABLE A7

- Check that the connector of the coil (1) is well coupled

**TABLE A8**

- Check that the connector of the engine head temperature sensor (1) is well coupled
- The HV cable (2) must remain inside the conduit groove

**TABLE B - COIL AND LEFT CYLINDER CONNECTION**

- Check that the HV cable with grey mark (left engine head) is well inserted in the coil with grey mark on the connector

**TABLE C - COIL AND RIGHT CYLINDER CONNECTION**

- Check that the HV cable without grey mark (right engine head) is well inserted in the front coil

**TABLE D - PROCEDURE FOR CORRECTLY FITTING THE ABS CONTROL UNIT CONNECTOR**

- The initial position of the connector fastener lever must be as shown in the figure

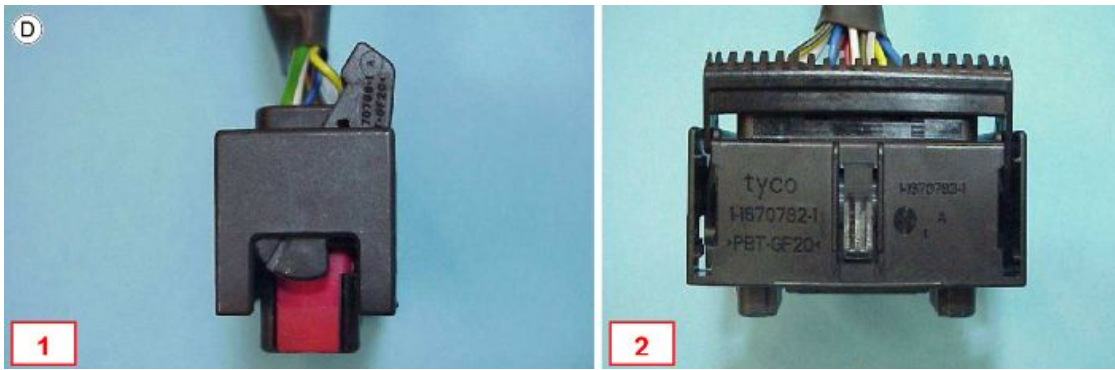


TABLE D1

- Place the connector on the opposite side of the control unit and lower the driving lever until the "click" that signals the end of the stroke is heard.

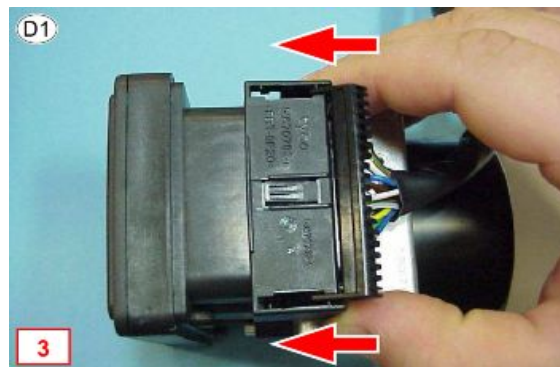


TABLE D2

- When the connector is fully inserted, the distance between the connector and the ABS control unit must be 7.5 mm (0.29 in)



TABLE D3

- If the initial position of the connector and driving lever is not as the one shown in "TABLE D". The connector will not be coupled correctly and the measured distance will be greater, approximately 12 mm (0.47 in). In this case, repeat the operations according to the instructions in "TABLES D1/D2". It is recommended to create a template to check the correct insertion of the connector.

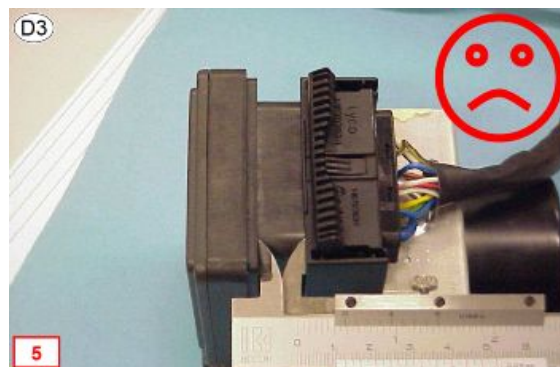
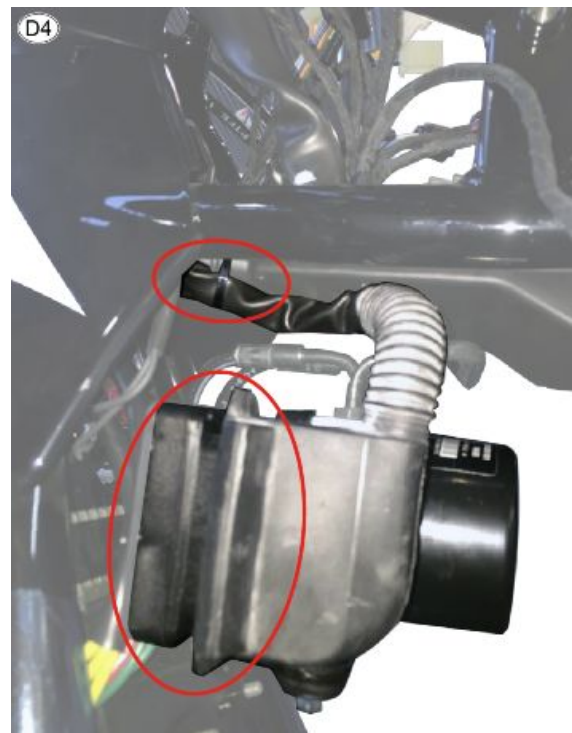
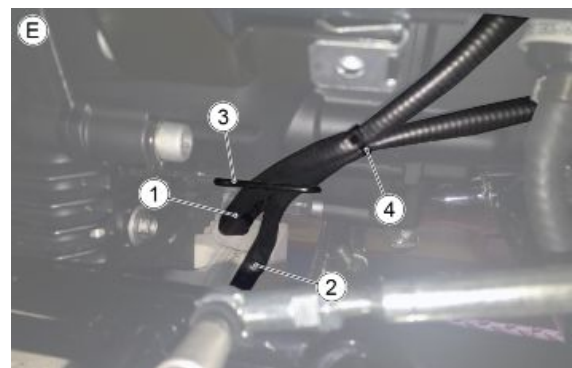


TABLE D4

- Check that the ABS control unit connector cap is well inserted and that the cable does not touch the frame

**TABLE E - LAMBDA PROBES PASSAGE UNDER THE ENGINE**

1. Right lambda probe wiring harness
2. Left lambda probe wiring harness
3. Cable grommet
4. Small clamp

**TABLE E1**

- Pass the wiring harness of the right lambda probe (1) and of the left lambda probe (2) under the starter motor, as indicated

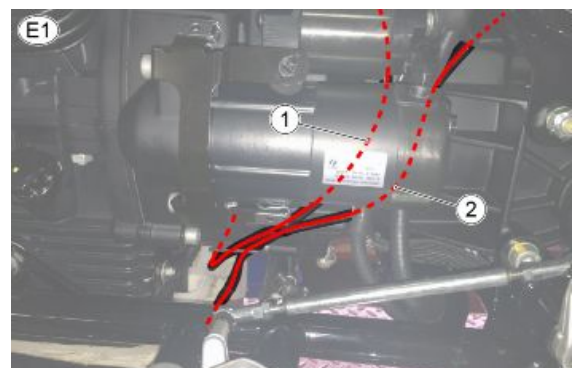
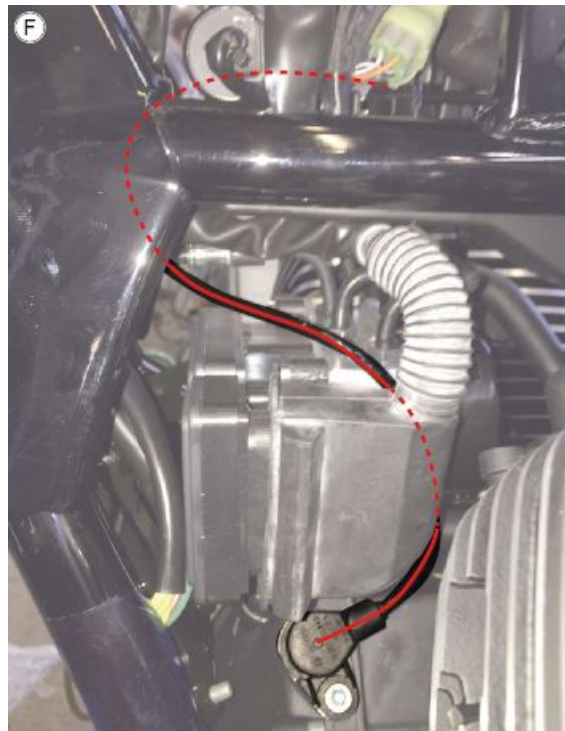


TABLE F - PICK UP CABLE PASSAGE

- Pass the pick up cable between the ABS modulator and the ABS connector

**TABLE F1**

- Pass the pick up cable through the central flap, towards the right side of the motorcycle

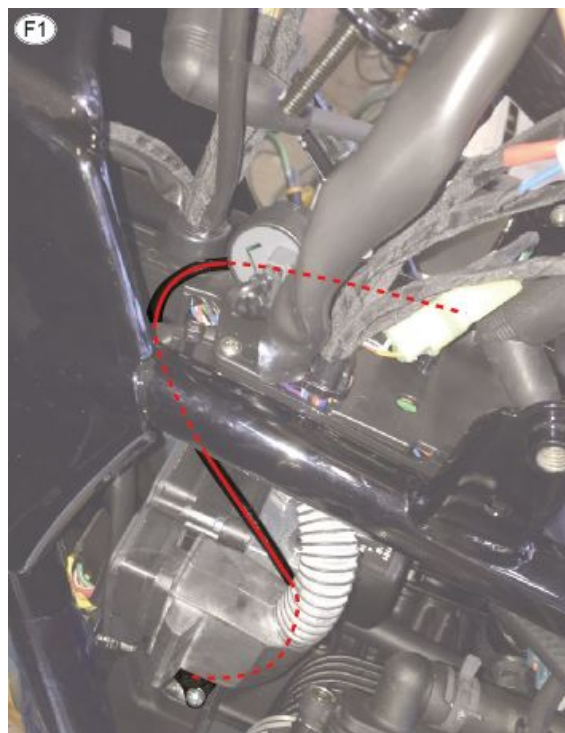
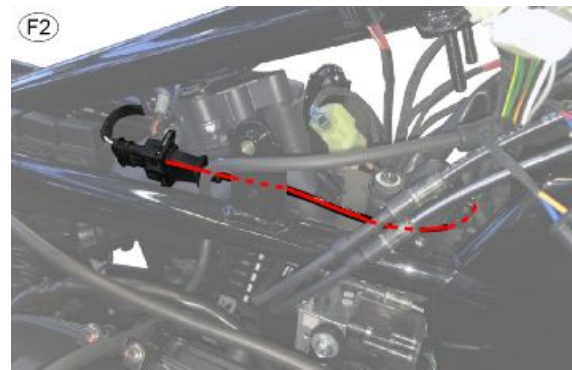


TABLE F2

- Pass the pick up cable to the back of the tank support and throttle cables

**TABLE F3**

- Check the correct connection of the pick up connector

**TABLE G - HORN AND REGULATOR**

1. Voltage regulator
 2. Horn
- The regulator's cable must pass behind the frame bracket

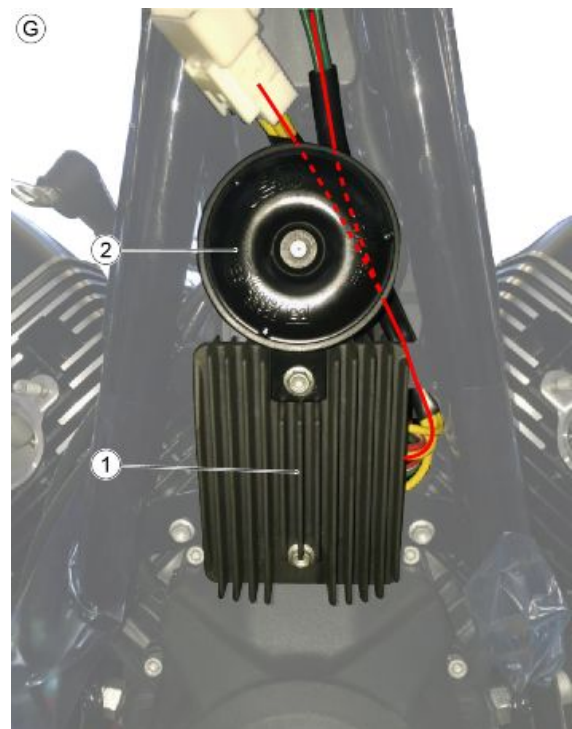


TABLE G1

- Check the connection of the flywheel white connector and regulator's black connector that must have a safety clamp to avoid disconnection.

**TABLE G2**

- Using a medium clamp, fasten the regulator's cables along the frame's tube

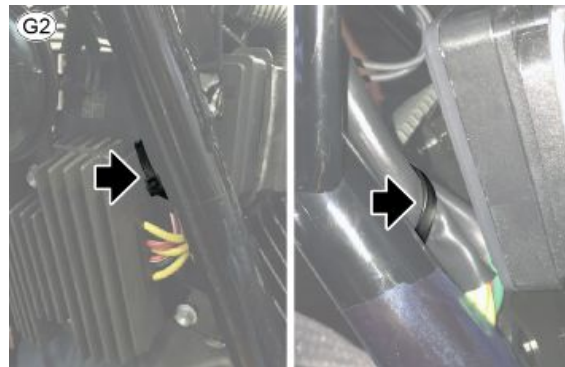
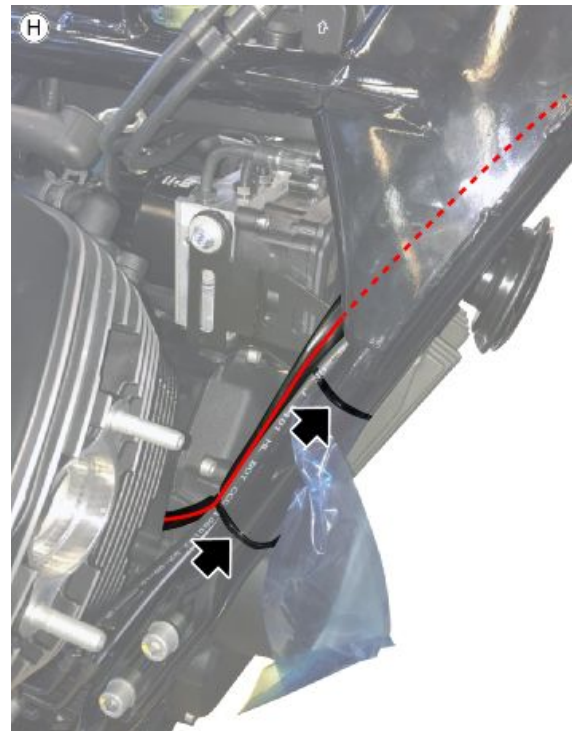


TABLE H - FLYWHEEL CABLES PASSAGE

- Using two medium clamps, fasten the flywheel's wiring harness

**TABLE I - NEUTRAL SENSOR CABLES PASSAGE**

- The wiring harness (1) of the neutral sensor must pass through the filter box support and in the cable guide (2)



TABLE J - OIL PRESSURE and SECONDARY AIR SENSORS

1. Oil pressure bulb
2. Secondary air system
3. Engine ground
4. Left injector
5. Right injector
6. Right Lambda probe
7. Battery ground

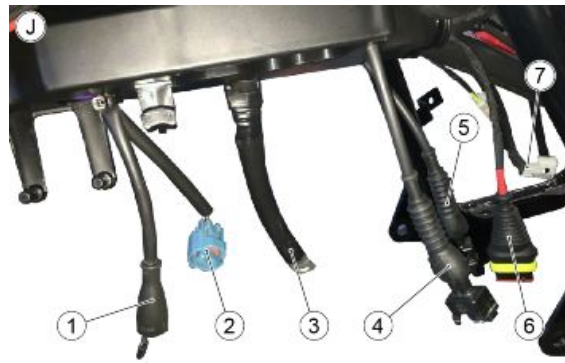


TABLE J1

- Check the correct connection of the oil pressure bulb connector (1) and of the secondary air connector (2)

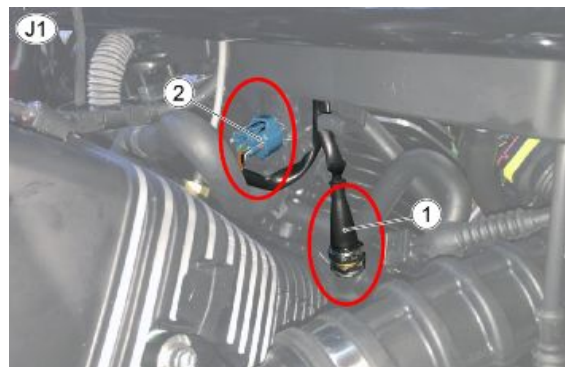


TABLE K - INJECTORS

- Check the correct connection of the injectors
- The cable of the engine head temperature bulb (1) must pass under the rubber pipe

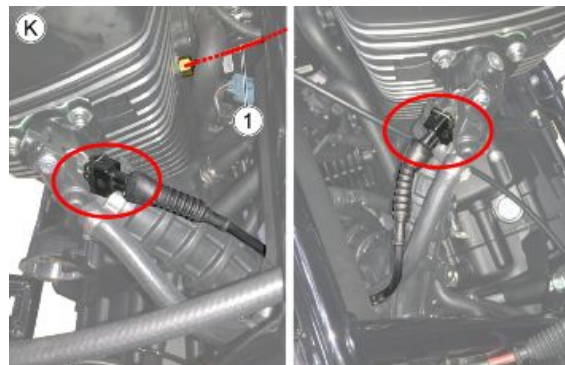


TABLE L - CONNECTION OF THE LEFT LAMBDA AND REAR ABS SENSOR

- Using a clamp, aligned with the frame flap fixing the side fairing, fasten the lambda probe wiring harness so that the cables are covered

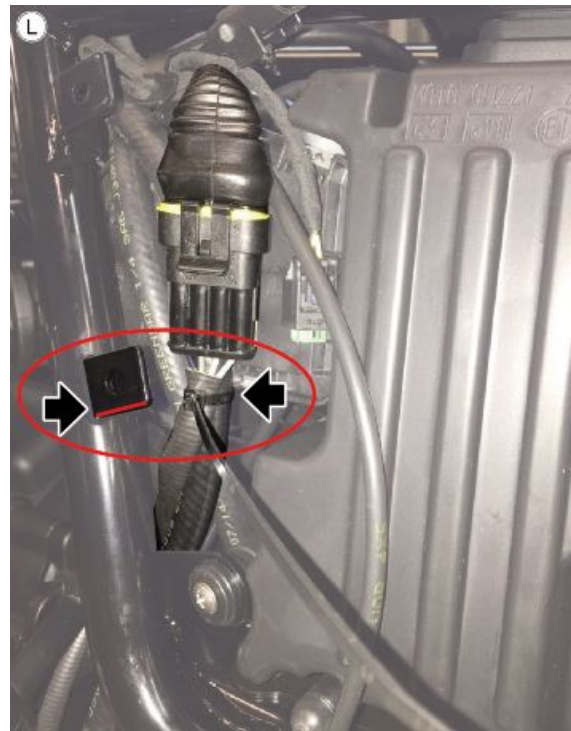


TABLE L1

- The wiring harnesses of the rear ABS sensor, the connector of the side stand and the faston for the starter motor must pass through the cable grommet (1)

THE CONNECTOR OF THE LEFT LAMBDA PROBE AND THE ANTI-THEFT FITTING MUST NOT PASS THROUGH THE CABLE GROMMET

- Check that the connector of the left lambda probe (2) and the rear ABS sensor (3) are correctly connected

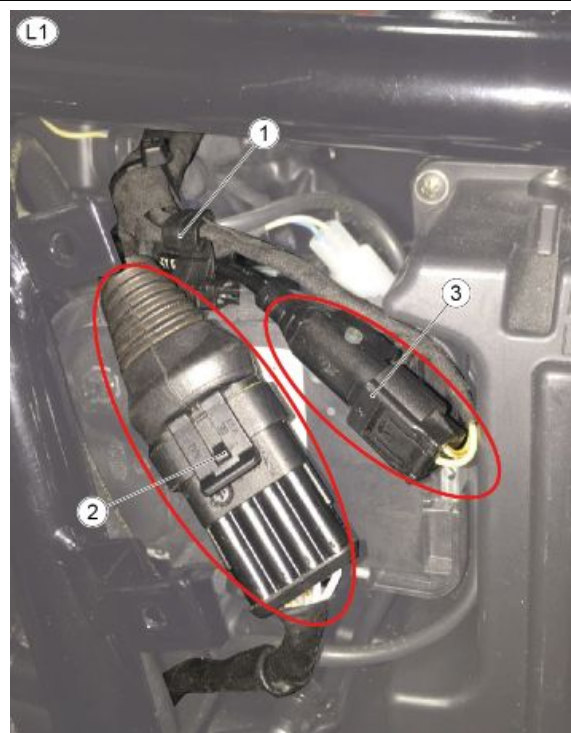
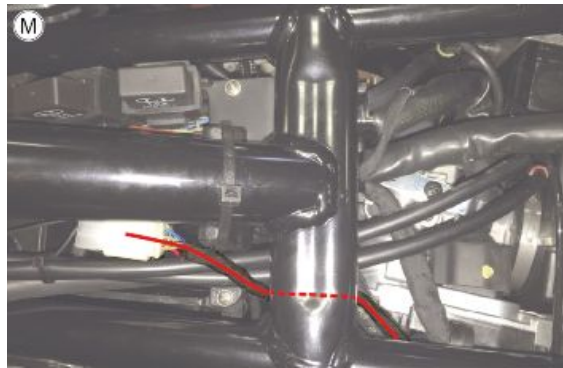
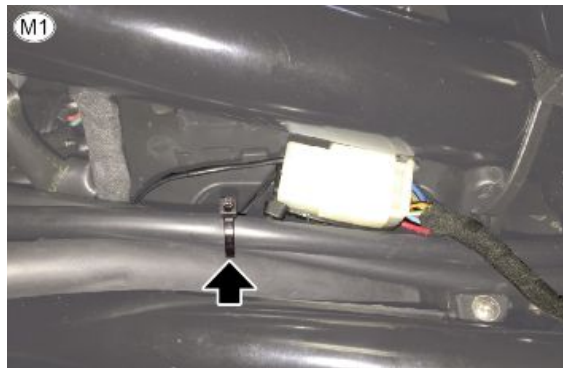


TABLE M - ANTI-THEFT FITTING POSITIONING

- The wiring harness of the anti-theft fitting must pass under the frame, as indicated

**TABLE M1**

- Using a small clamp, fasten the anti-theft connector to one of the two gas cables

**TABLE N - RIGHT EXHAUST LAMBDA and REAR BRAKE CONNECTION**

1. Check that the neutral sensor connector is well connected
2. Rear stop connector
3. Right Lambda probe connector



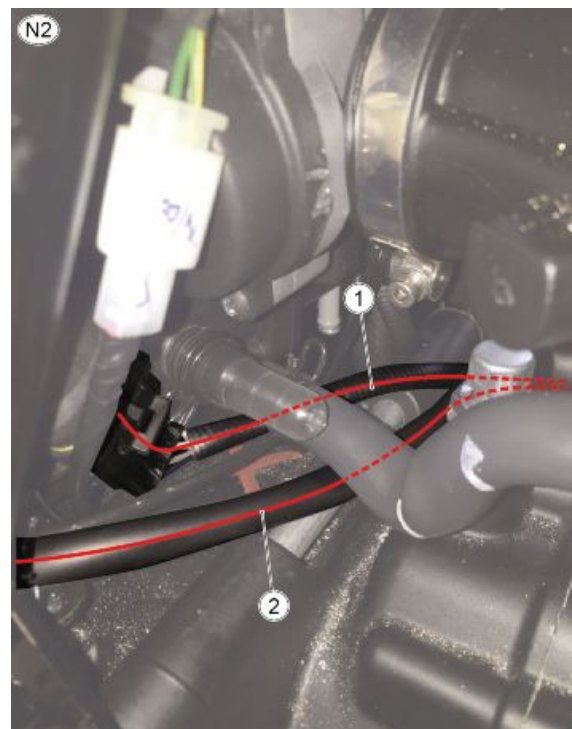
TABLE N1

- Check that the right lambda probe connector is well connected and that it is hooked to the specific support



TABLE N2

- The wiring harness of the lambda probe (1) must pass through the filter box and starter motor positive cable (2)

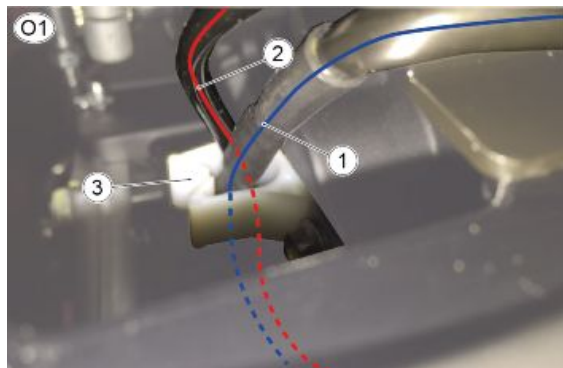


**TABLE O - REAR BRAKE WIRING HARNESS
PASSAGE**

- Check that the rear brake sensor connector is well connected

**TABLE O1**

- Pass the wiring harness of the rear brake sensor (1) and of the rear BAS sensor (2) through the cable grommet (3) mounted on the engine and inside the gearbox clutch lever.

**TABLE O2**

- Using a clamp, fasten the wiring harness of the rear brake sensor (1) to the wiring harness of the rear ABS sensor (2)
- The rear ABS sensor wiring harness must pass through the cable grommet (3)

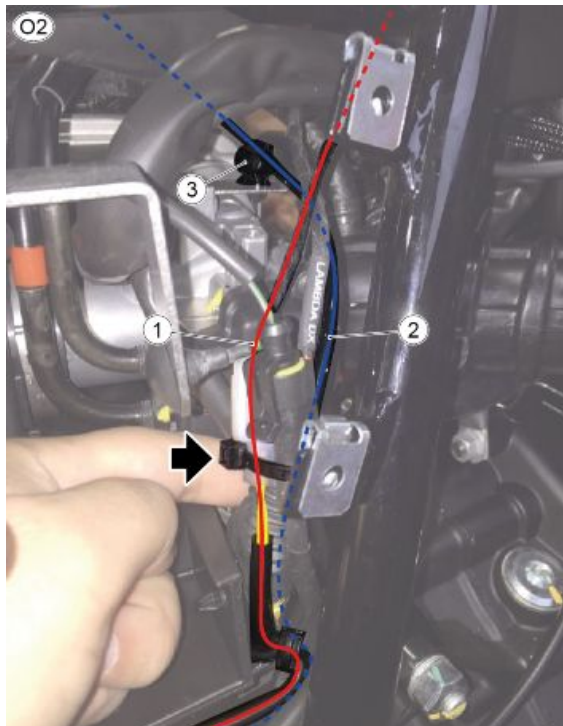
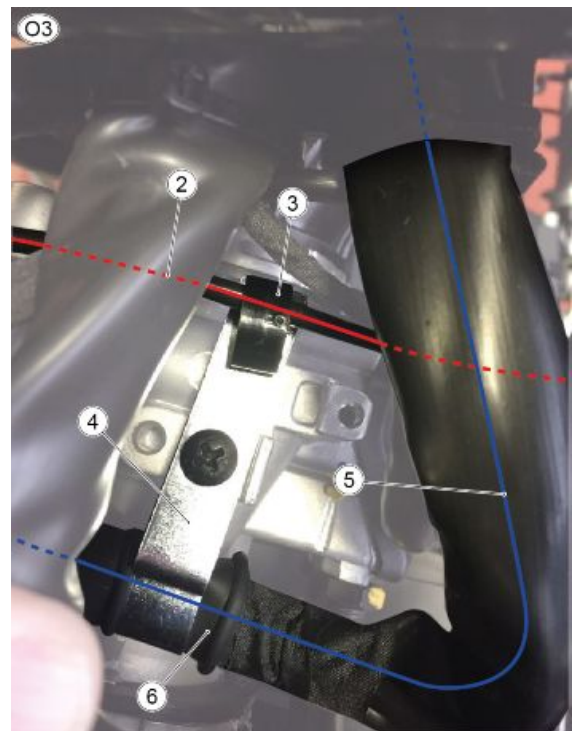
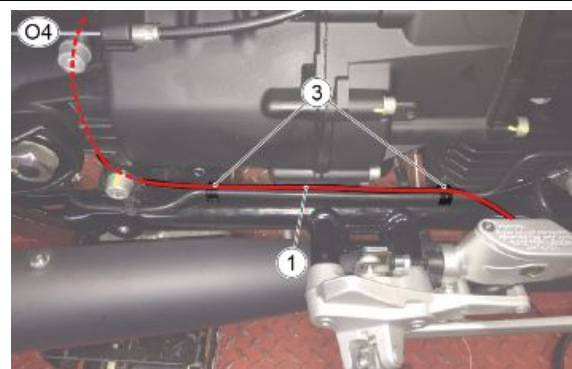


TABLE O3

- The wiring harness of the rear ABS sensor (2) must pass through the cable grommet (3) located on the bracket (4) that, in its turn, fixes the wiring harness of the engine control unit (5) in line with the rubber ring (6)

**TABLE O4**

- Fasten the wiring harness of the rear brake sensor (1) using the cable grommets (3)

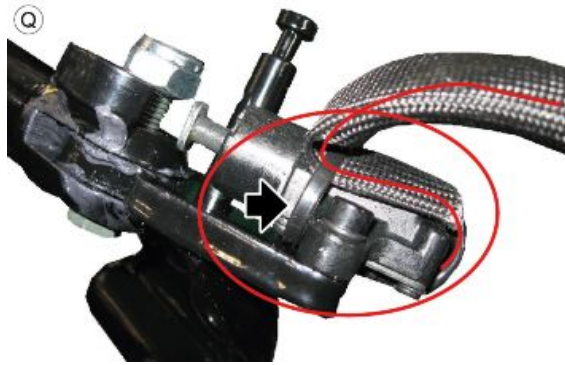
**TABLE P - ENGINE BATTERY GROUND**

- An incorrect fastening of the fixing screws of the engine battery ground eyelet may cause the vehicle to catch fire
- Check the tightening to the prescribed torque

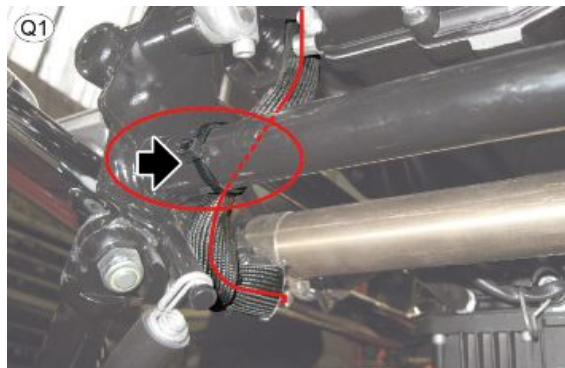


TABLE Q - SIDE STAND SENSOR

- Using a small clamp, fasten the wiring harness of the side stand switch, as indicated

**TABLE Q1**

- Using a medium clamp, fasten the wiring harness of the side stand switch to the frame

**TABLE Q2**

- Pass the wiring harness of the side stand switch under the starter motor power supply cable

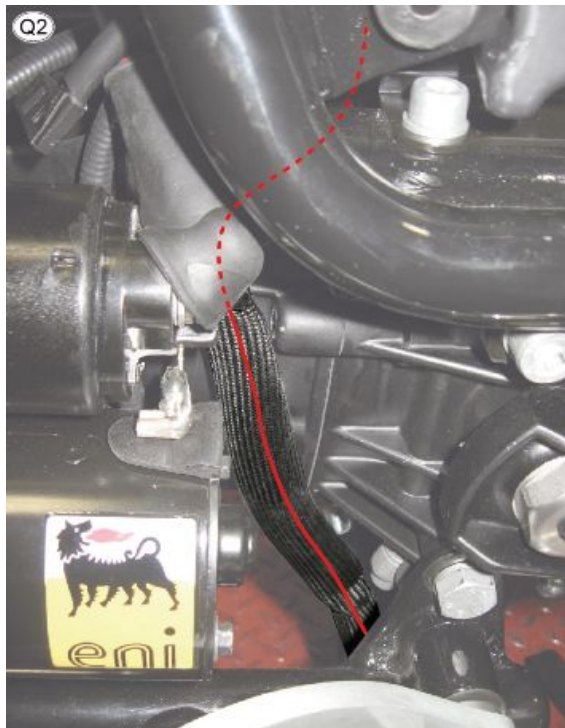
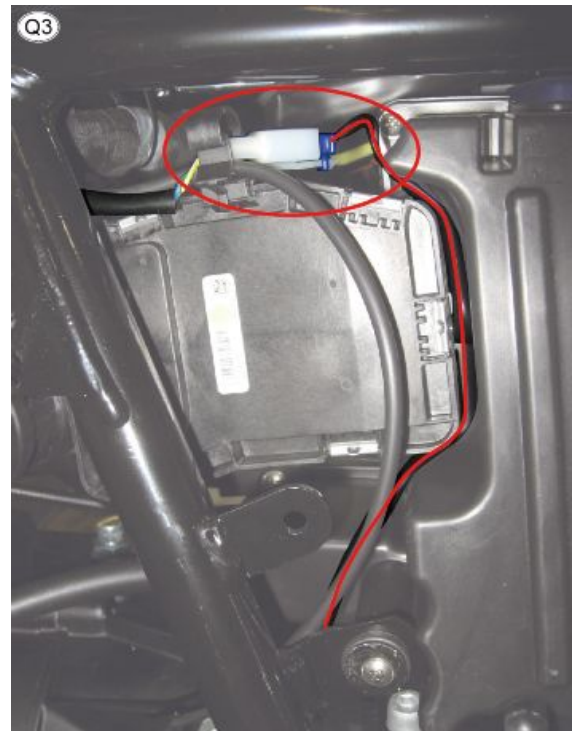
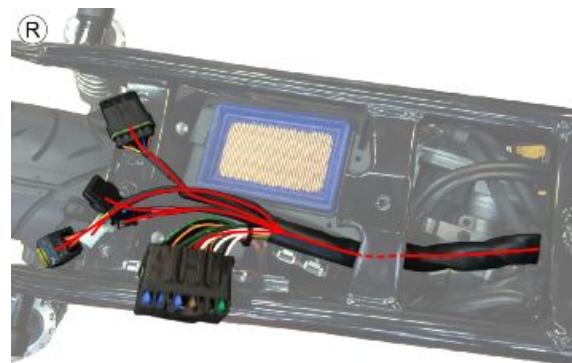


TABLE Q3

- Pass the wiring harness of the side stand switch behind the MIU G3 control unit and check that the connector is well connected

**TABLE R - ROUTING THE CABLES IN THE FILTER BOX/UNDER-SEAT AREA**

- The main wiring harness must pass under the central beam of the frame

**TABLE R1**

- The layout of the main wiring harness and of the various branches in the filter box area must be as illustrated in the image



TABLE S - MAIN FUSES AND ABS

1. Fuse "A" (15A)
2. Fuse "B" (15A)
3. Fuse "C" (15A)
4. Fuse "D" (5A)
5. Fuse "E" (5A)
6. Fuse "F" (30A)
7. Fuse "G" (20A)

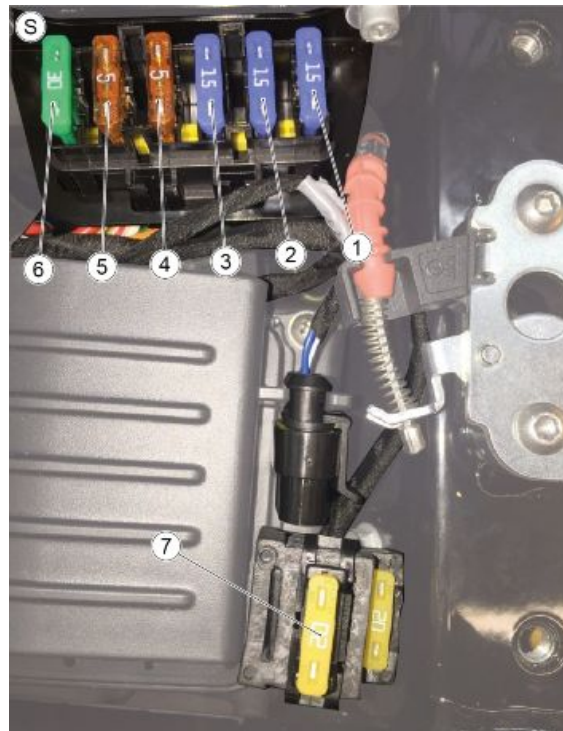
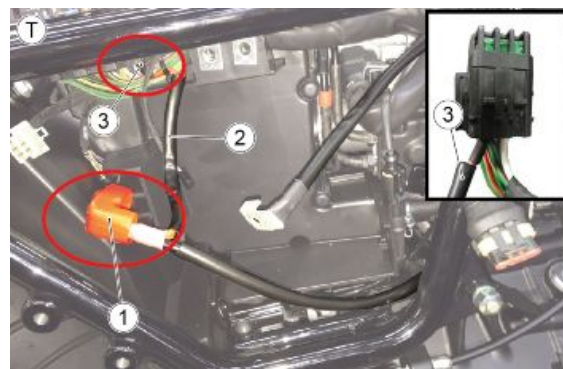


TABLE T - PASSAGE OF THE STARTER MOTOR BATTERY

- The cap of the battery positive (1) must be red
- The cable that goes from the battery positive to the fuse box must be covered with sheath (2) and the terminal must be covered with heat shrink material (3)



INCORRECT SECURING OF THIS COMPONENT MAY CAUSE THE VEHICLE TO CATCH FIRE

TABLE T1

- The motor starter cable must pass over the filter box pipe



TABLE T2

- Check that the starter positive cap is correctly inserted and that the nut is fastened to the prescribed torque



INCORRECT SECURING OF THIS COMPONENT MAY CAUSE THE VEHICLE TO CATCH FIRE

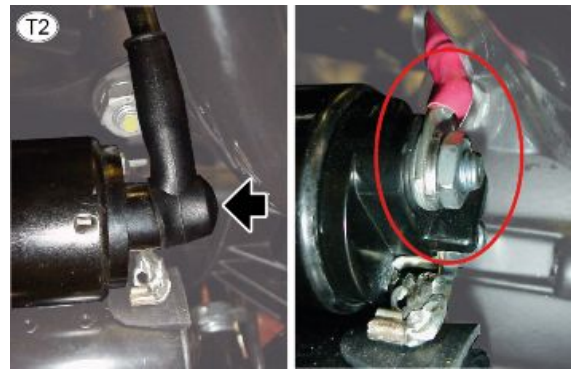


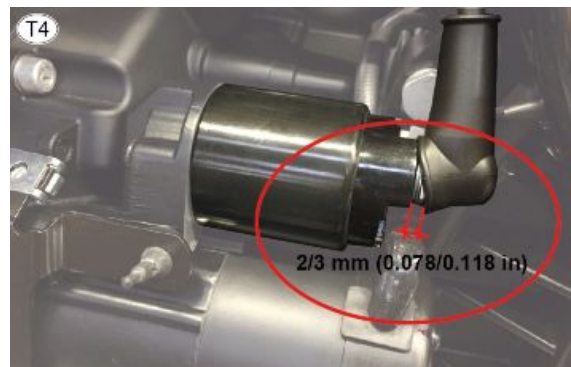
TABLE T3

- Check that the faston is correctly inserted



TABLE T4

- The protection cap may remain outside for maximum 2-3 mm (0.078-0.118 in)



Back side

TABLE A - REAR WHEEL ABS SENSOR ROUTING

- Fasten the rear ABS sensor wiring harness to the brake pipe using one of the cable guides, as indicated

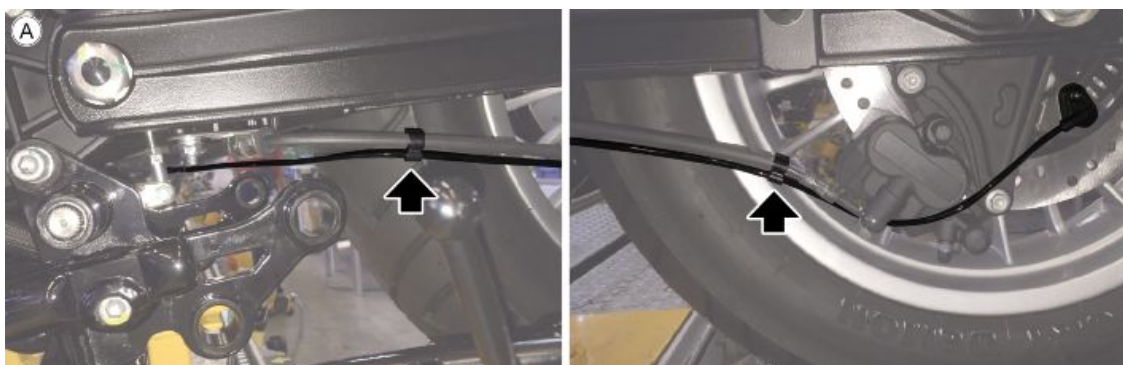


TABLE A1

- fasten the rear ABS sensor wiring harness to the brake pipe, under the swingarm, using one cable guide (1) and a clamp (2)

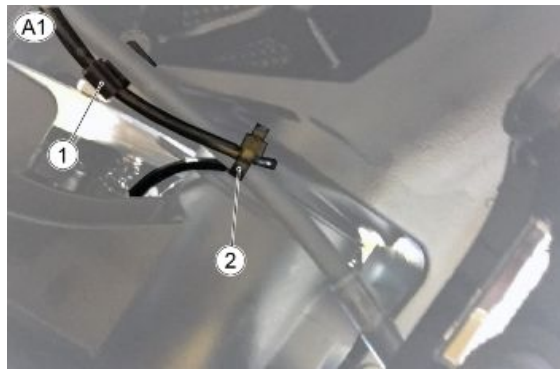


TABLE A2

- Using a clamp, fasten all electric cables



TABLE B - REAR MUDGUARD PRE-FITTING

- Pre-fit the taillight wiring harness on the mudguard and fasten it using the specific flaps on the mudguard



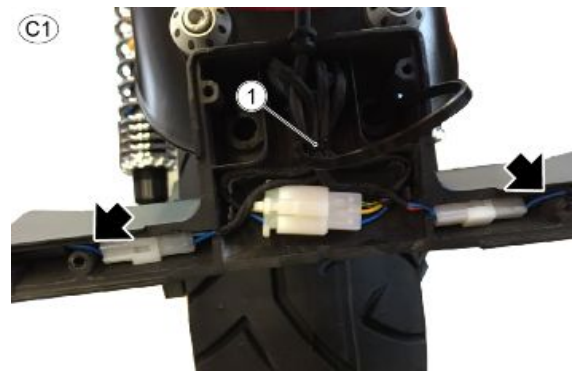
TABLE C - TAILLIGHT CONNECTIONS

- In the marked areas there should be no cables or connectors



TABLE C1

- Using a medium clamp (1), fasten all cables
- Pay attention so that the cables of the turn indicators are inserted in the space above the screws stern

**TABLE C2**

- Check the correct insertion of the rubber ring on the license plate holder

**TABLE D - TAILLIGHT CONNECTION AND "MGPM" FITTING POSITIONING**

- Check the correct connection of the taillight connector



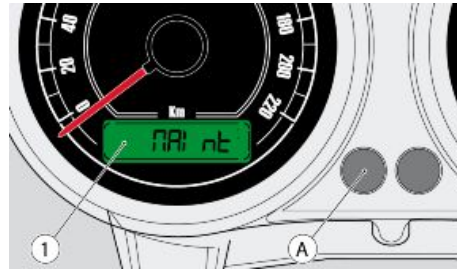
Checks and inspections

Dashboard

Service warning light reset

- The system displays the function as follows:

the word "MAInt" is shown on the left LCD Display (1) after the mileage corresponding to the first servicing or any subsequent servicing is exceeded.



- This is shown only after each start-up for 5 seconds; afterwards, it will shift to the standard view.

To reset Service proceed as follows:

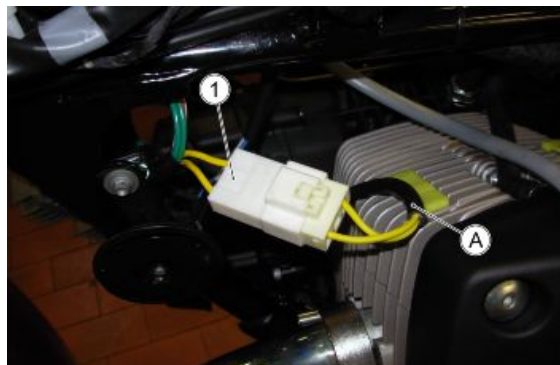
- Hold down the key (A).
- Turn the ignition key to "ON".
- Wait for the Key OFF.

The next time the vehicle is started, the value will be reset and the word "MAInt" will not be displayed until the next mileage for which maintenance is foreseen.

Battery recharge circuit

RECHARGING SYSTEM

- Slightly lift the fuel tank, being careful not to pull the pipes with the relative hooks;
- Remove the connectors from the compartment behind the steering column
- Disconnect the three-way connector (1) (white).

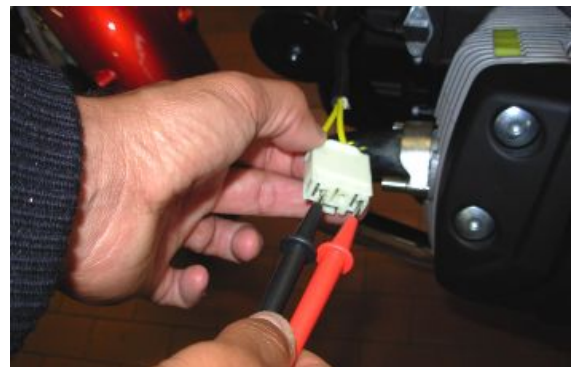
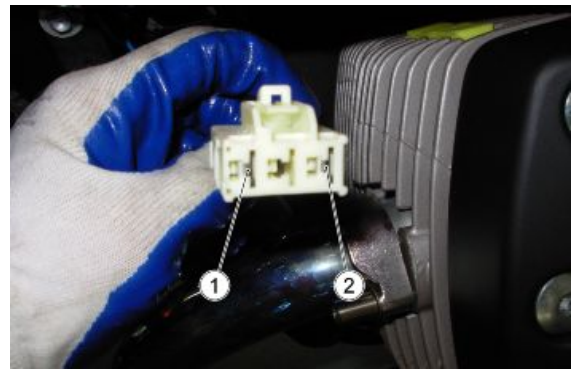


NOTE

THE ENGINE SIDE IS IDENTIFIED WITH THE LETTER "A"

Measurement of resistance (with engine off)

- For a correct detection of the alternator resistance, must be performed an ambient temperature measurement and then a further heat stabilisation with a tester.



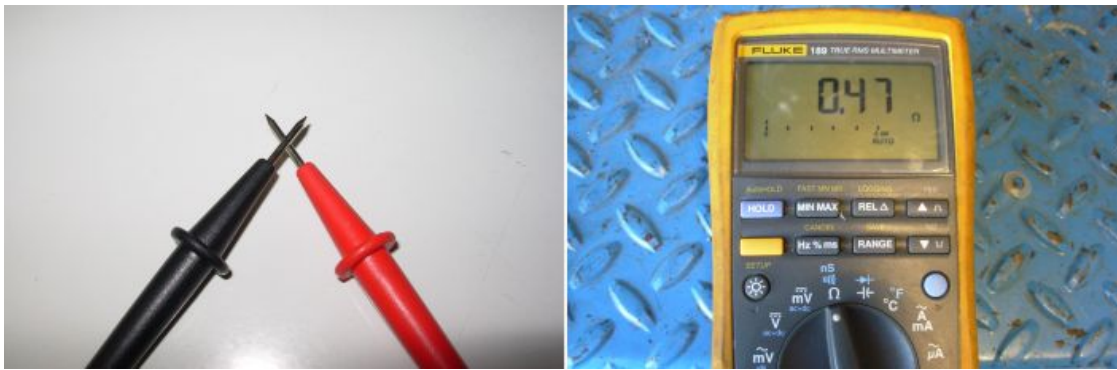
- Take the measurement; The correct value is determined by subtracting the wire resistance of the tester obtained by touching the two pins.

Example:

- Resistance of stage 1 read on the display = 0.67 Ohm



- Resistance of the wires read on the display = 0.47 Ohm



- Effective resistance stage 1 = $0.67 - 0.47 = 0.20$ Ohm

RESISTANCE MEASURE

Winding stage	Ambient temperature (ohm)	Afterwards heat stabilisation (ohm)
Stage 1	0.18 - 0.23	0.20 - 0.25

Zero load voltage

- Disconnect the three-way connector (1);
- For a correct detection of the alternator voltage, a measurement must be carried out using alternatively the 3 engine side connector pins: stage "1" (pin 1-2), stage "2" (pin 1-3), stage "3" (pin 2-3)
- Take the measurements;
- If there is a significant difference between one stage and another (other than 15 V), this means that the alternator is defective and must be replaced.

CAUTION

WITH THE ENGINE HOT THE VALUES RECORDED ARE ON AVERAGE 4-5 V LESS THAN THOSE DETECTED WITH THE ENGINE COLD.

TENSIONE A VUOTO

Giri / min	2000	4000	6000
Vm tensione concatenata Valori di riferimento (V rms)	40 - 45	82 - 87	132 - 138

Short-circuit current

- For a correct detection of the short-circuit current, a connector must be prepared that generates a downstream short circuit between the three alternator cables;
- Start the engine and with an ammeter clamp measure each single cable.



- If there is a significant difference between the measure of the single cables (other than 10 A), this means that the alternator is defective and must be replaced.

CAUTION

WITH THE ENGINE HOT THE VALUES RECORDED ARE ON AVERAGE 2-3 A LESS THAN THOSE DETECTED WITH THE ENGINE COLD.

WARNING

NEVER KEEP THE ENGINE RUNNING FOR MORE THAN ONE MINUTE; FAILURE TO DO SO COULD CAUSE SERIOUS OVERHEATING DAMAGES TO THE MOTORCYCLE CIRCUITS.

COLD SHORT CIRCUIT CURRENT

RPM	2000	4000	6000	8000
RMS DC current (Arms) (average of the 3 stage currents)	26 - 30	20 - 25	30 - 35	30 - 35

Voltage on battery poles with engine speed always between 3000 - 5000 RPM

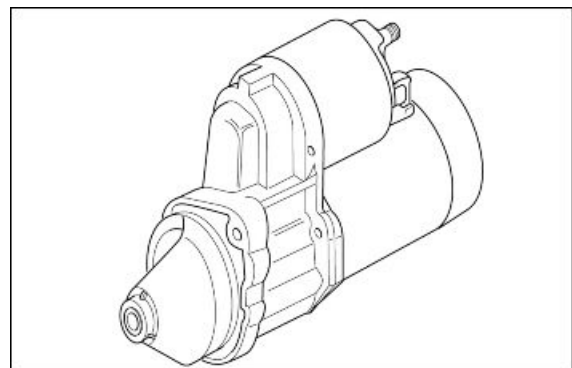
- Start the engine, after about one minute of operating bring the speed to 3000-5000 RPM, then measure with a tester the voltage at the battery poles that must always be between 13V and 15V. Otherwise, if the correct operation of the alternator has already been checked, replace the regulator.

CAUTION

PERFORM THE CHECK DESCRIBED ABOVE WITH A BATTERY IN GOOD CONDITION (START VOLTAGE ABOUT 13V) MAKING SURE THAT THERE ARE NO ELEMENTS IN THE SHORT CIRCUIT.

Start-up system check

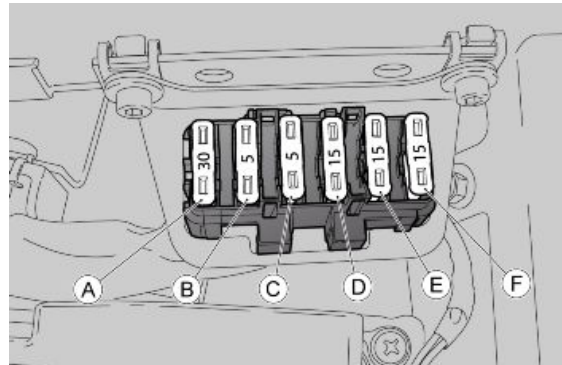
pick-up input about 100 A



Fuses

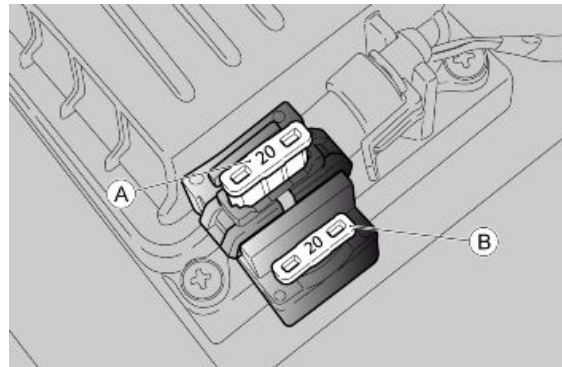
FUSE LOCATION

- A) Main fuse, coil 1 and 2, injector 1 and 2, oxygen sensor 1 and 2 (30 A).
- B) (Battery positive) MIU G3 ECU (5 A).
- C) (Battery positive) Instrument panel, turn indicators, bluedash (5 A).
- D) ECU, engine kill, start relay, instrument panel, injection loads relay (15 A).
- E) Provision for GPS, low beam / high beam, passing, USB, bluedash (15 A).
- F) Brake light, running lights, horn (15 A).



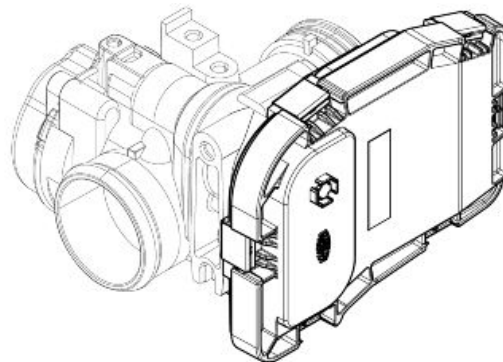
ABS FUSE DISTRIBUTION

- A) ABS Control unit (20 A).
- B) Spare fuses (20 A).



Control unit

Engine control unit Magneti Marelli MIU G3

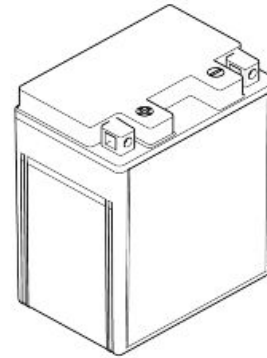


Battery

Characteristic

Battery

12 V - 12 Ah

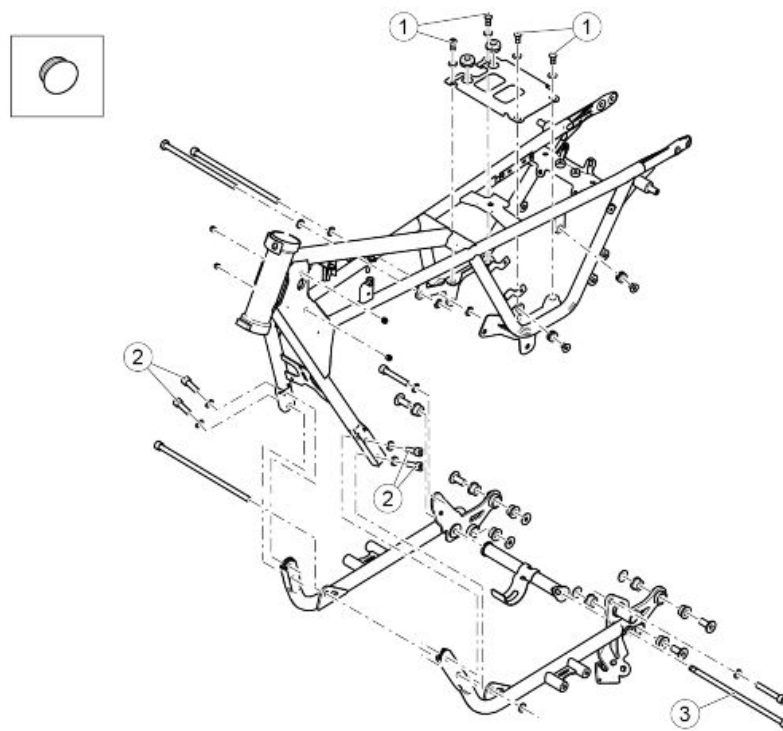


Connectors

INDEX OF TOPICS

ENGINE FROM VEHICLE

ENG VE



CHASSIS

pos.	Description	Type	Quantity	Torque	Notes
1	Battery holder plate fastening screws	M8x20	4	25 Nm (18.44 lb ft)	-
2	Front cradle SHC fixing screws	M10x30	4	50 Nm (36.88 lb ft)	-
3	Pin fastening the stand to the cradles	M10x266	1	50 Nm (36.88 lb ft)	-

Vehicle preparation

- To arrange for the removal of the engine block, you must first remove the saddle, fuel tank, side fairings and the battery
- From the front, secure the vehicle with belts attached to a hoist
- Position a centre stand under the engine sump
- Position an engine support so as not to damage the rubber bellows of the drive shaft

INDEX OF TOPICS

ENGINE

ENG

TO CONSULT THE CHAPTER ABOUT THE ENGINE AND ITS COMPONENTS PLEASE REFER TO THE APPROPRIATE MANUAL:

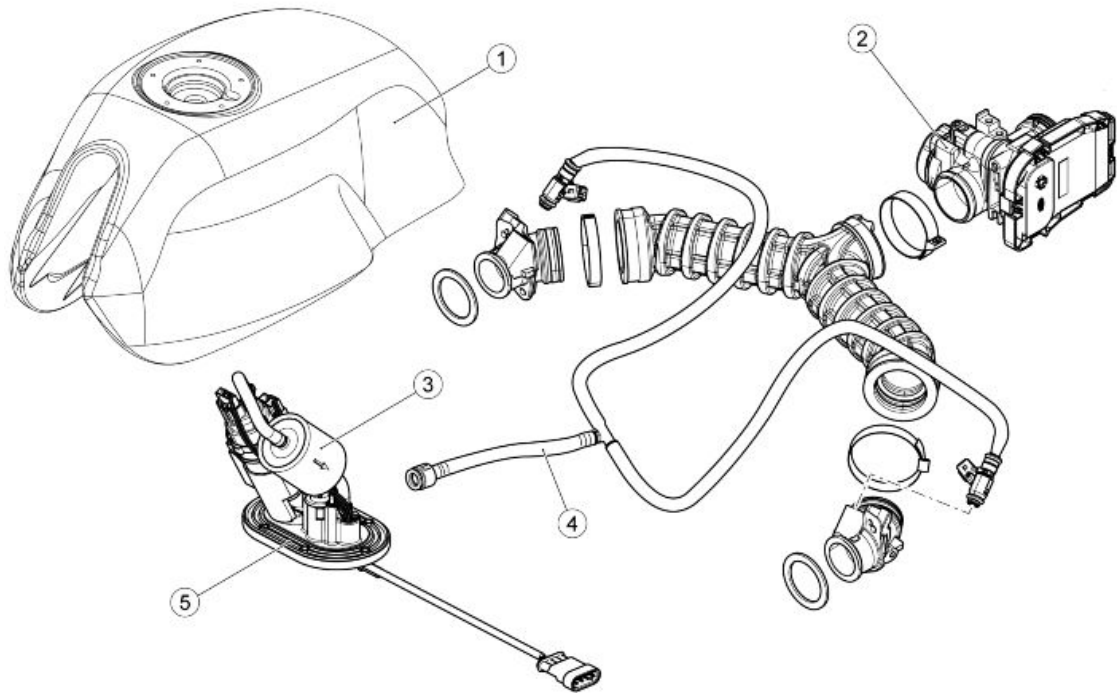
"MSS Engine V750 IE My2012"

INDEX OF TOPICS

POWER SUPPLY

P SUPP

Circuit diagram

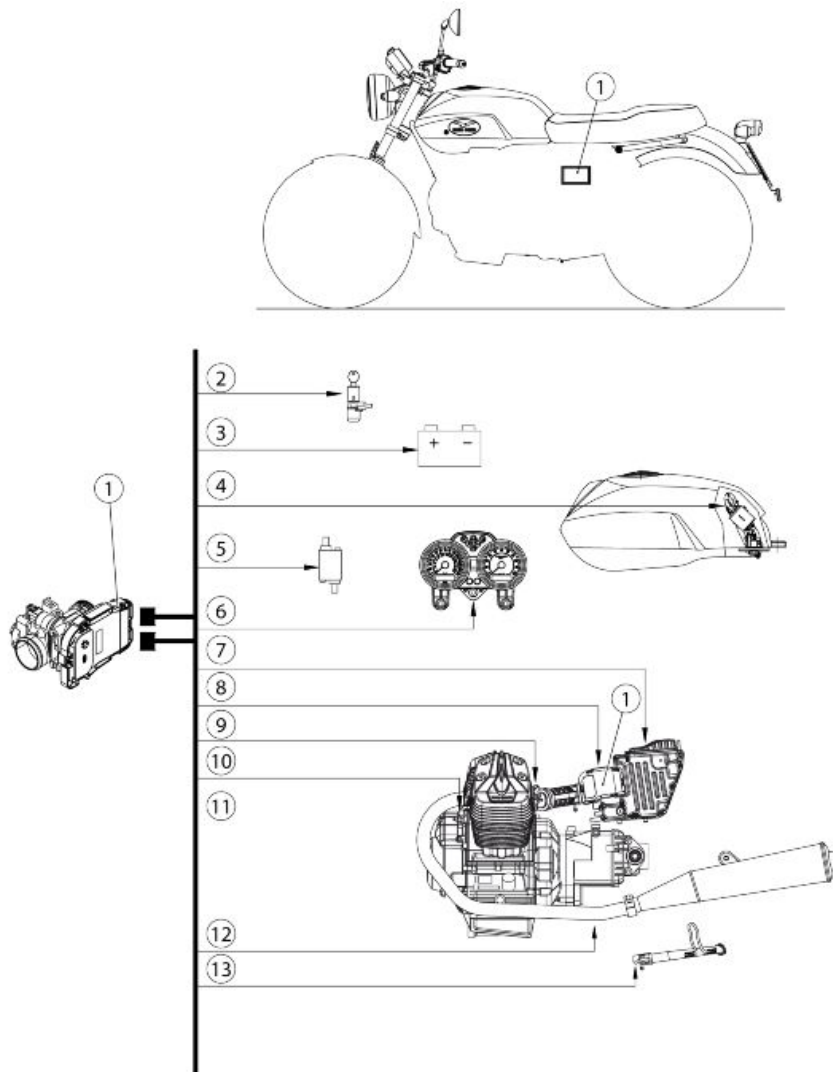


key:

- 1. Fuel tank
- 2. Throttle body
- 3. Fuel filter
- 4. Fuel delivery pipe
- 5. Fuel pump unit

Injection

Diagram

**key:**

1. Control unit position
2. Ignition switch
3. Battery
4. Fuel pump
5. Coils
6. Instrument panel
7. Air temperature sensor
8. Throttle valve position sensor
9. Injectors
10. Crankshaft position sensor
11. Engine temperature sensor
12. Lambda probe

13.Side stand

ECU INFO screen page

This screen page shows general data regarding the control unit, for example software type, mapping, control unit programming date

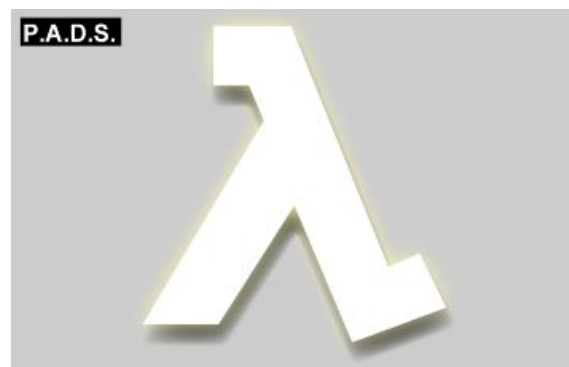


INFO ECU SCREEN PAGE

Specification	Desc./Quantity
Mapping	-

PARAMETERS screen page

This screen page shows the parameters measured by the several sensors (engine revs, engine temperature, etc.) or values set by the control unit (injection time, ignition advance, etc.)



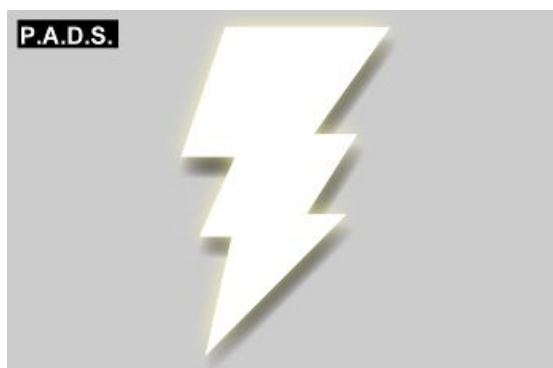
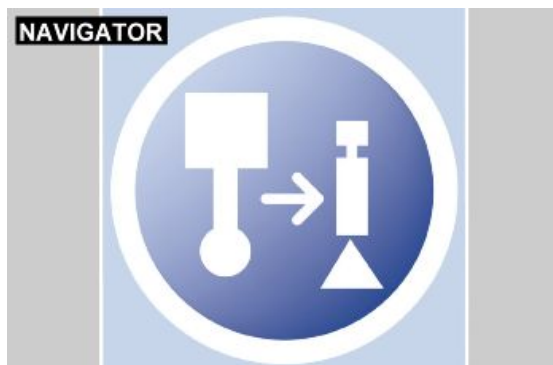
ENGINE PARAMETER READING SCREEN PAGE

Navigator characteristic	P.A.D.S. characteristic	Description / Value
Engine rpm	Engine rpm	Rpm: the minimum value is set by the control unit cannot be adjusted
Entire throttle position	Throttle angle	Rpm: the minimum value is set by the control unit cannot be adjusted
Engine temperature	Engine temperature	°C

Navigator characteristic	P.A.D.S. characteristic	Description / Value
Left lambda probe voltage	Lambda probe voltage 1	100 - 900 mV (indicative values) Signal when energized that the control unit receives from the lambda probe: inversely proportional to the presence of oxygen
Right lambda probe voltage	Lambda probe voltage 2	100 - 900 mV (indicative values) Signal when energized that the control unit receives from the lambda probe: inversely proportional to the presence of oxygen
Left cylinder lambda correction	Lambda correction factor 1	-
Right cylinder lambda correction	Lambda correction factor 2	-
Steps carried out	Steps carried out	Steps carried out of the control unit in minimum control phase
Advance ignition carried out	Advance carried out	Value referring to left cylinder
Advance ignition programmed	Advance programmed	Value referring to left cylinder
Injection time	Injection time	-
Left cylinder adaptive correction	Lambda adaptive gain 1	-
Right cylinder adaptive correction	Lambda adaptive gain 2	-
Atmospheric pressure	Atmospheric pressure	The value is estimated by the control unit
Intake pressure	Intake pressure	Pressure detected in the intake duct
Target idle rpm	Idling target	is a target value for the engine speed at the minimum set by the control unit (with engine warm)
Programmed steps	Programmed steps	Steps corresponding to the reference position of the engine idle
Idle motor equivalent throttle	Stepper equivalent throttle	Expresses the minimum contribution of air in the motor throttle degrees

ACTIVATION screen page

This screen page is used to delete errors in the control unit memory and to activate some systems controlled by the control unit.



DEVICES ACTIVATION

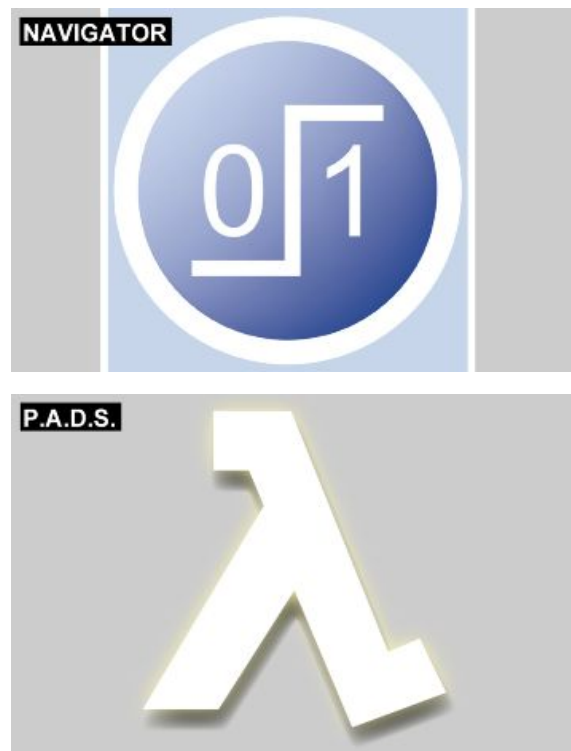
Navigator characteristic	P.A.D.S. characteristic	Description / Value
H.V. coil left cylinder	Coil 1	-
H.V. coil right cylinder	Coil 2	-
Rpm indicator	Rpm indicator	-
Left injector	Injector 1	-
Right injector	Injector 2	-

Navigator characteristic	P.A.D.S. characteristic	Description / Value
Idle motor	Stepper	-
Left lambda probe heater	Lambda probe heater 1	-
Right lambda probe heater	Lambda probe heater 2	-
Headlamp relay	Headlamp relay	-
Fuel pump relay	Fuel pump relay	-
Warning lamp control or EFI icon	General warning light	-
Error clearing	-	-
Reading errors of environmental parameters	-	-
Freezes and saves the parameter values of the states	-	-

Using P.A.D.S. for injection system

STATUS screen page

This screen page shows the status (usually ON/OFF) of the vehicle devices or the operation condition of some vehicle systems (for example, lambda probe functioning status).



DEVICE STATUS

Navigator characteristic	P.A.D.S. characteristic	Navigator Description / Value	P.A.D.S. Description / Value
Lean title (left cylinder)	Lean title cylinder 1	Yes/No	Yes/No
Lean title (right cylinder)	Lean title cylinder 2	Yes/No	Yes/No
Idle motor	Idle motor	Ready for start / Open loop / Closed loop	OK start-up / O.Loop / ClosLoop / Closed
Left cylinder lambda control	Lambda circuit 1	Open loop / Closed loop	Open / Closed / Diagnosis / Error
Right cylinder lambda control	Lambda circuit 2	Open loop / Closed loop	Open / Closed / Diagnosis / Error
Rich title (left cylinder)	Rich title cylinder 1	Yes/No	Yes/No
Rich title (right cylinder)	Rich title cylinder 2	Yes/No	Yes/No
Engine status	Engine status	Undetermined / Power-On and Engine Off/ Key-On and Engine Off/ Engine in rotation / Engine Stalled /	Undetermined / ON/Stop / Key/Stop / Rotat. / Stall / PL course / PL Term / Sync_4t

Navigator characteristic	P.A.D.S. characteristic	Navigator Description / Value	P.A.D.S Description / Value
		Power-Latch in course / Power-Latch finished / Engine in stop phase	
Engine control	-	Synchronized on the 4 stroke cycle / Not synchronized on the 4 stroke cycle	
Throttle	Throttle status	Minimum opening / Partial opening / Maximum opening	Minimum / Partial / FullPot
Start request	Start request	Yes/No	Absent/present
Rpm sensor signals panel	Synchronised panel	Not synchronized / synchronized / Partially synchronized	Partial / NO / YES / Lean / Rich / Rich title/ Error / Lean title
Engine stop button	RUN / OFF switch	Gear enabled / Gear not enabled	RUN / OFF
Side stand	-	Up/Down	
Left lambda probe short term diagnosis	-	Complete / Not complete	
Right lambda probe short term diagnosis	-	Complete / Not complete	
Left lambda probe short term error	-	Yes / No / Not detectable	
Right lambda probe short term error	-	Yes / No / Not detectable	
Minimum motor short term diagnosis	motor.diag min.comp	Complete / Not complete	Complete / Not done
Minimum motor short term error	Idle motor error	Yes / No / Not detectable	Yes/No
Fan relay	Fan relay	Not activated / Activated	OFF / 2 active / 1 active / req. 1 / req. 2
Engine mode	Engine mode	Undetermined/ Start-up / Start-up stabilized / Start-up with deceleration / Start-up with acceleration / Idling compensated for start-up / Engine stable outside idling / Engine idling	Undeterm / Start / Stabil / Start_dec / Start_acc / Min_Comp / Stable / Min / Accel. / Decel. / Cut-Off / RCUT-OFF
Engine mode	Engine mode	Engine in acceleration / Engine in deceleration / Cut-Off /	
Gearbox in neutral	Gear engaged	Yes/No	Yes/No
Clutch	Clutch	Released / Pulled	Released / Pressed
Left lambda probe	-	Operative / Not operative (Error) / Not operative (Rich) / Not operative (Lean) / Not operative (Heater) / Not operative (Start-up) / Not enabled	
Right Lambda probe	-	Operative / Not operative (Error) / Not operative (Rich) / Not operative (Lean) / Not operative (Heater) / Not operative (Start-up) / Not enabled	
Riding Enable	Start-up enabling switch	Yes/No	
-	Stepper motor status	-	OK start-up / O.Loop / ClosLoop
-	Fall sensor	-	Inhibited / Consent / --- / Crack Decel. / Crank Accel. / Crank Minimum / Stabilized / Minimum / Accelerated / Decelerated / CAT-OFF status / CAT-OFF Output
-	Recharge status Enabling Ignition	-	OFF / ON / Kick Down / Close Loop / Diag ShortTerm / Error ShortTerm

ERRORS screen page

This screen page displays any errors detected in the vehicle (ATT) or stored in the control unit (MEM) and you can check that the cancellation of error (STO) has taken place.



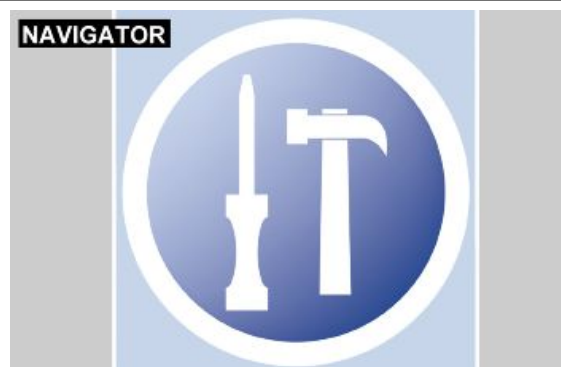
ERRORS DISPLAY

Err or	Navigator characteristic	P.A.D.S. characteristic	Navigator Description / Value	P.A.D.S Description / Value
P0105	Air pressure sensor	Ambient pressure sensor	short circuit to positive / open or short circuit to negative / signal not plausible	Short circuit to positive / Open or short circuit to ground / Signal not plausible
P0110	Air temperature sensor	Air temperature sensor	short circuit or open circuit to positive / short circuit to negative	Open or short circuit to positive / Short circuit to ground
P0115	Engine temperature sensor	Engine temperature sensor	short circuit or open circuit to positive / short circuit to negative	Open or short circuit to positive / Short circuit to ground
P0120	TPS	Throttle position sensor (TPS)	short circuit or open circuit to positive / short circuit to negative	Open or short circuit to positive / Short circuit to ground
P0130	Control of air-fuel ratio / Left lambda probe	Lambda probe signal (Bank 1)	short circuit to positive / open circuit, short circuit to negative or excessively lean carburation / signal not plausible for title correction	Short circuit to positive / Open or short circuit to ground / Signal not plausible
P0135	Left lambda probe heater	Lambda heater circ. (Bank 1)	short circuit to positive/ short circuit to negative / open circuit	Short circuit to positive / Short circuit to ground / Open circuit
P0136	Control of air-fuel ratio / Right lambda probe	Lambda probe signal (Bank 2)	short circuit to positive / open circuit, short circuit to negative or excessively lean carburation / signal not plausible for title correction	Short circuit to positive / Open or short circuit to ground / Signal not plausible
P0141	Right lambda probe heater	Lambda heater circ. (Bank 2)	short circuit to positive/ short circuit to negative / open circuit	Short circuit to positive / Short circuit to ground / Open circuit
P0169	Starter button	Starter signal	shorted to positive	Short circuit to positive
P0170	Starter	Starter diagnosis (relay)	TBD	Short circuit to positive / Open circuit to ground

Err or	Navigator characteristic	P.A.D.S. characteristic	Navigator Description / Value	P.A.D.S Description / Value
P0201	Left cylinder injector	Injector circuit cylinder 1	short circuit to positive/ short circuit to negative / open circuit	Short circuit to positive / Short circuit to ground / Open circuit
P0202	Right cylinder injector	Injector circuit cylinder 2	short circuit to positive/ short circuit to negative / open circuit	Short circuit to positive / Short circuit to ground / Open circuit
P0230	Fuel pump relay	Fuel pump relay control circuit	short circuit to positive/ short circuit to negative / open circuit	Short circuit to positive / Short circuit to ground / Open circuit
P0335	Engine speed sensor (electric)	Engine speed sensor	open circuit	Open Circuit
P0336	Engine speed sensor (functional)	Engine speed sensor (Plausibility)	signal not valid	Signal not valid
P0351	H.V. coil	No. 1 coil circuit	short circuit to positive / short circuit or open circuit to negative	Short circuit to positive / Short circuit or open circuit to ground
P0352	H.V. coil	No. 2 coil circuit	short circuit to positive / short circuit or open circuit to negative	Short circuit to positive / Short circuit or open circuit to ground
P0505	Idle control	Idle control (Stepper motor)	short circuit to positive/ short circuit to negative / open circuit / overpressure	Short circuit to positive / Short circuit to ground / Open circuit / Overpressure above specifications
P0530	Light relay	Headlamp relay command	short circuit to positive/ short circuit to negative / open circuit	Short circuit to positive / Short circuit to ground / Open circuit
P0560	Battery voltage	Battery voltage	above maximum threshold / below minimum threshold	Voltage exceeds maximum limit
P0601	Control unit	EEPROM Error (emul. Flash)	EEPROM error	Internal failure to ECU
P0604	Control unit	RAM error	RAM error	Internal failure to ECU
P0605	Control unit	ROM error (Flash)	ROM error (Flash)	Internal failure to ECU
P0606	Control unit	Microprocessor error	Microprocessor error	Internal failure to ECU
P0650	Warning lamp	Warning Lamp Command	short circuit to positive/ short circuit to negative / open circuit	Short circuit to positive / Short circuit to ground / Open circuit

SETTINGS screen page

This screen page is used to adjust some control unit parameters.





ADJUSTABLE PARAMETERS

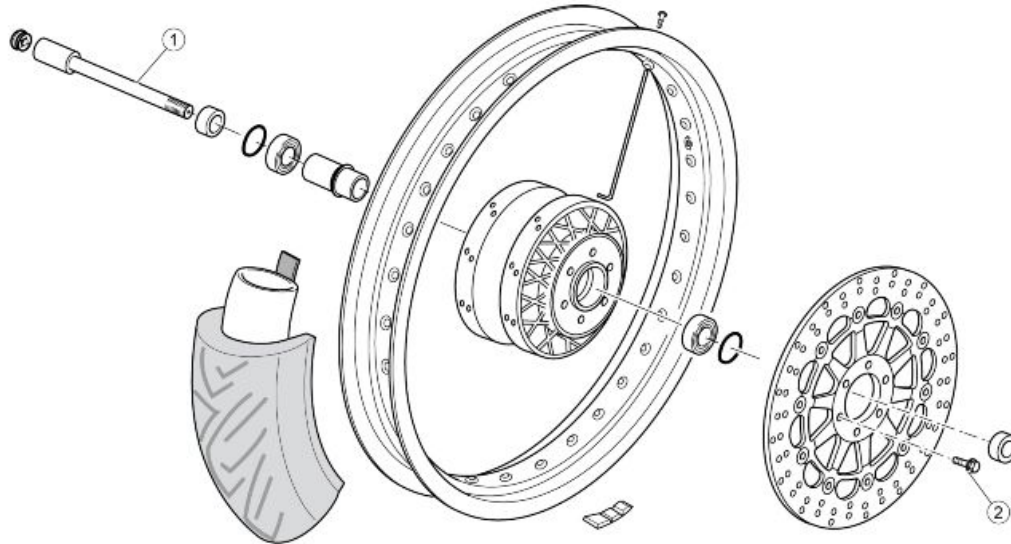
Navigator characteristic	P.A.D.S. characteristic	Description / Value
Throttle position self-acquisition	TPS reset	-
Saved data file download	Mem. data download (Download + Clearing)	-
Clearing memorized data	Mem. data download (Download + Clearing)	-
Self-adjustable parameters reset	Self-adjustable parameters reset	-

INDEX OF TOPICS

SSUSPENSIONS

SUSP

Front

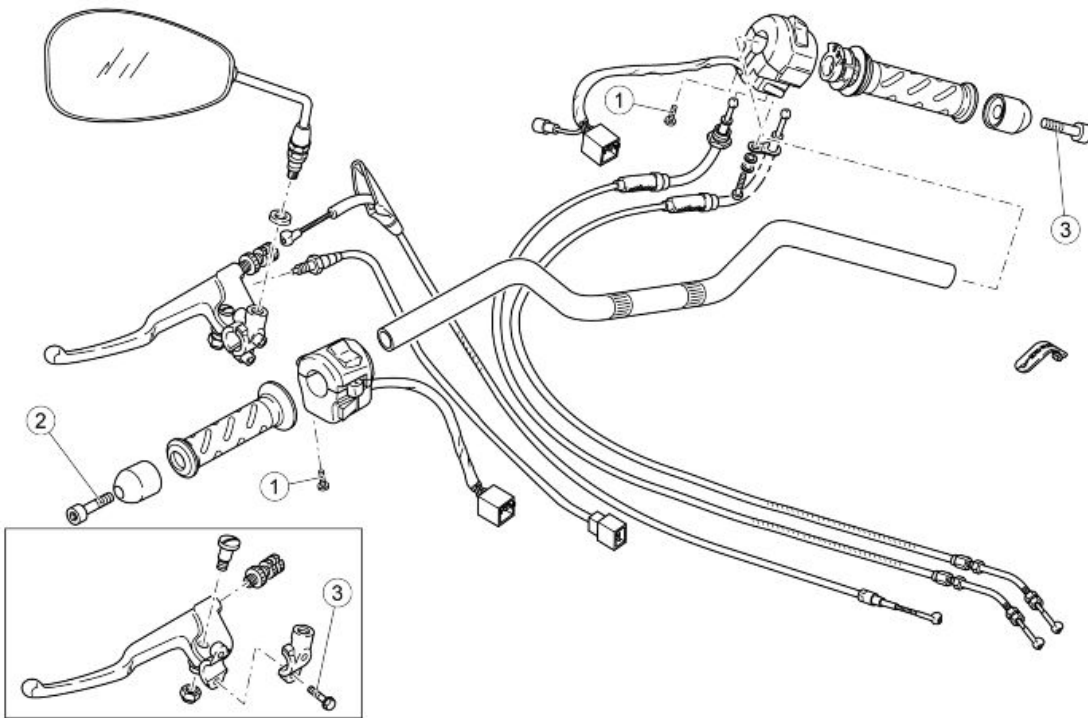


FRONT WHEEL

pos.	Description	Type	Quantity	Torque	Notes
1	Front wheel axle	M18x1.5	1	80 Nm (59.00 lb ft)	-
2	Front brake disc fixing screw	M8x20	6	25 Nm (18.44 lb ft)	Loctite 243

Handlebar

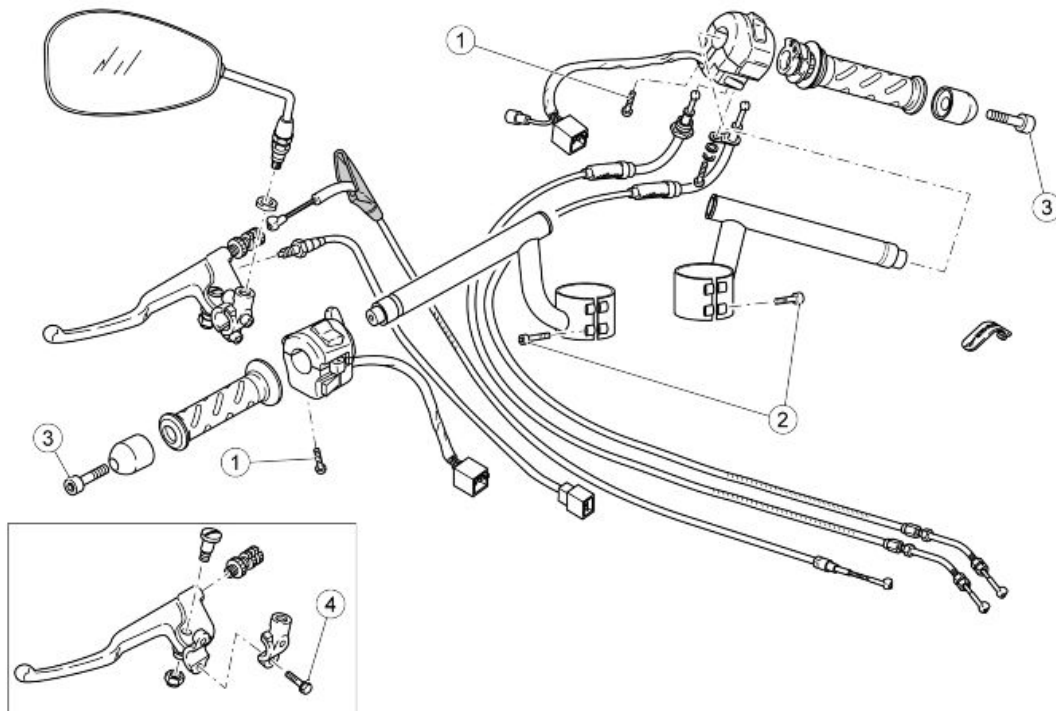
(V7 SPECIAL / V7 STONE)



HANDLEBAR AND CONTROLS

Pos.	Description	Type	Quantity	Torque	Notes
1	Switch fastener screw	SWP 5	1+1	1.5 Nm (1.11 lb ft)	-
2	Counterweight fixing screw	M6	2	10 Nm (7.38 lb ft)	Loctite 243
3	Screw fastening the clutch control U-bolt to the semi-handlebar	M6x25	2	10 Nm (7.37 lb ft)	-

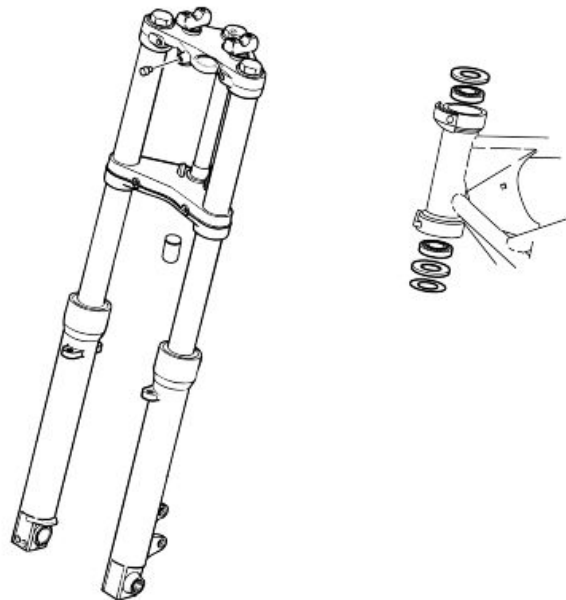
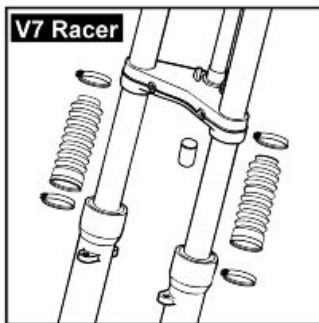
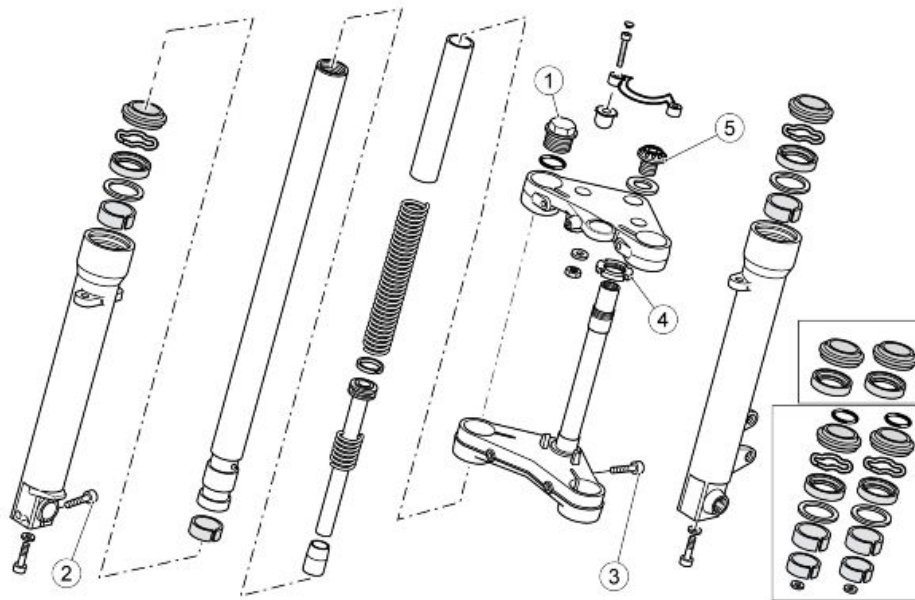
(V7 RACER)



HANDLEBAR AND CONTROLS

Pos.	Description	Type	Quantity	Torque	Notes
1	Switch fastener screw	M5	1+1	1.5 Nm (1.11 lb ft)	Tighten using a 1-2-1 sequence
2	Semi-handlebar fixing screw	M6x25	4	10 Nm (7.37 lb ft)	Tighten using a 1-2-1 sequence
3	Counterweight fixing screw	M6	2	10 Nm (7.37 lb ft)	Loctite 243
4	Screw fastening the clutch control U-bolt to the semi-handlebar	M6x25	2	10 Nm (7.37 lb ft)	Tighten using a 1-2-1 sequence

Front fork

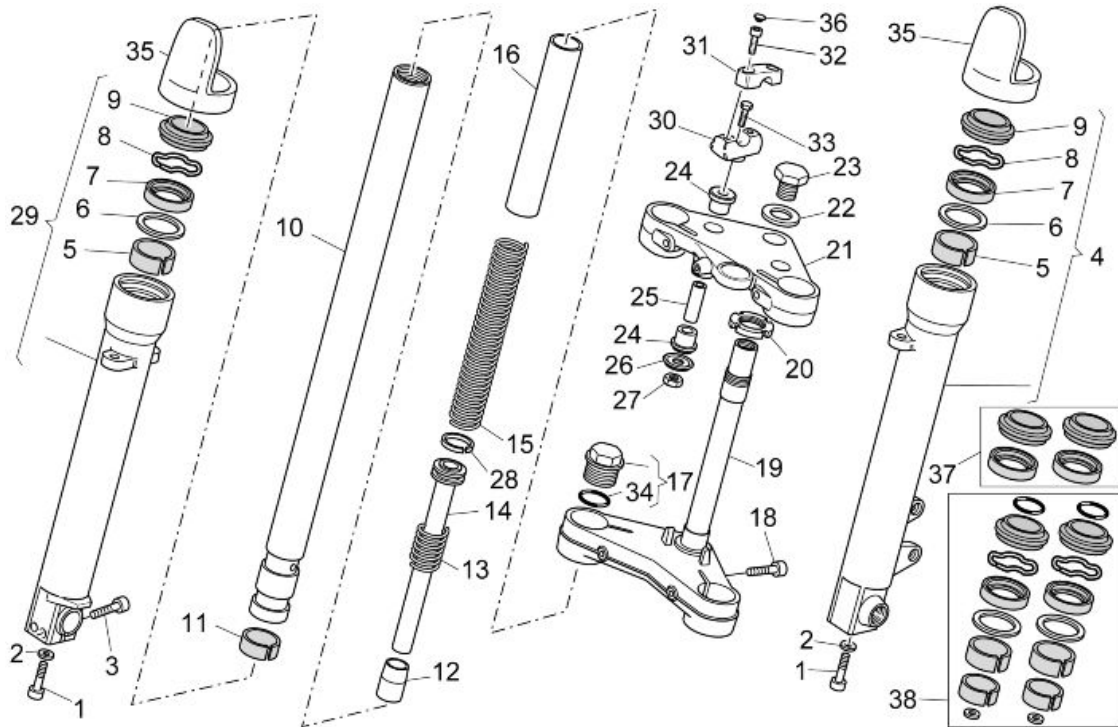


FRONT SUSPENSION - STEERING

pos.	Description	Type	Quantity	Torque	Notes
1	Stanchion cap	-	2	50 Nm (36.88 lbf ft)	-
2	Screw fixing wheel axle to right fork leg	M6x30	2	10 Nm (7.37 lbf ft)	Tighten using a 1-2-1 sequence
3	Screw fixing stanchions to upper and lower plate	M10x40	4	50 Nm (36.88 lbf ft)	-
4	Headstock ring nut	M25x1	1	7 Nm (5.16 lbf ft)	The fork must fall to one side by itself

pos.	Description	Type	Quantity	Torque	Notes
5	Headstock bushing	M23x1	1	50 Nm (36.88 lbf ft)	-

Diagram



Key:

1. Screw
2. Washer
3. Screw
4. Complete left sleeve
5. Upper bushing
6. Washer
7. Sealing ring
8. Snap ring
9. Dust guard
10. Stem
11. Lower bushing
12. Buffer
13. Counter spring
14. Complete pumping member
15. Spring
16. Pipe
17. Complete cap

- 18.Screw
- 19.Base with headstock
- 20.Ring nut
- 21.Fork upper plate
- 22.Washer
- 23.Nut
- 24.Rubber ring
- 25.Spacer
- 26.Cap
- 27.Nut
- 28.Ring
- 29.Complete right sleeve
- 30.Lower U-bolt
- 31.Upper U-bolt
- 32.Screw
- 33.Screw
- 34.O-ring
- 35.Stem protection
- 36.Chrome-plated cap
- 37.Gasket kit
- 38.Oil seal kit

Removing the fork legs

The vehicle is equipped with a non adjustable fork. The operations described below are valid for both stanchions.

CAUTION

DURING THE OPERATIONS DESCRIBED BELOW, THE STANCHIONS AND THEIR INTERNAL COMPONENTS SHOULD BE TIGHTENED ON A VICE. MAKE SURE NOT TO DAMAGE THEM BY OVERTIGHTENING; ALWAYS USE ALUMINIUM JAW CAPS

- Remove the front wheel.
- Remove the front mudguard.



- Undo and remove the two screws and collect the washers.



- Move the instrument panel forwards.

- Undo the upper sealing screw.



- Undo the lower sealing screw.



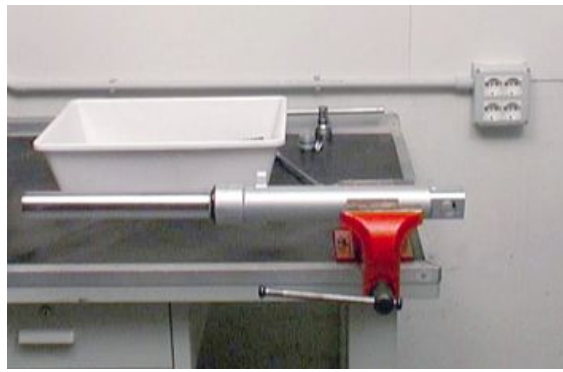
- Slide off the stem downwards by turning it slightly first in one direction then to the opposite direction.

Draining oil

To drain out the oil follow these steps.

- Remove the stanchion.

- Tighten the removed stanchion in a vice fitted with aluminium jaw caps in order to avoid damaging them.



- Unscrew the upper closing cap. Pay attention to the possible thrust that the spring can cause to the loosened cap.



- Be careful not to damage the O-Ring during extraction.
- Press the bearing tube inside the wheel holder fork leg.
- Remove the preload tube and the spring.



- Drain out all the oil inside the stanchion.

NOTE

FOR EASY DRAINAGE OF THE OIL INSIDE THE PISTON ROD, PRESS THE STANCHION IN THE WHEEL HOLDER SLEEVE TO PUMP OIL OUT.



- Carefully check each part of the stanchion and make sure that there are no damaged elements.
- If there are no damaged or worn elements, refit the stanchion; otherwise, replace the damaged elements.

NOTE

FOR EASY DRAINAGE OF THE OIL INSIDE THE PISTON ROD, PRESS THE STANCHION IN THE WHEEL HOLDER SLEEVE TO PUMP OIL OUT.



Disassembling the fork

- Drain all the oil from the stem.
- Block the wheel holder fork leg on the vice.
- Undo the bottom screw and remove it with the corresponding gasket.



- Remove the dust scraper using a screwdriver as a lever.

CAUTION

BE CAREFUL NOT TO DAMAGE THE FORK LEG RIM AND THE DUST SCRAPER.



- Slide the dust scraper off and upwards.



- Remove the locking ring inside the fork leg using a thin screwdriver.

CAUTION

BE CAREFUL NOT TO DAMAGE THE FORK LEG RIM.



- Slide off the bearing tube from the wheel holder fork leg together with the sealing ring, the cap, the upper bushing and lower bushings.

NOTE

WHEN REMOVING THE PIPE FROM THE WHEEL HOLDER FORK LEG SOME PARTS MAY REMAIN INSIDE THE FORK LEG. IF THIS OCCURS, THESE PARTS MUST BE REMOVED AFTERWARDS, BEING CAREFUL NOT TO DAMAGE THE FORK LEG RIM AND THE UPPER BUSHING SEAT



Checking the components

- Check every component removed from the fork leg, specially: the sealing ring and the dust guard as they are elements that guarantee sealing; replace them if some of them are damaged.
- Check the bushing on the bearing tube; remove it and replace it if damaged or worn.
- Slide off the pumping member unit from the holding tube; if it is damaged, replace the counter spring and the ring.



Reassembling the fork

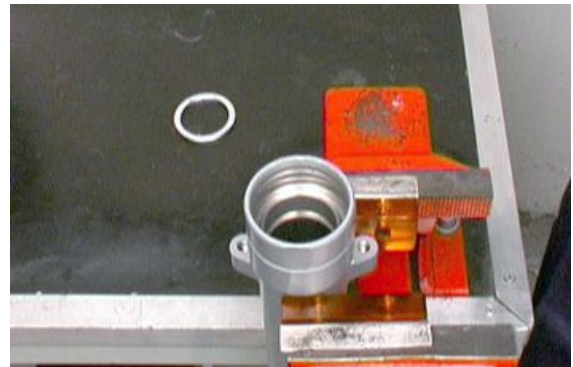
CAUTION

ALL COMPONENTS MUST BE CAREFULLY WASHED AND DRIED WITH COMPRESSED AIR BEFORE REFITTING.

- Carry out any necessary service operation.
- Insert the pumping member unit with the counter spring and the ring in the bearing tube.



- Check that the upper guide bushing is fitted on the wheel holder fork leg.



- Insert the lower sliding bushing in its seat on the bearing tube.



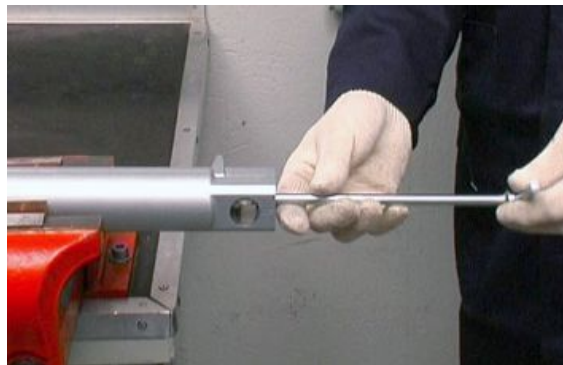
- Reassemble the bearing tube in the wheel holder fork leg.



- Insert the bearing tube in the wheel holder and push it until it stops.



- Screw the bottom screw and tighten it to the prescribed torque.



- Insert the cap and the well-lubricated sealing ring on the bearing tube.
- Use a suitable inserting tool to push the sealing ring in the fork leg until it stops.



- Fit the locking ring.

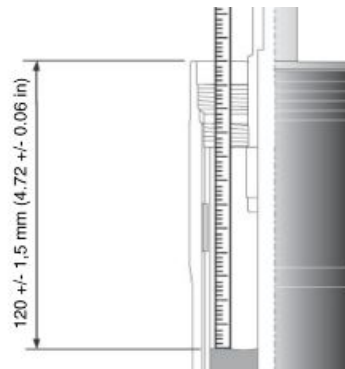


- Fit the dust scraper.
- Pour oil into the bearing tube so that it also fills the internal grooves of the pumping member rod.
- Pump with the bearing tube, making sure the oil has completely filled the pumping member rod.
- Introduce the spring and the preload tube.
- Place the cap on the bearing tube, taking care not to damage the O-ring. Then, tighten the cap to the prescribed torque.



Filling oil

- Place the sleeve upright in a vice fitted with protection jaws.
- Compress the sleeve in the stanchion.
- Pour part of the fork oil into the sleeve.
- Wait some minutes until the oil fills all the ducts.
- Pour the remaining oil.
- Pump out oil a few times.
- Measure the air gap between the oil level and the rim.



THE SLEEVE MUST BE PERFECTLY UPRIGHT IN ORDER TO MEASURE THE CORRECT OIL LEVEL. THE OIL LEVEL MUST BE THE SAME IN BOTH STANCHIONS.

Characteristic

Oil level (from sleeve rim, without the spring and with stem at end of stroke)

120 +/- 1.5 mm (4.72 +/- 0.06 in)

- Introduce the spring and the preload tube.



- Place the cap on the bearing tube, taking care not to damage the O-ring.



- Then, tighten the cap to the prescribed torque.



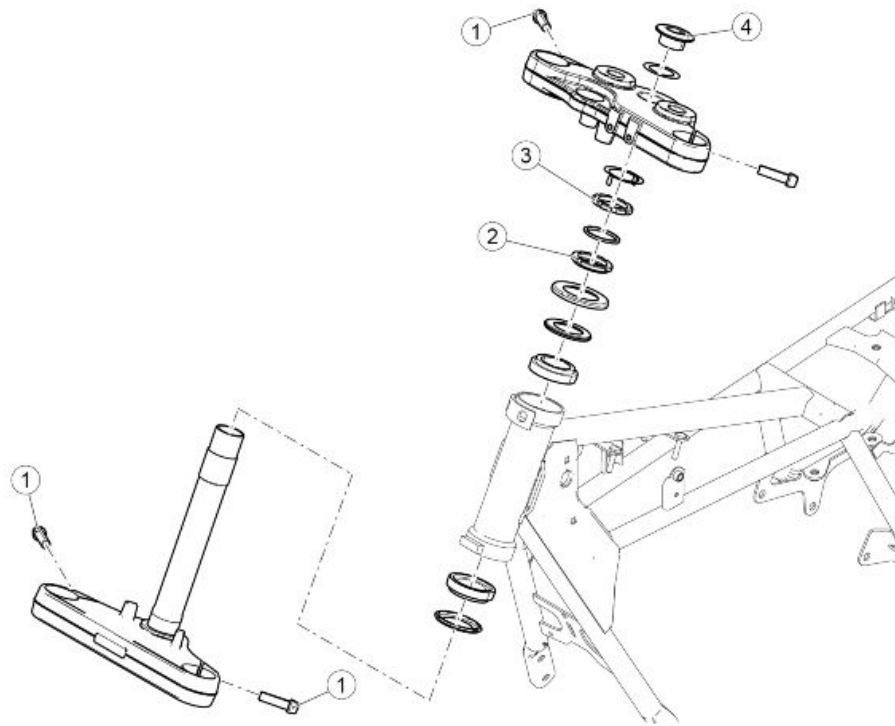
Installing the fork legs

- Insert the stem on the vehicle going through the lower plate and the upper plate.
- Tighten the screws to the prescribed torque.



Steering bearing

Tightening torque



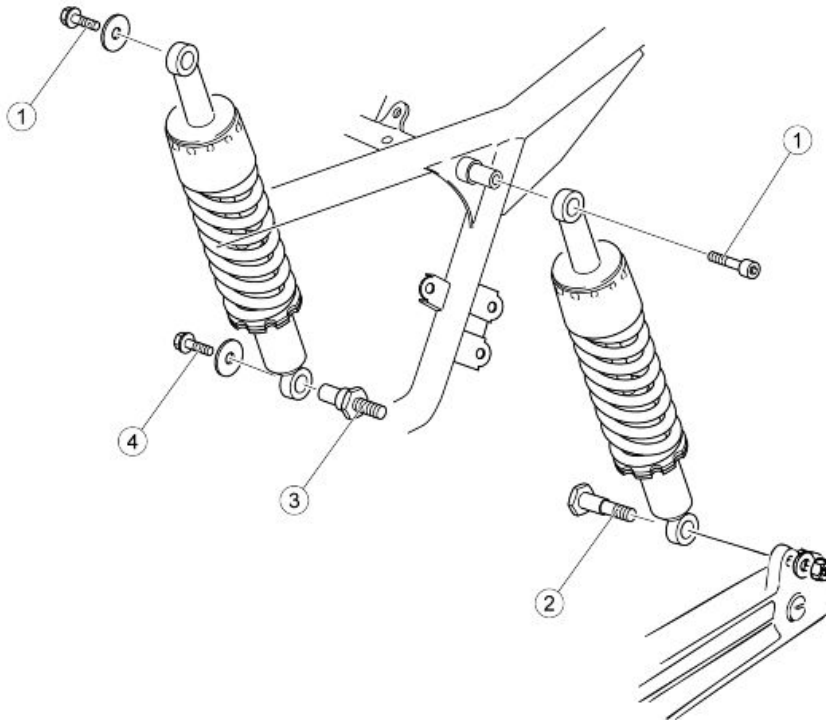
STEERING

pos.	Description	Type	Quantity	Torque	Notes
1	Screw fixing stanchions to upper and lower plate	M10x40	4	25 Nm (18.44 lb ft)	-
2	Steering headstock ring nut (pre-tightening)	-	1	60 Nm (44.25 lb ft)	-
2	Steering headstock ring nut (tightening)	-	1	50 +/- 5 Nm (36.88 +/- 3.69 lb ft)	-
3	Headstock counter ring nut	-	1	-	Screw until obtaining contact with the rubber washer
4	Headstock bushing	-	1	100 Nm (73.76 lb ft)	-

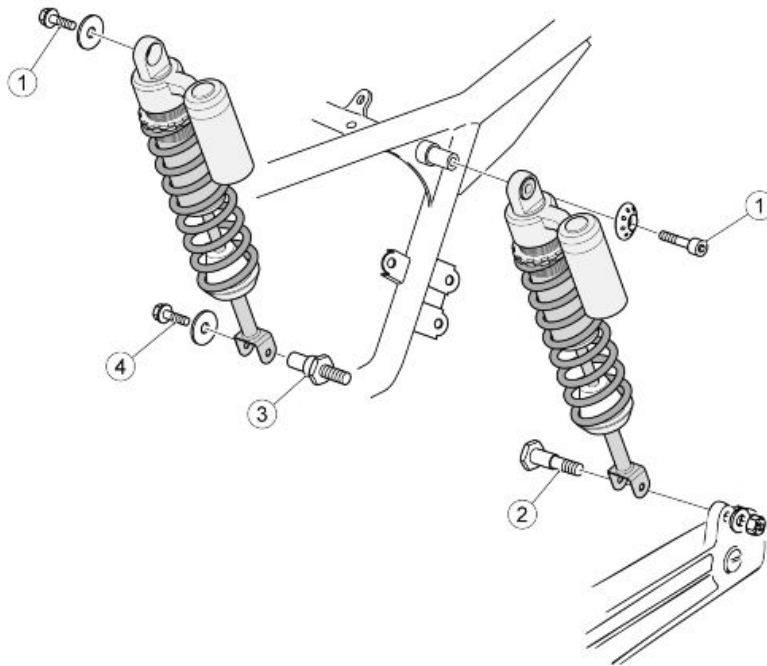
Rear

Shock absorbers

(V7 SPECIAL / V7 STONE)



(V7 RACER)

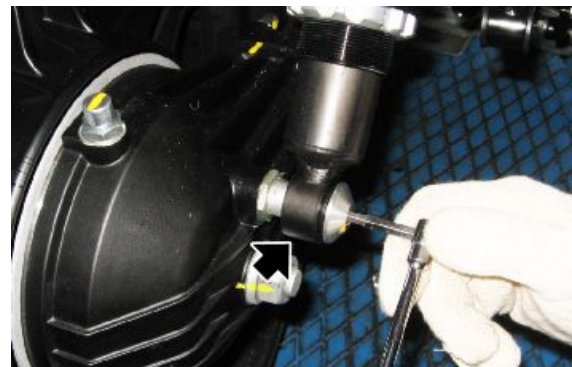


REAR SUSPENSION

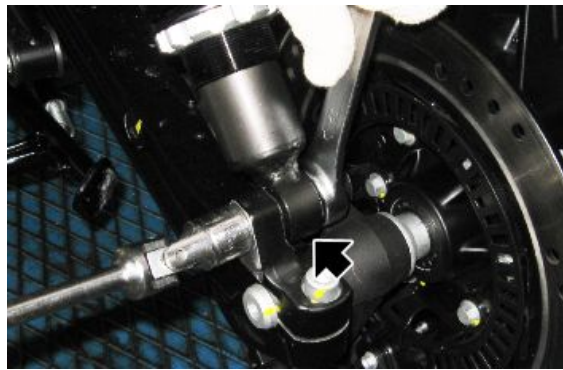
pos.	Description	Type	Quantity	Torque	Notes
1	Upper screw fastening shock absorber to frame	M6x35	2	10 Nm (7.38 lb ft)	Loctite 243
2	Lower pin fastening left shock absorber to swingarm	M10x1.5	1	35 Nm (25.81 lb ft)	
3	Stud bolt fixing right shock absorber to rear box	M12x1.5	1	35 Nm (25.81 lb ft)	-
4	Screw fastening right shock absorber to stud bolt	M6x16	1	10 Nm (7.37 lbf ft)	Loctite 243

Removing

- Remove the screw fixing the right-hand rear right shock absorber and pull it from the pin on the drive shaft



- Remove the screw and the relative nut fixing the left rear shock absorber



- Unscrew and remove the upper screws;
- Remove the shock absorbers.



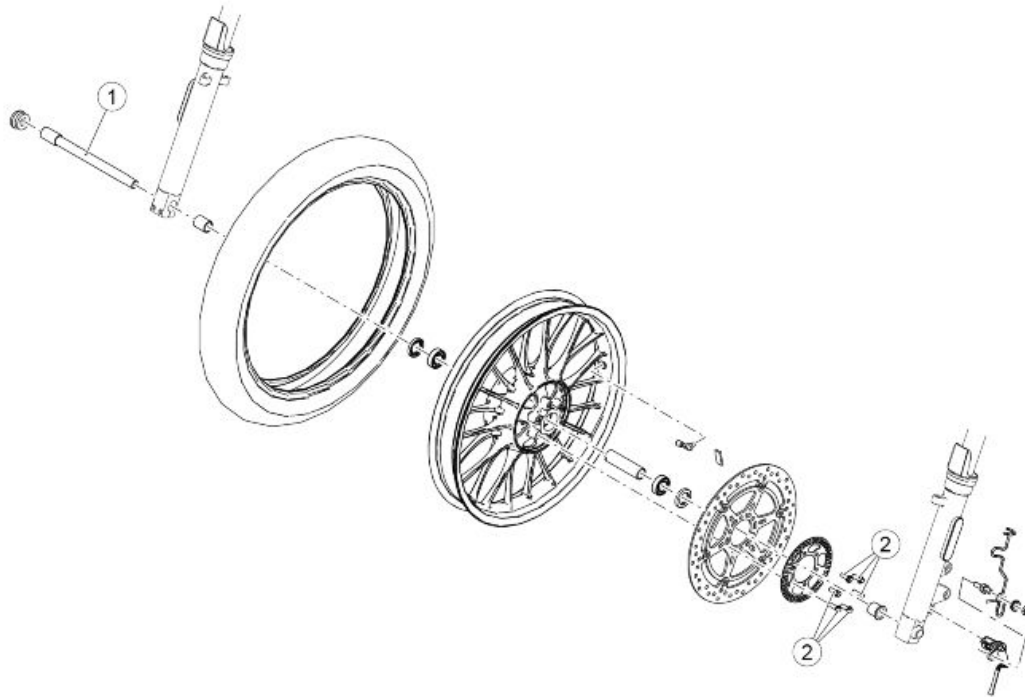
INDEX OF TOPICS

CHASSIS

CHAS

Wheels

Front wheel



FRONT WHEEL

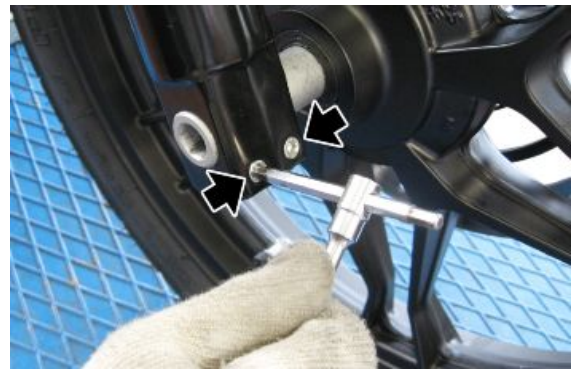
pos.	Description	Type	Quantity	Torque	Notes
1	Front wheel axle	M18	1	80 Nm (59.00 lb ft)	-
2	Phonic wheel/brake disc fastening screws	M8x18	6	25 Nm (18.44 lb ft)	Loct. 243

Removal

- Place the vehicle on a stable support so that the front wheel does not touch the ground;
- Remove the brake calliper without disconnecting the oil pipes;
- Working on the right side of the motorcycle, remove the cap from the pin;



- Loosen the two wheel pin locking screws;



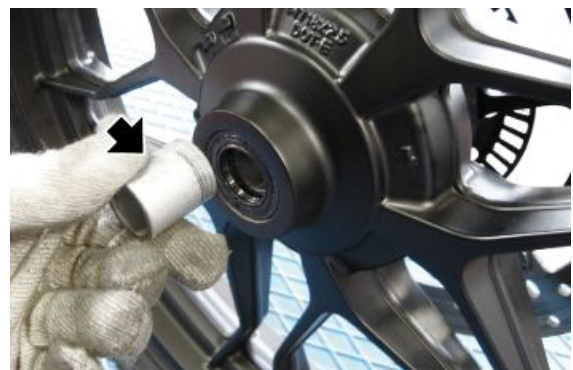
- Unscrew and remove the wheel pin;



- Working on the opposite side, remove the left spacer;

NOTE

DURING REFITTING, PAY ATTENTION TO THE CORRECT POSITIONING OF THE SPACER WHICH MUST BE INSERTED IN THE DUST SEAL UNTIL IT REACHES THE BEARING



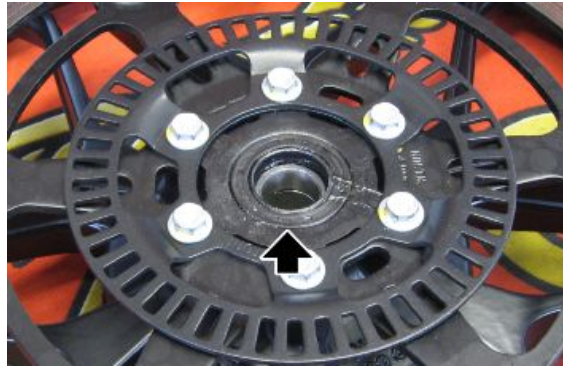
- Working on the opposite side, remove the left spacer;

NOTE

DURING REFITTING, PAY ATTENTION TO THE CORRECT POSITIONING OF THE SPACER WHICH MUST BE INSERTED IN THE DUST SEAL UNTIL IT REACHES THE BEARING

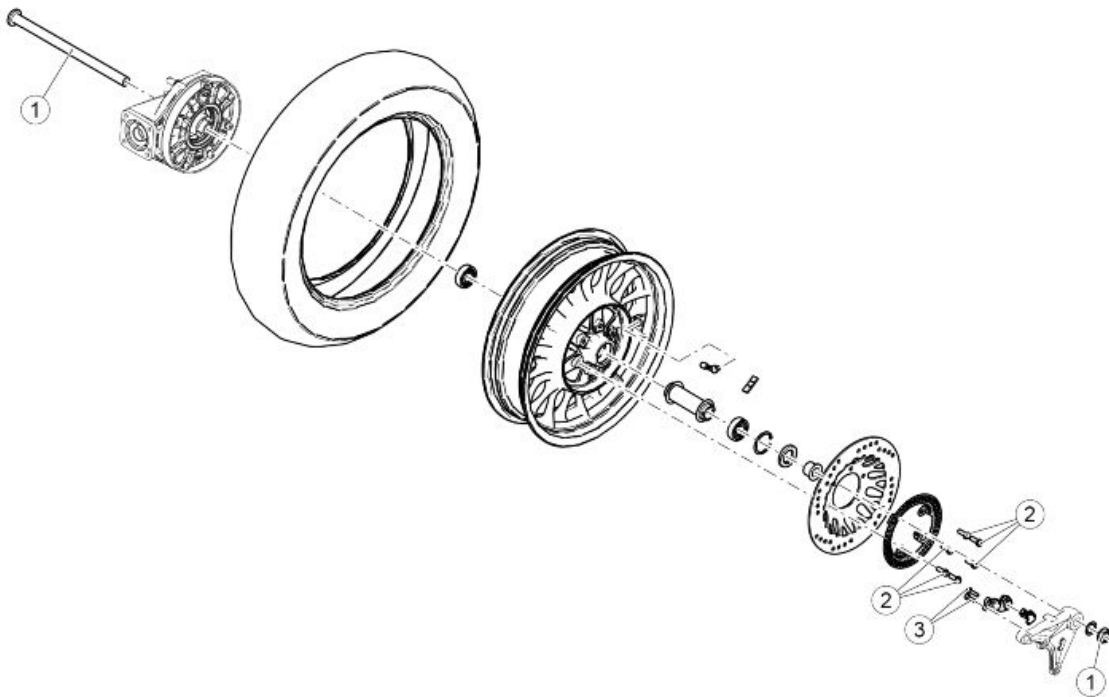


- Remove the dust seal from both sides



- Using a generic bearing extractor remove the bearings from both sides

Rear wheel



REAR WHEEL

pos.	Description	Type	Quantity	Torque	Notes
1	Rear wheel axle fixing nut	M20	1	120 Nm (88.51 lb ft)	-
2	Flanges TE screws fastening phonic wheel and brake disc	M8x22	6	25 Nm (18.44 lb ft)	Loct. 243
3	SHC screws fastening ABS sensor support	M6x12	2	10 Nm (7.38 lb ft)	-

Rimozione

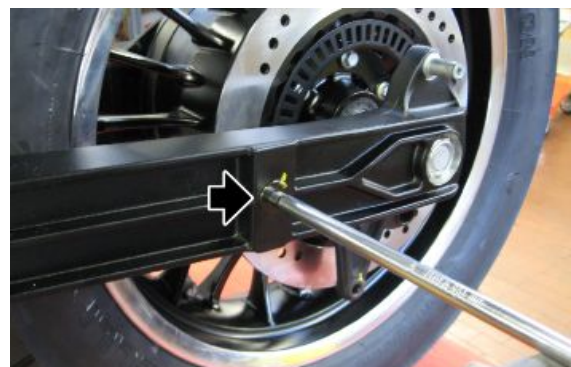
- Remove the screw fixing the right-hand rear right shock absorber and pull it from the pin on the drive shaft



- Remove the screw fixing the left-hand rear shock absorber and remove it from the pin



- Using a jack, lift the rear of the motorcycle.
- Unscrew the rear fixing screw of the rear brake calliper support



- Unscrew the wheel axle nut, making sure to take the washer from the left side and pull the pin itself from the right side.



- Remove the rear brake calliper support



- Collect the spacer

NOTE

DURING REFITTING, PAY ATTENTION TO THE CORRECT POSITIONING OF THE SPACER WHICH MUST BE INSERTED IN THE DUST SEAL UNTIL IT REACHES THE BEARING



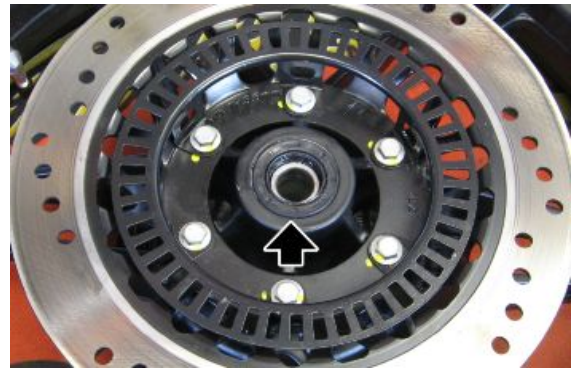
- Remove the rear wheel



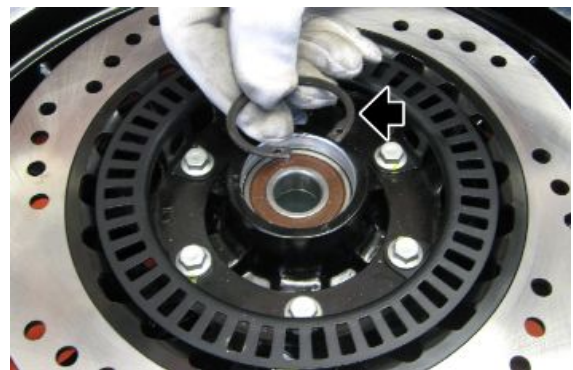
- Remove and if necessary replace the six flexible couplings



- Remove the dust seal

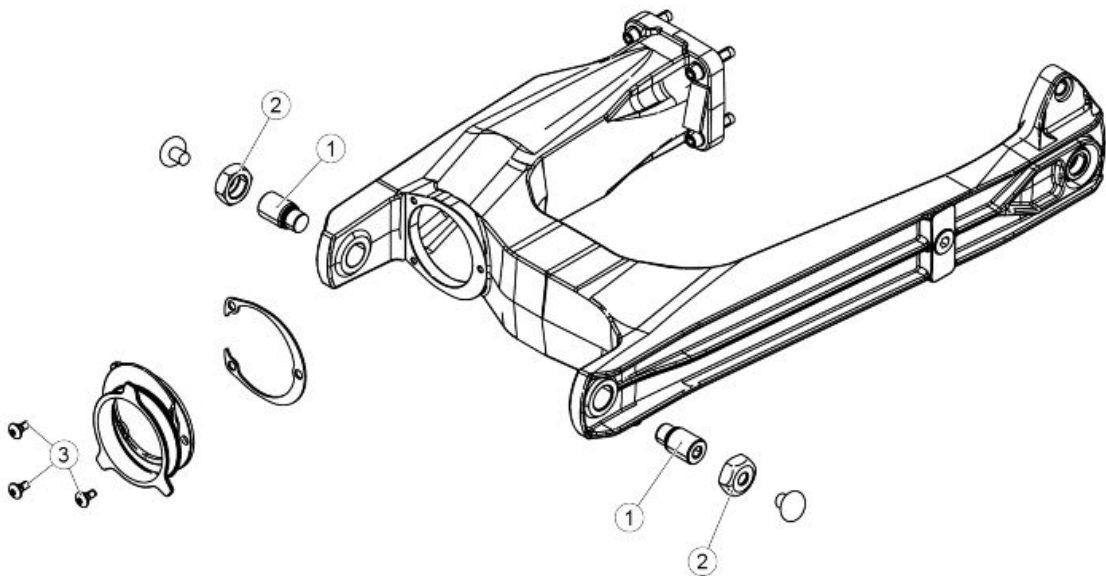


- Remove the locking Seeger ring of the bearing from the side where the encoder/brake disc wheel is present



- Using a generic bearing extractor remove the bearings from both sides

Swinging arm



SWINGARM

pos.	Description	Type	Quantity	Torque	Notes
1	Pins fixing swingarm to gearbox	-	2	-	Manual
2	Locknuts fixing swingarm to gearbox	-	2	50 Nm (36.88 lb ft)	-
3	Torx screws fastening rubber bellows	-	3	6 Nm (4.43 lb ft)	-

Removing

- Remove the mufflers, the rear wheel, and the brake calliper support complete with clamp / ABS sensor, and disconnect the shock absorbers from the support pins.
- Remove the fixing nut of the cable grommet plate and disconnect it from the swingarm



- Cut the sealing clamp and lift the folding

CAUTION

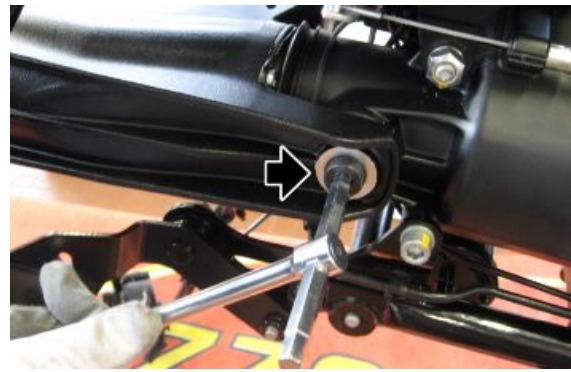
PAY ATTENTION NOT TO CUT AND DAMAGE THE RUBBER FOLDING



- Unscrew the nuts on both sides of the swingarm



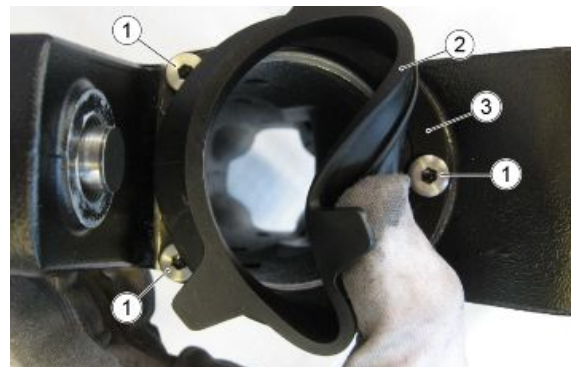
- Loosen the pins so that the oscillating swingarm can be removed from the gearbox.



- Remove the complete swingarm from the gearbox



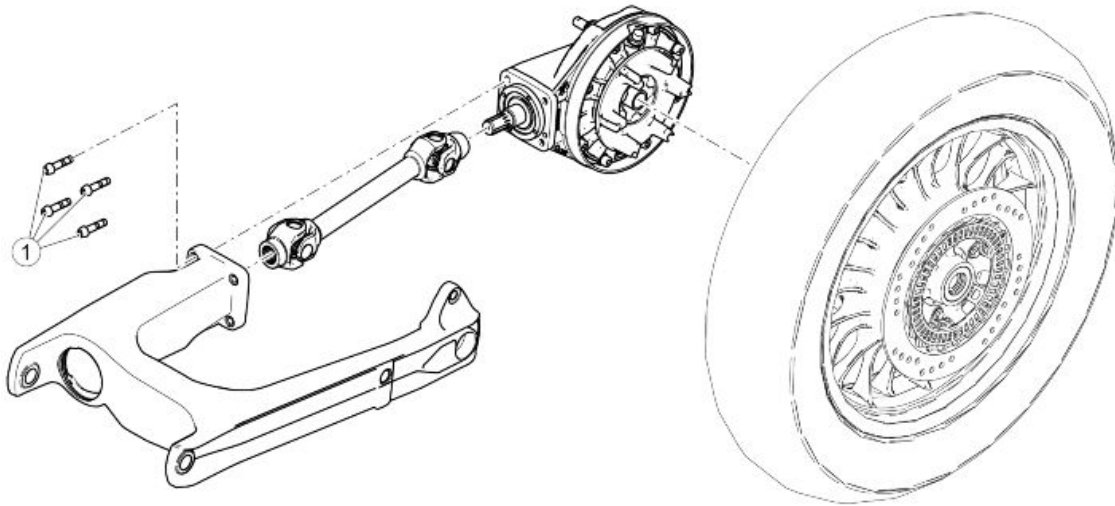
- Remove the three screws (1) to remove the folding (2) complete with retaining ring (3)



Checking

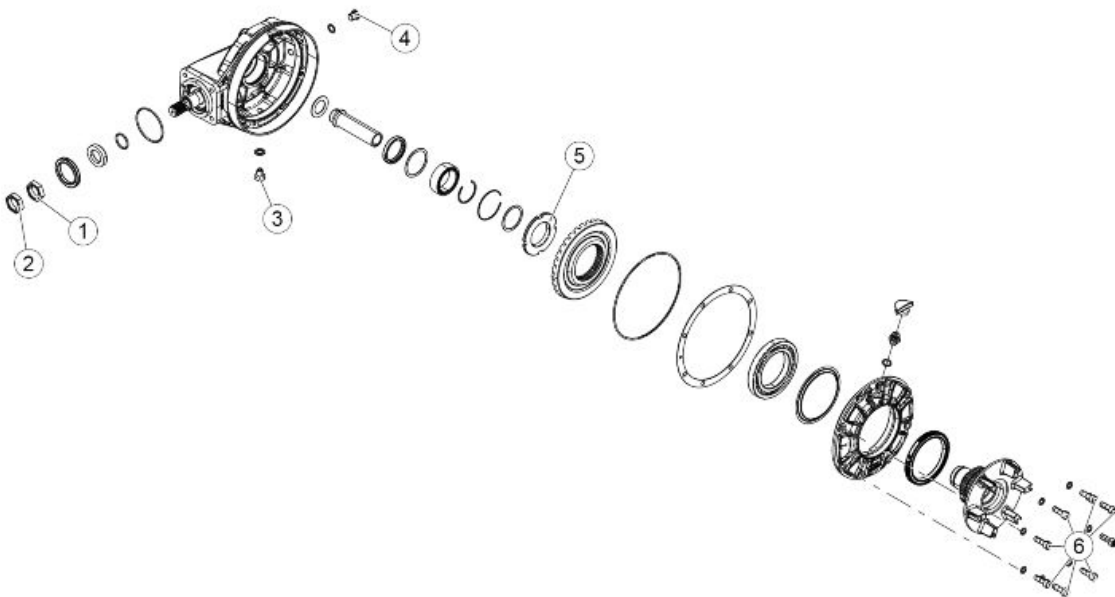
- Check that the universal joint is not damaged, the gear teeth inserting in the sleeve grooves and the grooves on the joint are not deformed or damaged; otherwise, replace the joint.
- Check that the rubber bellows are not cut or pierced; otherwise, replace it.
- Check that the swingarm pin threads and the swingarm fixing nuts are not damaged, deformed or flattened; otherwise, replace them.
- Check that the sleeve grooves are not damaged, deformed or deteriorated; otherwise, replace the sleeve.
- Check that the sleeve outer toothing and internal grooves are not damaged.

Bevel gears



REAR TRANSMISSION

pos.	Description	Type	Quantity	Torque	Notes
1	Swingarm torx SHC fixing screws on the transmission housing	M8x35	4	25 Nm (18.44 lb ft)	-

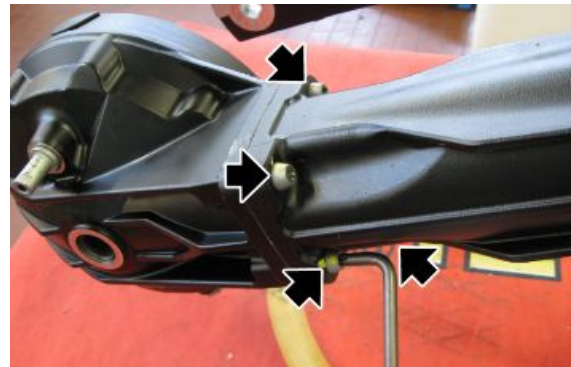


BEVEL GEAR

pos.	Description	Type	Quantity	Torque	Notes
1	Pinion unit retainer nut	M25x1.25	1	100 Nm (73.76 lb ft)	Loct. 243
2	Pinion unit retainer locknut	M25x1.25	1	20 Nm (14.75 lb ft)	Loct. 243
3	Oil drainage plug	M10x1.5	1	30 Nm (22.13 lb ft)	-
4	Oil load cap	M12x1.5	1	25 Nm (18.44 lb ft)	-
5	Crown sprocket fixing ring nut	-	1	100 Nm (73.76 lb ft)	Loct. 243
6	Crown fixing torx screws	M8x25	8	25 Nm (18.44 lb ft)	-

Removing

- Undo and remove the four fixing screws of the bevel gear set



- Pull and remove the bevel gear

**Removal**

- Undo the gearbox cover fixing screws



- Using the suitable special tool, heat the perimeter of the cover



Specific tooling

020151Y Air heater

- If available, use the threaded stud bolts as a guide to remove the cover. Turn the complete box and tapping it on a flat surface, remove the cover.



- Slide off the complete cover from the crown.



- Remove the crown axle thickness.



- Remove the inside spacer.



- Collect the washer.



- Remove the needle bearing.



- Using a suitable tool, disengage the radial snap ring.



- Remove the radial snap ring.



- Using the special tool, heat the seat of the outer track of the needle bearing.

Specific tooling**020151Y Air heater**

- Insert the special tool under the washer and screw the cursor.

Specific tooling**001467Y036 Extract the inner bearing track**

- Insert a suitable bushing on the proper tool and screw the nut while holding the extractor.



- Remove the outer track of the needle bearing.



- Remove the washer.



- Remove the sealing ring. When reassembling use a new ring.



- Using a suitable tool, remove the radial snap ring.



- Using special tool, unscrew the ring nut. At the end of the thread, screw until it stops in such a way as to create the space between the same ring nut and the shoulder washer.

Specific tooling**020999Y Crown ring nut key**

- Insert the special tool under the shoulder washer and screw the cursor.

Specific tooling**19.90.70.00 Extractor for internal ring on drilled bolt**

- Remove the inner track of the needle bearing.



- Remove the shoulder washer.



- Remove the ring nut.



- Remove the crown gear.



- Remove the cover from the gearbox of the splash guard hub.



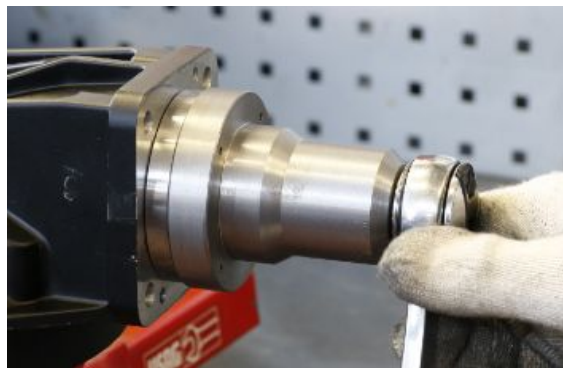
- Remove the O-ring. When reassembling use a new O-ring.



- Rotate the cover and remove the seal ring. When reassembling use a new seal ring.



- Using special tool, unscrew the pinion bearings case.

Specific tooling**020998Y Pinion case key**

- Remove the complete pinion from its seat.



- Using the special tool, lock in the vice, unscrew fastening nut and lock nut of the pinion case bearing.

Specific tooling**021000Y Bevel gear pair support**

- Remove the spacer closing bearings.



- Remove the sealing ring.

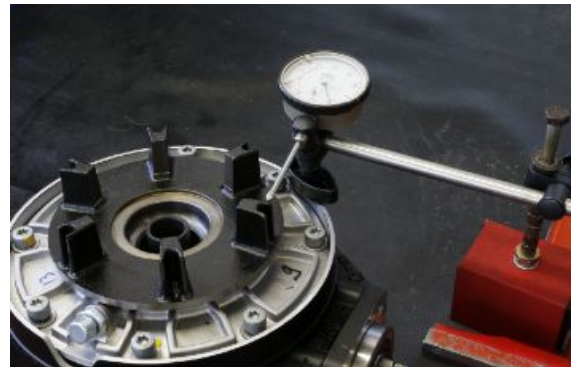


- Remove the O-ring.



Checking

- After assembly of the box, it is necessary to check the play between the pinion and the crown. Clamp in a vice and install a dial gauge by means of a suitable support. The dial gauge tester must be placed the outer end of a tooth positioned at 90°.



Characteristic

Maximum clearance allowed

0.10-0.15 mm (0.004-0.006 in)

Assembling

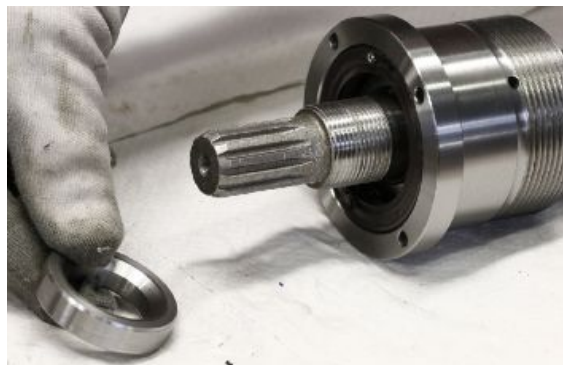
- Insert the new O-ring in the pinion unit, or use the one removed during the dismantling phase if it is intact and undamaged



- Insert the seal ring until it stops



- Insert the spacer closing bearings paying attention that the manufactured part is facing the O-ring so as not to damage it



- Using the special tool, lock in the vice, screw the fastening nut and lock nut of the pinion case bearing to torque.



Specific tooling

021000Y Bevel gear pair support

- Insert the complete pinion in its seat.



- Using special tool, screw the pinion bearings case.

Specific tooling

020998Y Pinion case key



- Using the special tool, insert a new seal ring in the cover.
- On the opposite side of the cover, insert a new O-ring.
- Replace the sprocket hub cover.
- Replace the crown and the fastening ring nut.

Specific tooling

021005Y Punch seals on the bevel gear cover



- Screw the ring nut on the crown to the prescribed torque.



- Insert the shoulder washer. Using the special tool, insert the inner track of the needle bearing. Insert the radial snap ring.

Specific tooling

GU19927900 Punch for pressing bearing inner ring onto drilled pin



- Reposition the crown axle thickness.

NOTE

THE THICKNESS HAS A UNIQUE POSITION IN THE BOX. PAY ATTENTION TO THE CORRECT POSITION BY CHECKING THE CORRESPONDENCE OF THE HOLES WITH THE FASTENING SCREWS.



- Replace the complete cover of the hub in the box.



- Screw to torque the cover fixing screws.

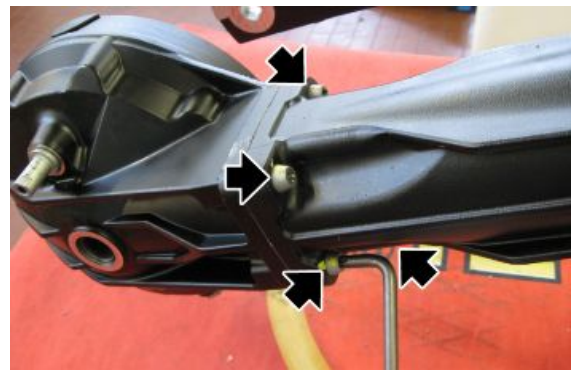


Installing

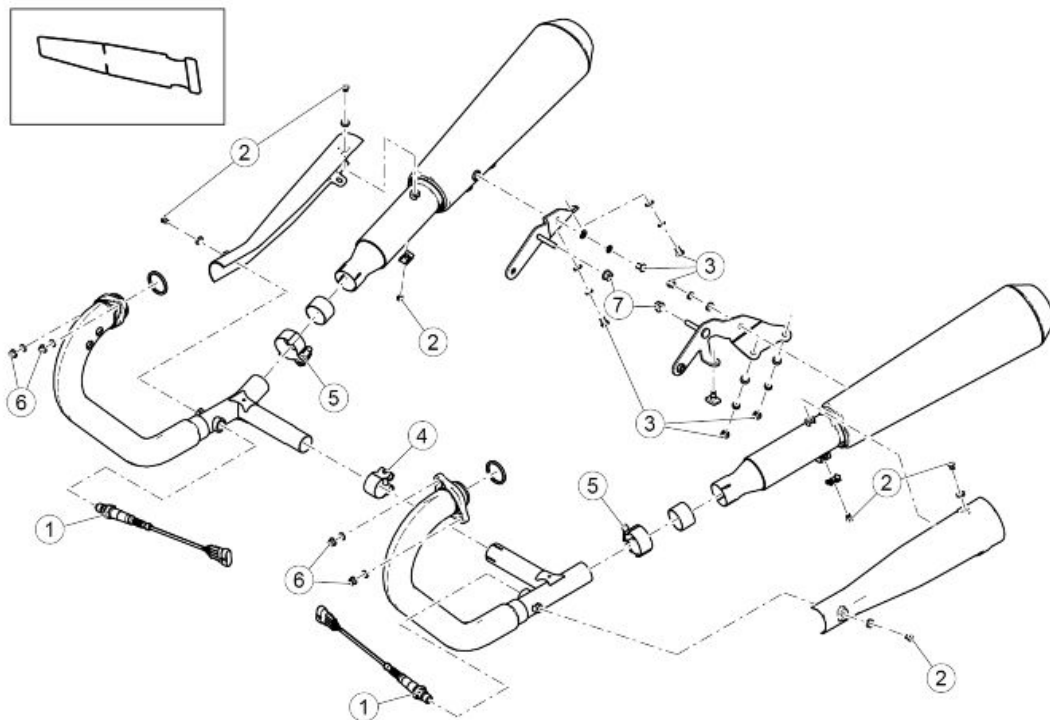
- Insert the bevel gear on the swingarm



- Tighten the four cover fixing screws of the bevel gear to the prescribed torque

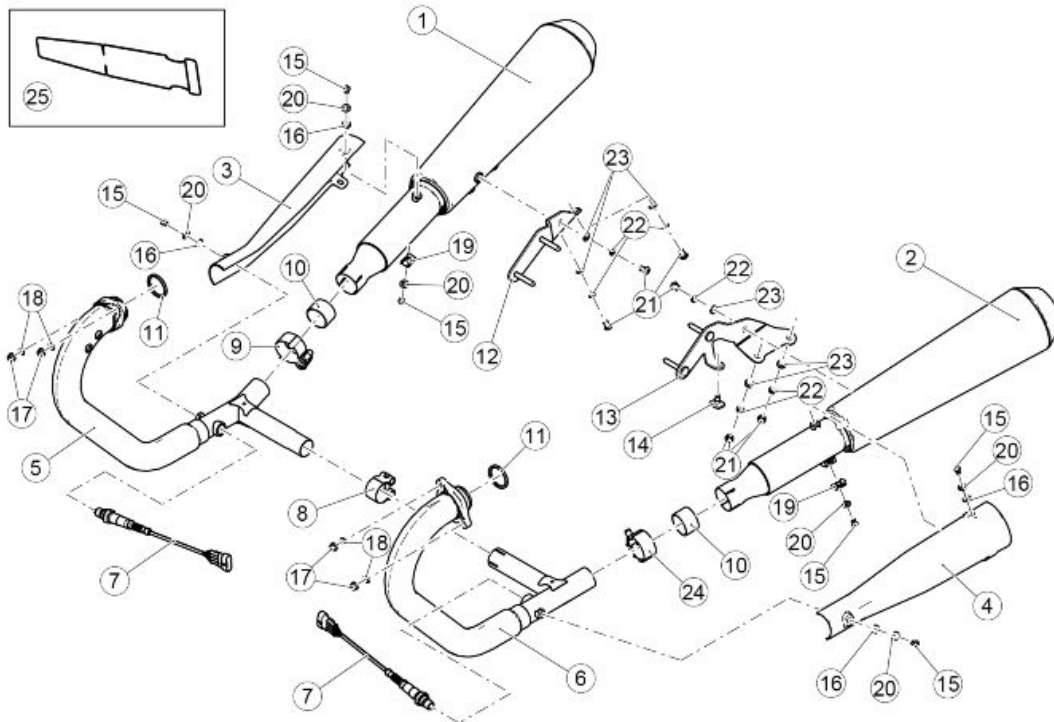


Exhaust



EXHAUST SYSTEM

pos.	Description	Type	Quantity	Torque	Notes
1	Lambda probes fastener	M18x1.5	2	38 Nm (28.03 lb ft)	-
2	Flanged TBEI screws fixing exhausts protections	M6x10	6	8 Nm (5.90 lb ft)	-
3	TBEI screws fixing mufflers to the supports	M8x12	6	25 Nm (18.44 lb ft)	-
4	Fixing exhaust pipes to the compensator	M8	1	25 Nm (18.44 lb ft)	-
5	Fixing exhaust pipes to the mufflers	M10	2	30 Nm (22.13 lb ft)	-
6	Flanged nuts fastening to the engine exhaust pipes	M8	4	25 Nm (18.44 lb ft)	-
7	Nuts fastening mufflers' support to the frame	M8x1.25	4	25 Nm (18.44 lb ft)	-

**key:**

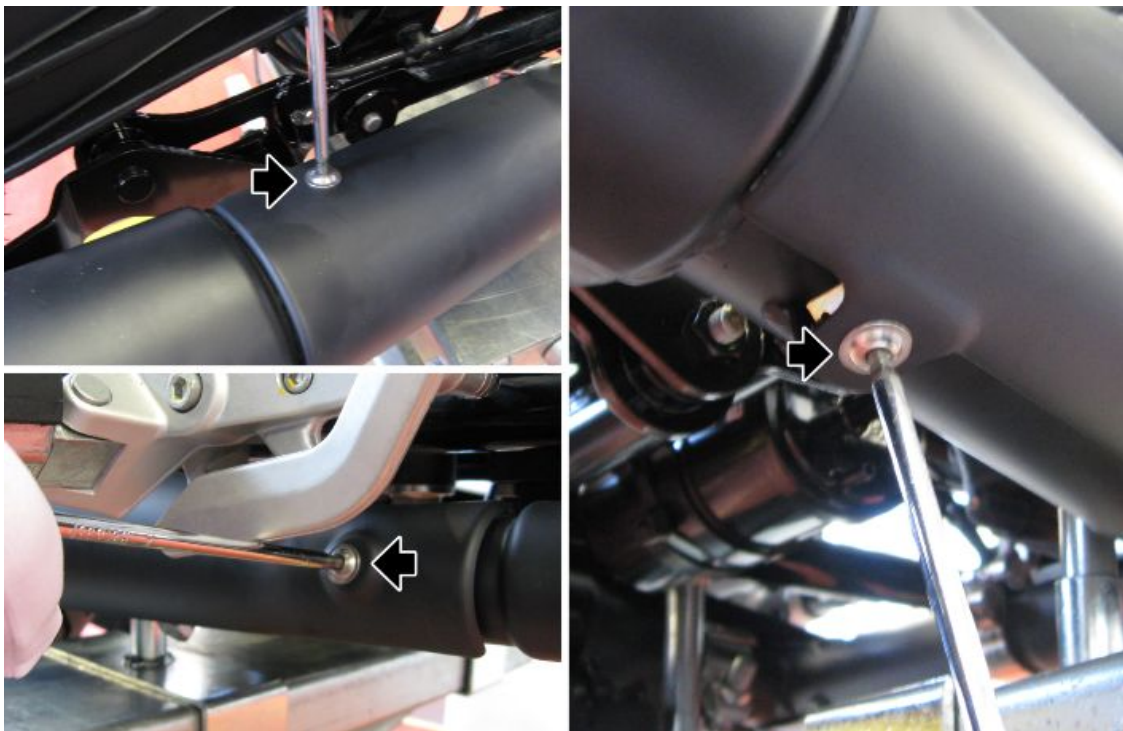
1. Right muffler
2. Left muffler
3. Right converter protections
4. Left converter protections
5. Right exhaust manifold
6. Left exhaust manifold
7. Lambda probe l. 660 mm (25.98 in)
8. Band D. 37 mm (1.46 in)
9. Clamp
10. Bushing
11. Exhaust gasket
12. Right muffler support bracket

13. Left muffler support bracket
14. Rubber ring
15. TBEI flanged screw M6x10
16. Elastic spacer
17. Flanged nut M8
18. Washer 8.4x13x0.8
19. Elastic plate M6
20. Washer
21. TBEI Screws M8x12 conic
22. Washer 8.4x13x0.8
23. Washer 8.4x15x1.5
24. Clamp
25. Heat-protecting cover

Removing the tail pipe

The engine and the exhaust system components get very hot and remain in this condition for a certain time interval after the engine has been switched off. Before handling these components, make sure that you are wearing insulating gloves or wait until the engine and the exhaust system have cooled down.

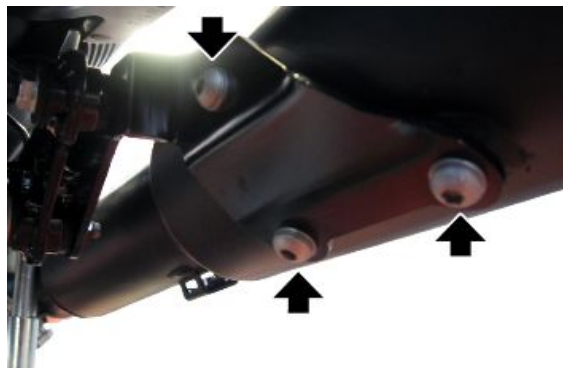
- Remove the three fixing screws of the silencer protection



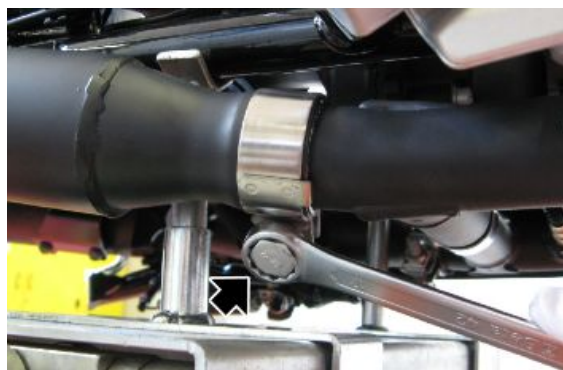
- Remove the silencer protection



- Remove the three fastening screws of the silencer to the support bracket



- Loosen the clamp between the silencer and manifold



- Slide and remove the silencer from the collector

**NOTE**

THE OPERATIONS FOR REMOVING THE EXHAUST TERMINAL, APPLY TO BOTH ENDS

Removing the exhaust manifold

- Remove the fixing nuts (1) of the exhaust manifold paying attention to keep the washers (2)



- Disconnect the connectors of the lambda probes and free the wiring harness of the cable grommet/clamps
- Simultaneously remove both exhaust manifolds



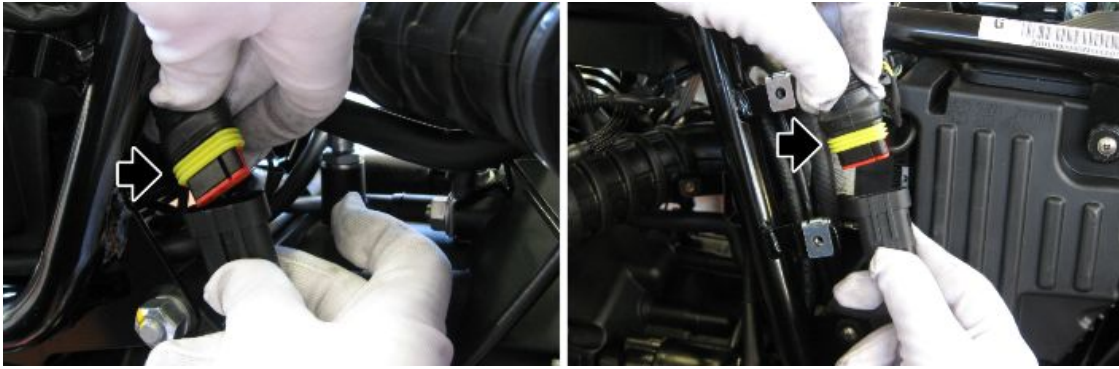
- Unscrew the screw of the central clamp to separate the two manifolds

Removing the lambda sensor

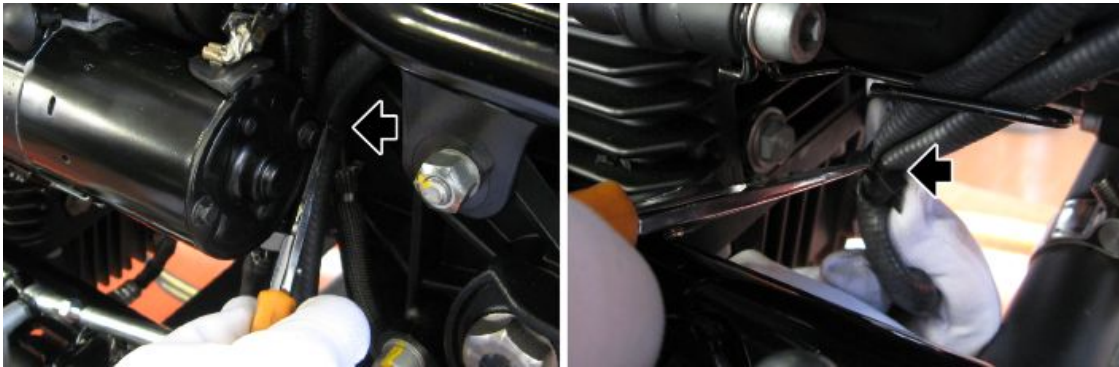
- Remove the side panels to access the connectors of the lambda probes.
- Remove the clamps that secure the connectors to other wiring harnesses



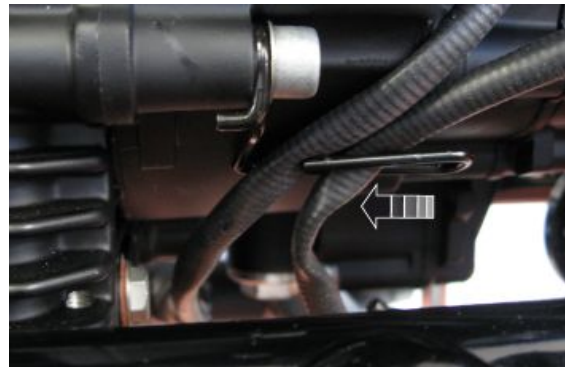
- Disconnect the connectors of the lambda probes



- Remove the clamps that secure the wiring harnesses of the Lambda probes



- Release the wiring harness from the grommet cable

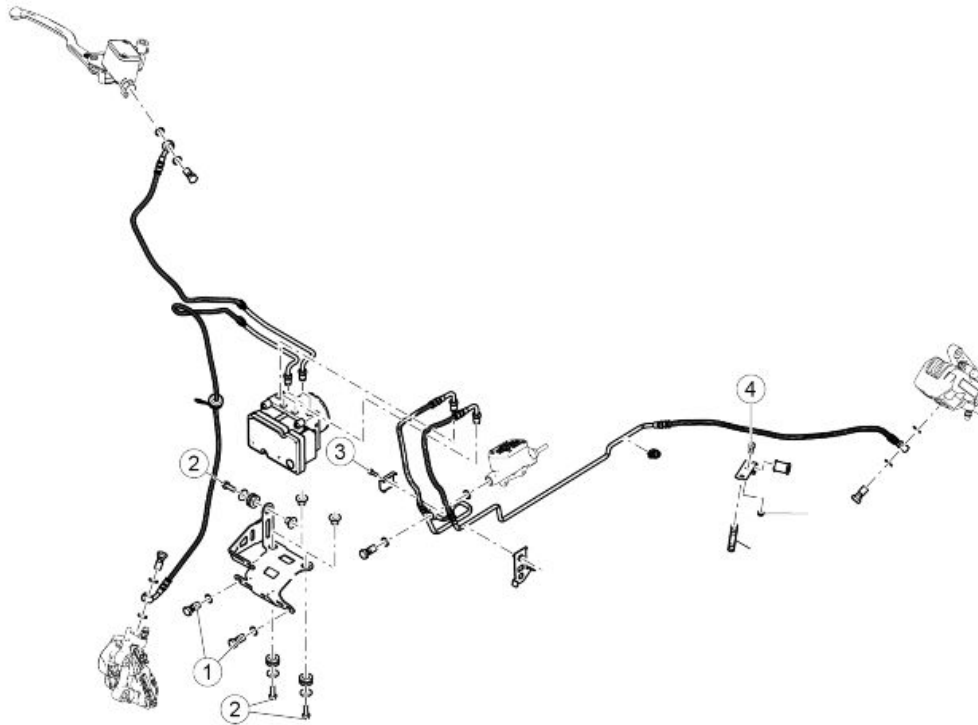


- Unscrew and remove the lambda probes

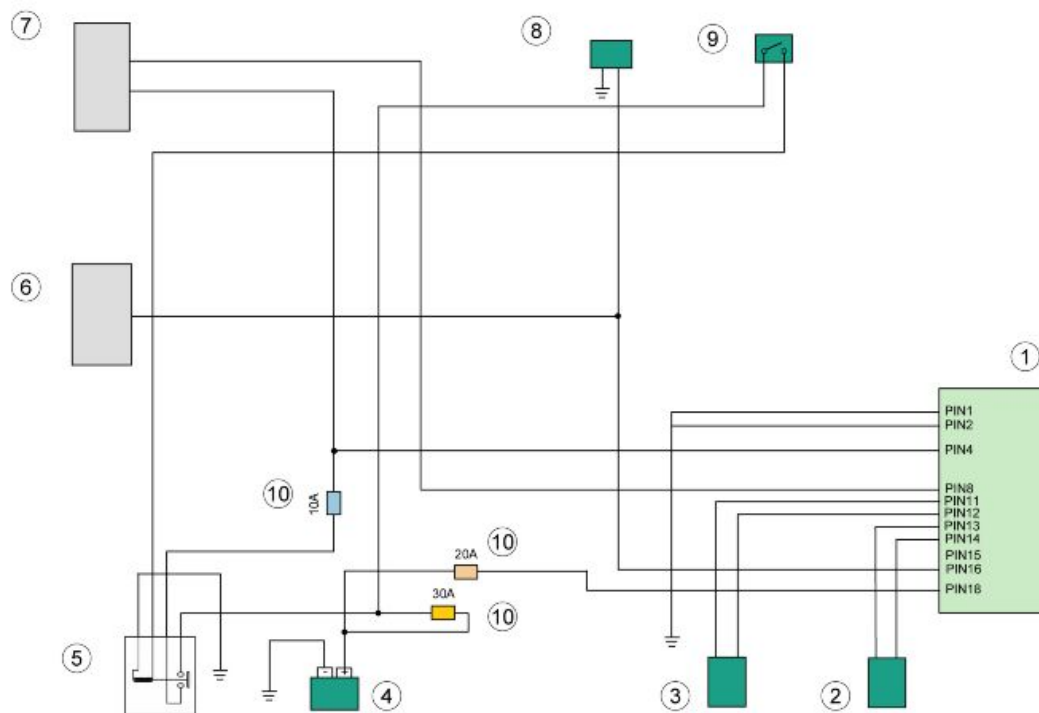
INDEX OF TOPICS

BRAKING SYSTEM

BRAK SYS

ABS**ABS SYSTEM**

pos.	Description	Type	Quantity	Torque	Notes
1	Control unit bracket fastening to the frame	M6x16	2	10 Nm (7.38 lb ft)	-
2	Screws fastening the ABS modulator to the support	M6x20	3	10 Nm (7.38 lb ft)	-
3	SHC screw fastening the brake pipes fixing plate	M4x16	1	3 Nm (2.21 lb ft)	-
4	SHC screw fastening the cable grommet plate	M5x12	1	6 Nm (4.43 lb ft)	-

**key:**

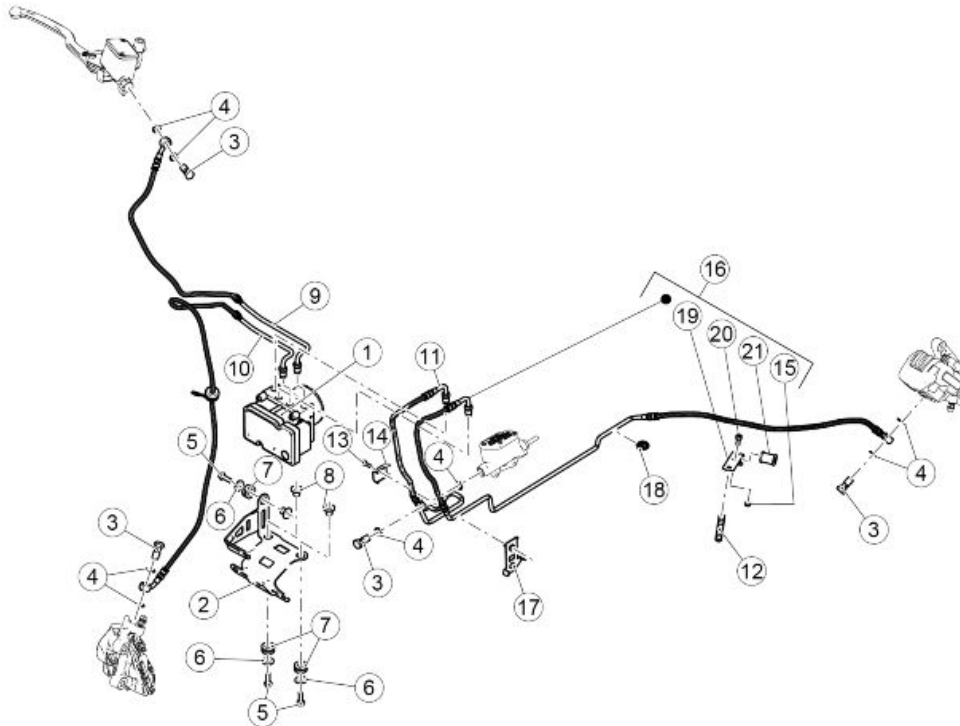
1. ABS ECU control unit
2. Front ABS sensor
3. Rear ABS sensor
4. Battery
5. Main relay
6. ECU
7. Instrument panel
8. K line (diagnosis)
9. Key
10. Fuses

ABS ECU control unit pin configuration

- PIN 1 - GND - Ground
- PIN 2 - PCC1 - Vehicle identification ground connection
- PIN 4 - IGN - Injection
- PIN 8 - WL - Alarm warning light
- PIN 11 - R_SIGN - Rear ABS sensor signal
- PIN 12 - R_GND - Rear ABS sensor ground connection
- PIN 13 - F_GND - Front ABS sensor ground connection
- PIN 14 - F_SIG - Front ABS sensor signal
- PIN 15 - PCC2 - Vehicle identification ground connection

- PIN 16 - ISO_K - K line (diagnosis)
- PIN 18 - KL30 - Power supply

Foreword

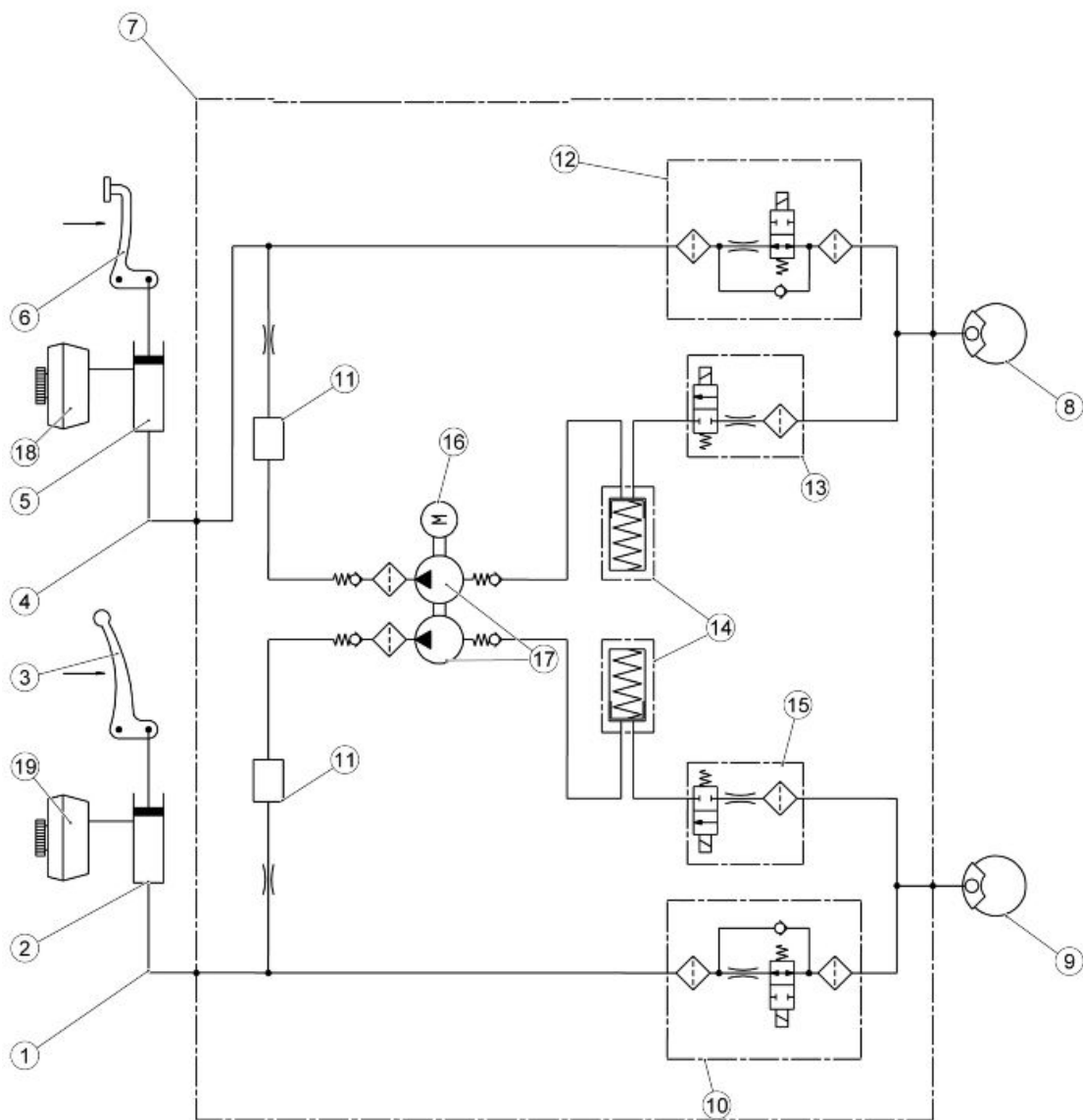


key:

1. ABS control unit
2. ABS control unit support bracket
3. Oil pipe screw
4. Washer 10x14x1.6
5. Screw 6x20
6. Washer 6.6x18x1.6
7. Rubber ring
8. T-shaped bushing
9. ABS HECU pipe - Front pump
10. ABS HECU pipe - Front clamp
11. ABS HECU pipe - Rear pump
12. Stud bolt
13. SHC screw M4x16
14. Pipe fixing plate
15. Low self-locking nut
16. Nut

- 17.Brake pipe mounting plate
- 18.Cable guide
- 19.Clamp
- 20.M5x12 SHC screw
- 21.Ring

Operating diagram



ABS functional diagram key

1. Front system circuit
2. Front brake pump
3. Front brake lever
4. Rear system circuit
5. Rear brake pump
6. Rear brake pedal control
7. ABS control unit
8. Rear brake calliper
9. Front Calliper
10. Front brake circuit intake solenoid valve (normally open)
11. Humidifier
12. Rear brake circuit intake solenoid valve (normally open)
13. Rear brake exhaust circuit solenoid valve (normally closed)
14. Rear/front brake circuit low pressure accumulator
15. Front brake exhaust circuit solenoid valve (normally closed)
16. DC electric motor
17. Double circuit hydraulic pump (ABS)
18. Rear brake reservoir
19. Front brake reservoir

ABS OPERATION**General specifications:**

The front circuit is similar to the rear circuit.

- The ABS inlet valve (10 - 12) is normally open and it is closed only when the system intervenes to avoid wheel locking.
- The exhaust valve (13 - 15) is normally closed and it is opened only when the system intervenes to avoid wheel locking.
- When the system is in standby, the ABS processor never stops monitoring the speed of the wheels in order to assess potential wheel slippage.
- When in standby, the system does not intervene at all when the rider brakes; the braking system is the same as the one without ABS.

Stages in ABS cycle (the following operations refer to the front circuit but are also applicable to the rear one):

A - Brake activation: the rider starts braking as he would usually do.

B - Pressure reduction: it coincides with danger recognition (wheel slippage above threshold): the system closes the inlet valve (10-12) and opens the exhaust valve (13-15) temporarily.

At this stage the rider cannot increase the pressure on the callipers (8-9) and the system reduces the pressure on the callipers partially. The excess fluid temporarily fills the front reservoir (18-19) until the ABS pump (17) self-activates and delivers the fluid back to the brake pump (2-5).

C - Pressure maintained: the pressure in the callipers (8-9) remains low until total recovery of speed / wheel grip.

The system restores the fluid taken from the calliper (8-9) in the section of the system between the brake pump (2-5) and the ABS inlet valve (10-12).

D - Pressure restored: by opening the inlet valve (10-12) momentarily, the pressure of the callipers (8-9) is increased until maximum deceleration is reached. Then, the system gives the control over the braking back to the rider.

E - If the wheel does not reach complete grip, the system continues operating as before until complete grip is obtained or until the vehicle stops. An error can be detected if the duration of the pressure reduction phase exceeds the pre-set time limit.

ABS SYSTEM DESCRIPTION

The ABS system is a device to avoid wheels locking in case of emergency braking, increasing vehicle braking stability when compared to a traditional braking system.

Sometimes when the brake is operated, the tyre locks with a consequent loss of grip, which makes it difficult to control the vehicle. A position sensor (3) on the tone wheel (2), forming an integral unit with the vehicle wheel, "reads" the status of the vehicle wheel spotting any possible lock.

A control unit (1) signals this out and adjusts the pressure in the braking circuit accordingly.

NOTE

WHEN THE ABS SYSTEM STARTS WORKING, A VIBRATION IS FELT ON THE BRAKE LEVER.



THE WHEEL ANTILOCK BRAKING SYSTEM DOES NOT PREVENT FALLS WHILE ON A BEND. AN EMERGENCY BRAKING WITH THE VEHICLE INCLINED, HANDLE BAR TURNED, ON UNEVEN OR SLIPPERY ROADS, OR WITH POOR GRIP CREATES LACK OF STABILITY DIFFICULT TO HANDLE. THEREFORE, RIDE CAREFULLY AND SENSIBLY AND ALWAYS BRAKE GRADUALLY. BRAKING WHILE TURNING A CORNER IS SUBJECT TO LAWS OF PHYSICS WHICH NOT EVEN ABS CAN ELIMINATE.



When the sensors (3) detect a significant speed difference between the rear and the front wheels (for example, when rearing up on the back wheel), the ABS system could take this as a dangerous situation.

In this case, two things may occur:

- The ABS system intervenes by releasing pressure from the calliper until the wheel turns again at the same speed of the other wheel. It is not possible to brake for an instant.
- if the speed difference lasts long, the system may detect an error and deactivate the ABS system. As a consequence, the system works like any regular braking system.

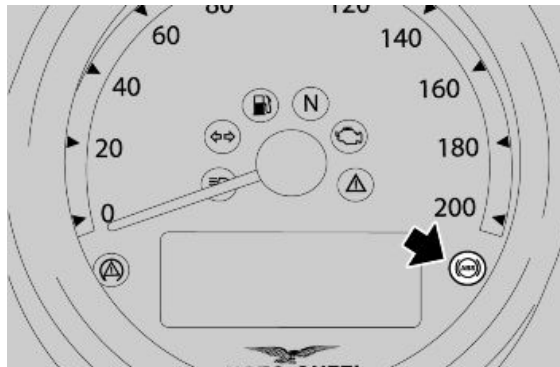
Riding with an active ABS system

- When turning the key on, the ABS warning light turns on and flashes until reaching 5 km/h (3.11 mph); at this point it turns off.

CAUTION

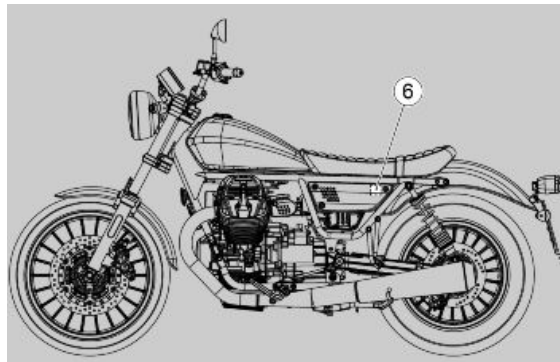


THE STEADY LIGHTING OR THE CONTINUOUS FLASHING OF THE ABS WARNING LIGHT INDICATES THE PRESENCE OF AN ANOMALY AND THE DEACTIVATION OF THE ABS FUNCTIONALITY.



20 A fuse (ABS Main fuse) (6)

Protects: ABS Control unit.



Guide to diagnosis

PREMISE

Each time the key is ON, at least one current or stored* error of the ABS system is often detected:

- the ABS warning light turns on permanently

The ABS system is deactivated!

The system operates perfectly just as any other braking system without ABS

* The diagnosis requires exceeding the 5 km/h.

Each time the key is ON, if at least one current or stored* error of the ABS system is not detected:

- the ABS warning light flashes

When the 5 km/h (3.11 mph) are exceeded:

- if errors are not detected

- the ABS warning light turns off
- if at least one malfunction is detected
- the ABS warning light turns on permanently

The ABS system is deactivated!

The system operates perfectly just as any other braking system without ABS.

The detection of malfunctions may require more or less time according to the type of failure.

Error detection logic foresees that for the errors to be diagnosed one or more conditions must persist within a given time.

If during this given time one of the conditions is missing but then it comes back, the timer is reset and the system is no longer able to diagnose the error.

The ABS system is still inactive.

Example:

- error code 5D93 requires some minutes before it is diagnosed during the given time:
- the ABS warning light ABS keeps flashing

GUIDE TO ABS FAULT DIAGNOSIS

1. ABS LAMP ON

2. CONNECT PADS

PADS COMMUNICATE? (NO, go to 3; YES, go to 4)

3. PERFORM THESE CHECKS:

- A. PIN 1 Ground connection
- B. +12V at PIN 18
- C. +12V at PIN 4 with key ON

4. ARE THERE ANY ERRORS? YES, go to point 5; NO, go to 6)

5. CHECK THE ERRORS TABLE

6. ABS WARNING LIGHT ACTIVATION

IS IT ACTIVATED?(YES, go to point 7; NO, go to point 8)

7. CONTACT TECHNICAL SERVICE

8. PERFORM THESE CHECKS:

- A. Cable continuity between PIN8 of the ABS control unit connector and the instrument panel warning light.
- B. Check connectors - refer to the operations described in the chapter

If the above checks are OK, the causes can be:

- C. ABS Control unit malfunction
- D. Instrument panel malfunction

NOTE: to carry out a check using the diagnostic tool on the wheel speed sensor, refer to the operations described in chapter "ELECTRICAL SYSTEM/CHECKS AND CONTROLS/SPEED SENSOR" chapter.

Use of diagnostics instrument for ABS system

Abs screen pages

ECU INFO screen page

This screen page shows general data regarding the control unit, for example software type, mapping, control unit programming date



PARAMETERS screen page

This screen page shows the parameters measured by the several sensors (engine revs, engine temperature, etc.) or values set by the control unit (injection time, ignition advance, etc.)



PARAMETERS

P.A.D.S. characteristic	Value/example	Unit of measurement	Notes
Front wheel speed	-	km/h	-
Rear wheel speed	-	km/h	-
Battery voltage	-	V	-
Front brake circuit pressure	-	bar	-

Quality test of the sensors

When turning the wheel or acting on the brake, a variation of parameters must be detected.

ACTIVATION screen page

This screen page is used to delete errors in the control unit memory and to activate some systems controlled by the control unit.



ACTIVATION

P.A.D.S. characteristic	Value/example	Unit of measurement	Notes
ABS warning light			
Error clearing			
Freezes and saves the parameter and states values			

ERRORS screen page

This screen page displays any errors detected in the vehicle (ATT) or stored in the control unit (MEM) and you can check that the cancellation of error (STO) has taken place.



ERRORS

P.A.D.S. characteristic.	Value/example	Units of measurement	Notes
Comparison of front and rear wheel	C1024		Excessive difference
Rear wheel speed sensor electrical diagnosis	C1031		Short circuit or open circuit to negative or short circuit to positive
Rear wheel speed sensor functional diagnosis	C1032		Signal not valid
Front wheel speed sensor electrical diagnosis	C1033		Short circuit or open circuit to negative or short circuit to positive
Front wheel speed sensor functional diagnosis	C1034		Signal not valid
Inside error	C1014		Solenoid valve relay failure
Inside error	C1015		Recirculation pump failure
Inside error	C1021		Control unit failure
Inside error	C1048		Rear circuit output solenoid valve failure
Inside error	C1049		Rear circuit output solenoid valve failure
Inside error	C1052		Rear circuit input solenoid valve failure
Inside error	C1054		Front circuit inlet solenoid valve failure

P.A.D.S. characteristic.	Value/example	Units of measurement	Notes
Low power supply voltage	C1058		
High power supply voltage	C1059		
Configuration error	C1089		
CAN error	U2921		Controller error
CAN error	U2922		Line failure (busoff)
CAN error	U2924		Failed reception from instrument panel
CAN error	U2925		Failed reception from injection ECU
+ button	U2926		Connect to the injection control unit diagnostics
- button	U2927		Connect to the injection control unit diagnostics
Inside error	C1331		Pressure sensor failure
Inside error	C1332		Pressure sensor failure (Offset)
Inside error	C1333		Pressure sensor failure (Power supply)

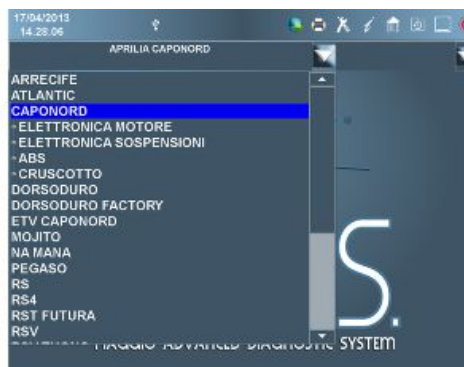
PADS report mode

In the following are described the procedure to be performed through the diagnostic tool in order to generate an errors report:

- When started the program, select the brand.



- Select the vehicle and the component.

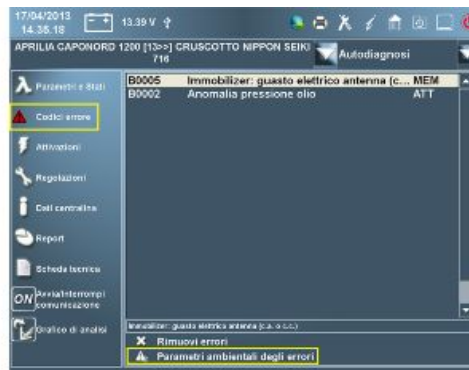


- Select Self-diagnosis.

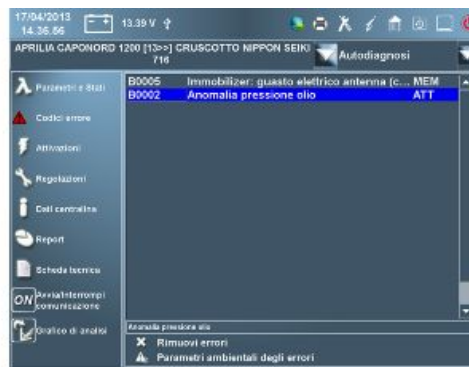


- Go to the page Error codes.

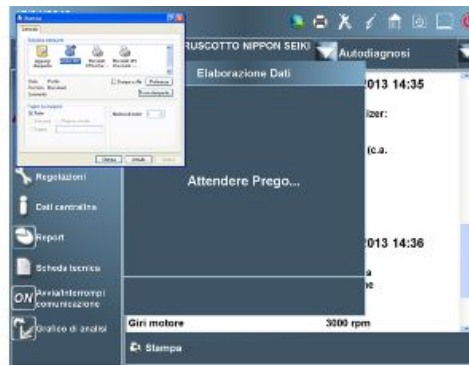
- Select an error and show the Ambient parameter error(when provided).



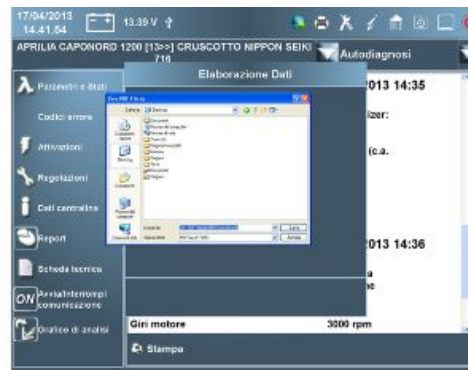
- Repeat the operation by selecting each error and showing the corresponding Ambient parameter error (when provided).



- Go to the page Report and then on Print and select the virtual PDF printer.



- If there is no PDF printer, there are several free programs, ask the information systems to install it.
- Name the file with a name that contains the main information of the vehicle and the analysed component e.g. CN1200-Chassis0465-Instrument panel.

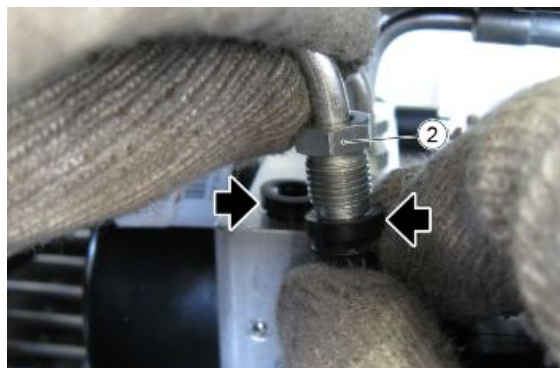
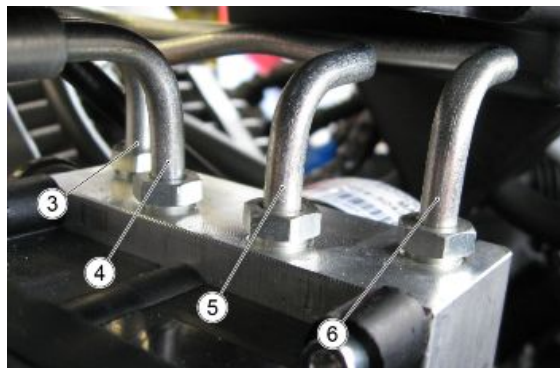


Modulator

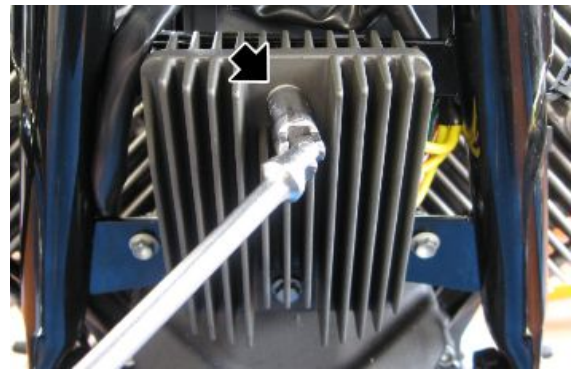
Before removing the modulator, it is necessary to completely purge the braking system.

MODULATOR REMOVAL

- Remove the horn.
 - Disconnect the connector (1).
-
- With a felt-tip pen, mark a reference on the pipes and on the ABS control unit to avoid inverting them when refitting
 - Remove the oil pipes in the order (3) - (4) - (6) - (5)
-
- Unscrew the nut of the oil pipe (3) and cover both the pipe and the hole on the modulator.



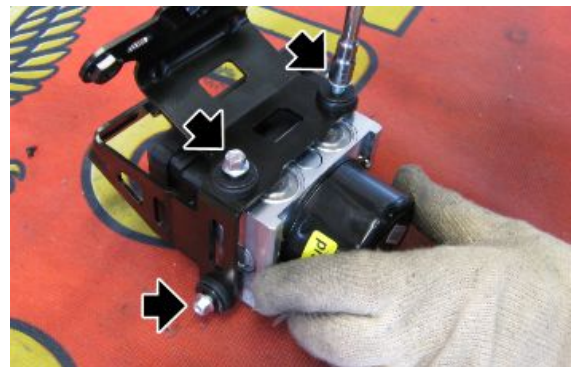
- Remove the fixing screw from the voltage regulator that holds the support bracket of the ABS control unit.



- Operating from the left side of the motorcycle, remove the ABS modulator

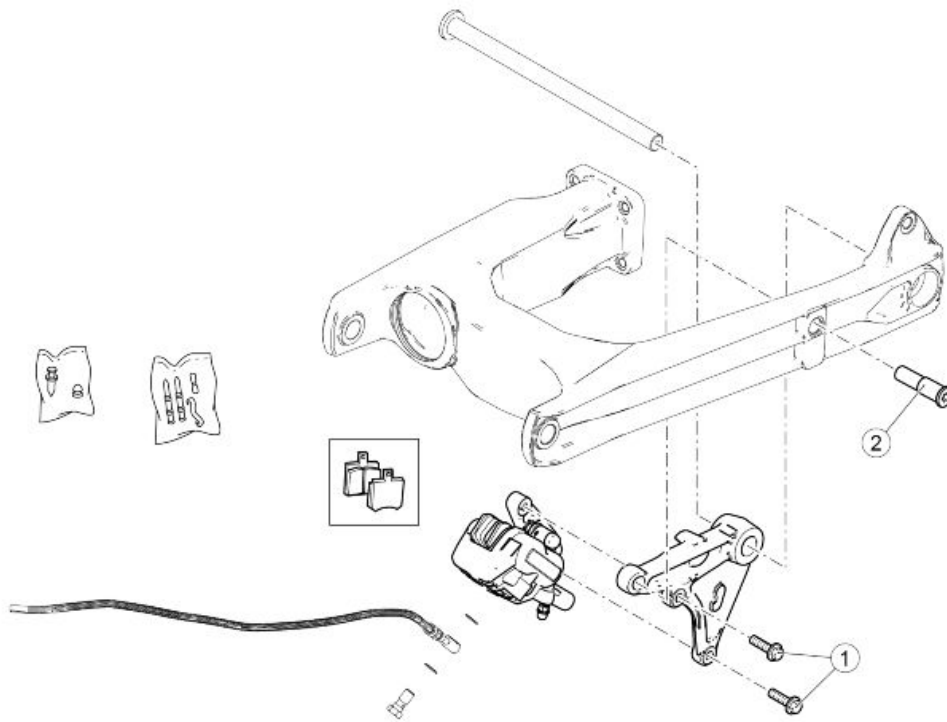


- To remove the ABS modulator from the support, remove the three fixing screws



Rear brake calliper

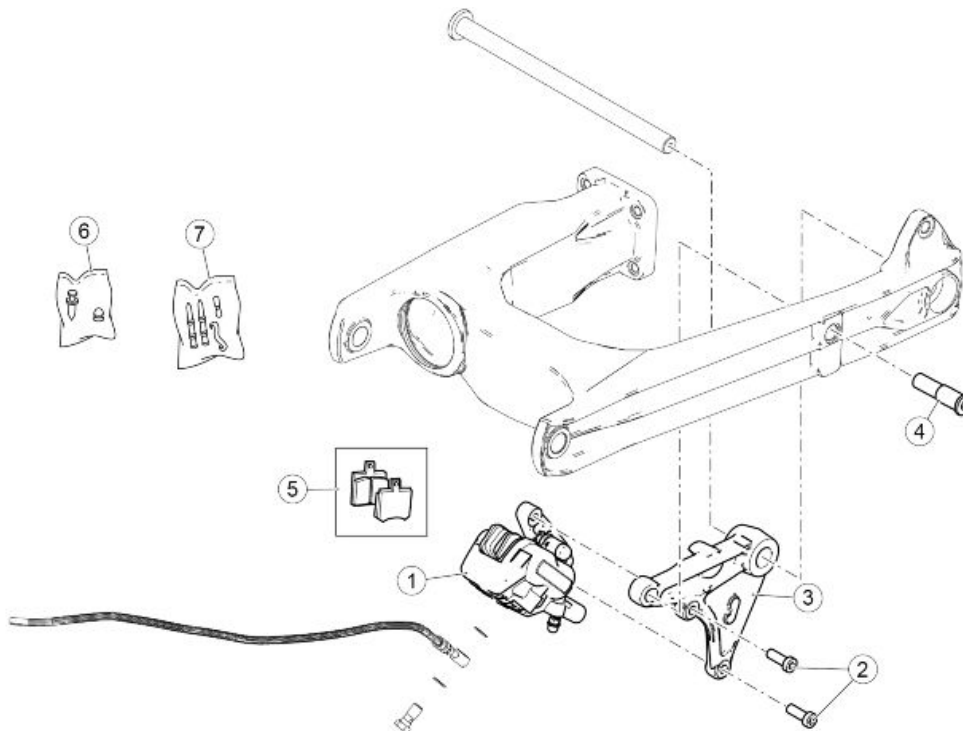
Tightening torque



REAR BRAKE CALLIPER

pos.	Description	Type	Quantity	Torque	Notes
1	Flanged TE screws fixing rear brake calliper	M8x30	2	25 Nm (18.44 lb ft)	-
2	Rear brake calliper support pin	M16	1	35 Nm (25.81 lb ft)	-

Rear brake calliper components



key:

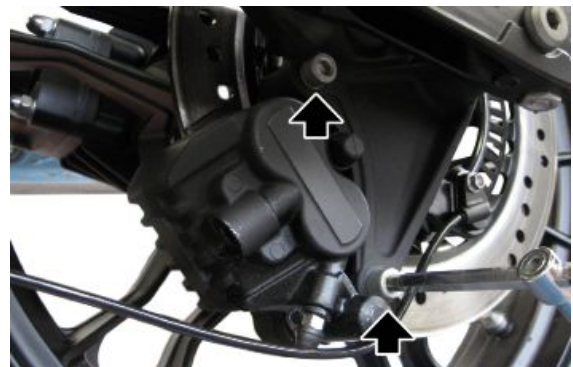
1. Rear brake calliper
2. TE Flanged screw
3. Rear brake calliper support
4. Pin
5. Brake pads copy
6. Bleed with hood
7. Pins and springs kit

Removal

- Obtain a special container and empty the system
- Remove the screw fixing the brake pipe to the clamp



- Remove the two calliper fixing screws

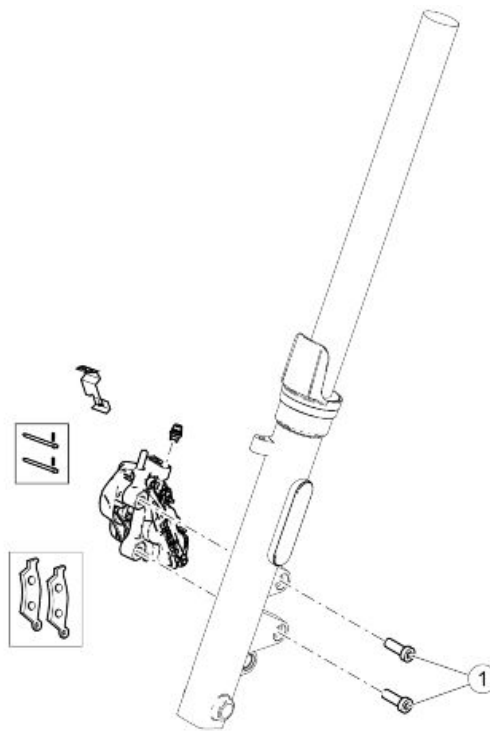


- Remove the calliper



Front brake calliper

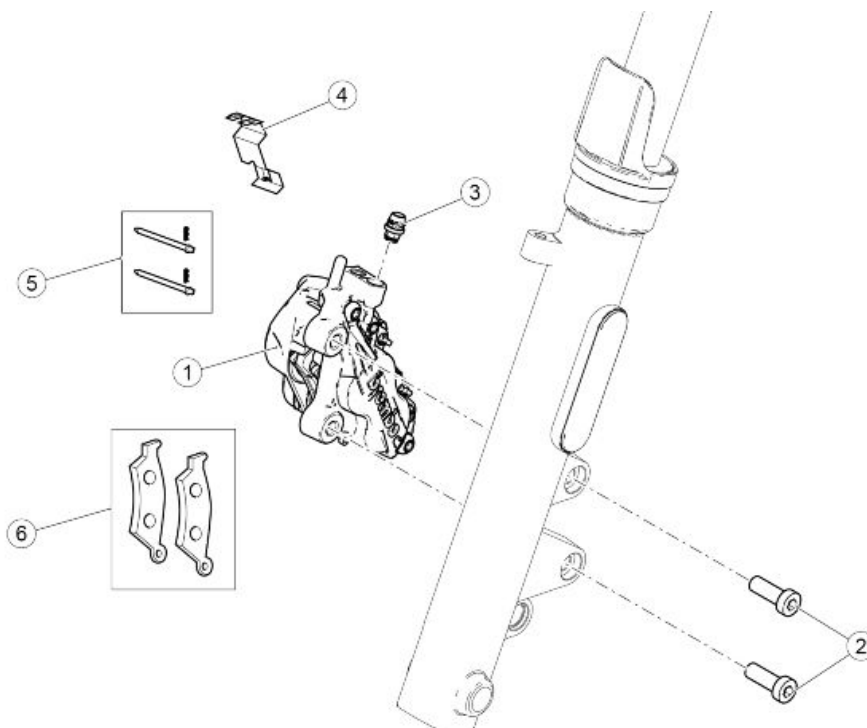
Tightening torque



FRONT BRAKE CALLIPER

pos.	Description	Type	Quantity	Torque	Notes
1	Brake calliper fixing screws	M10x30	2	50 Nm (36.88 lb ft)	-

Front brake calliper components



key:

- 1. Front brake calliper

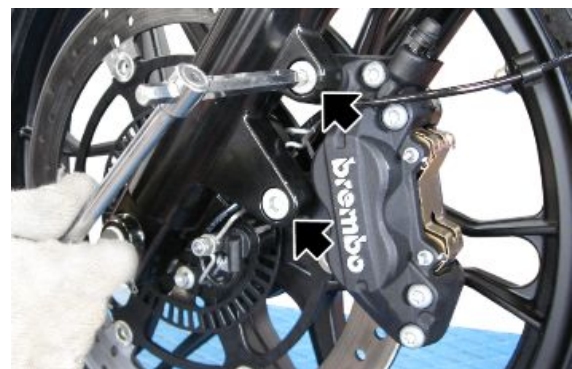
2. SHC screws M10x1.25
3. Bleed with hood
4. Spring
5. Pins and spring clamp
6. Brake pads

Removal

- Obtain a special container and empty the system
- Remove the screw fixing the brake pipe to the clamp



- Remove the two calliper fixing screws

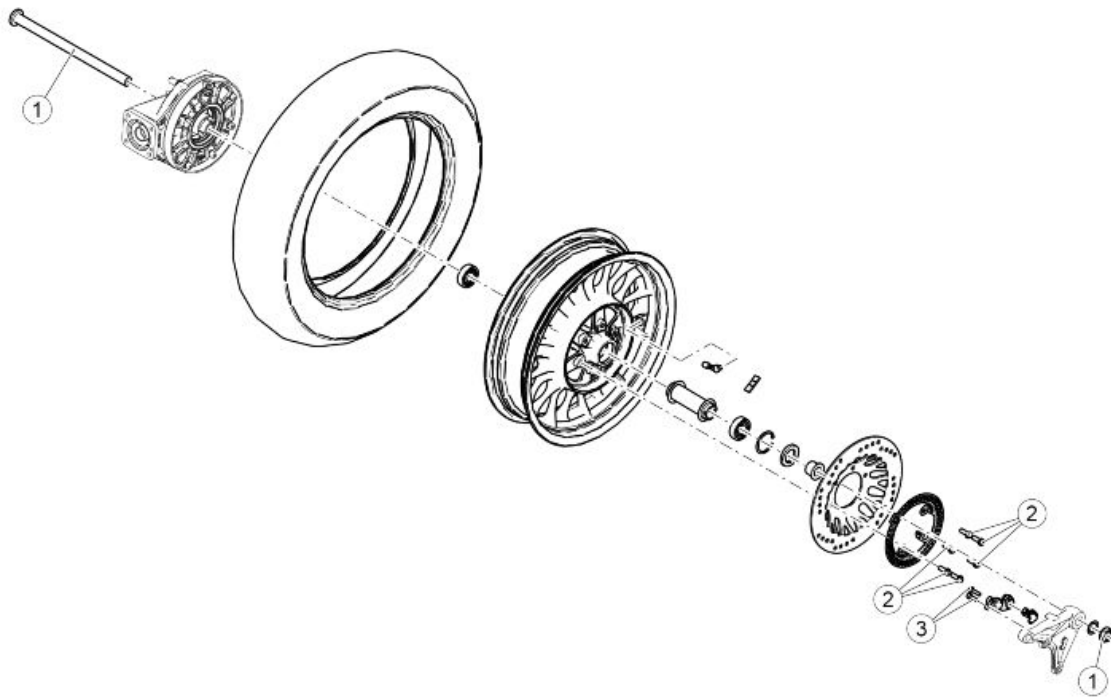


- Remove the calliper



Rear brake disc

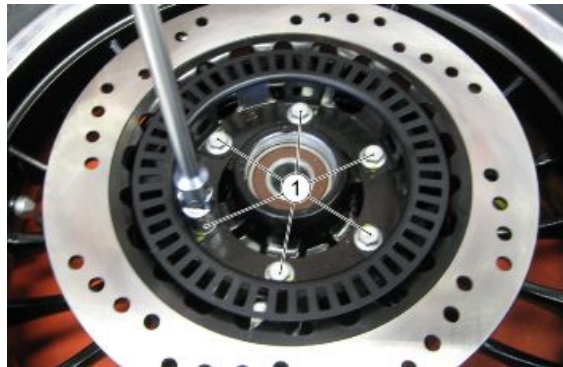
Tightening torque

**REAR WHEEL**

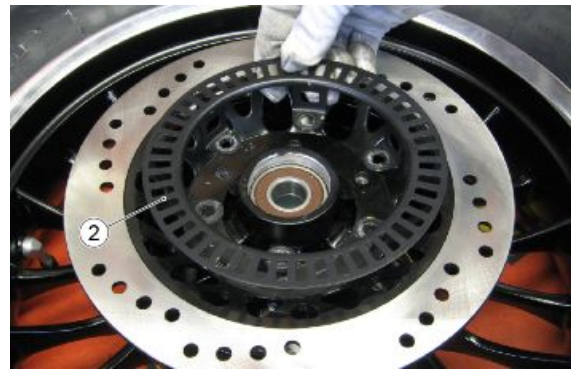
pos.	Description	Type	Quantity	Torque	Notes
1	Rear wheel axle fixing nut	M20	1	120 Nm (88.51 lb ft)	-
2	Flanges TE screws fastening phonic wheel and brake disc	M8x22	6	25 Nm (18.44 lb ft)	Loct. 243
3	SHC screws fastening ABS sensor support	M6x12	2	10 Nm (7.38 lb ft)	-

Removal

- Remove the rear wheel
- Remove the six fixing screws (1) of the tone wheel and the front disc



- Remove the tone wheel (2)



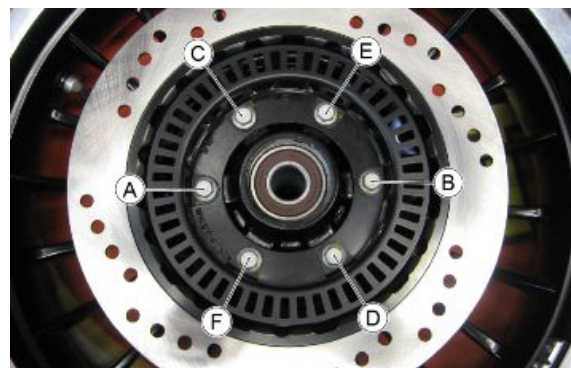
- Remove the brake disc (3)



DURING REFITTING, APPLY LOCTITE 243 ON THE THREAD OF THE BRAKE DISC SCREWS (1).

CAUTION

DURING REFITTING, SCREW ALL THE SCREWS (1) MANUALLY AND TIGHTEN THEM OPERATING DIAGONALLY FOLLOWING THIS SEQUENCE: A-B-C-D-E-F.

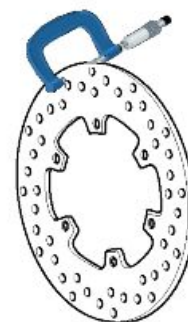


Disc Inspection

CAUTION

THE BRAKE DISC SHAPE DOES NOT CHANGE THE OPERATING AND MAINTENANCE SPECIFICATIONS OF THE SYSTEM.

- The following operations are to be carried out with brake disc fitted on the wheel.
- Check the disc for wear by measuring the minimum thickness with a micrometer in different points. If the minimum thickness, even in a single point

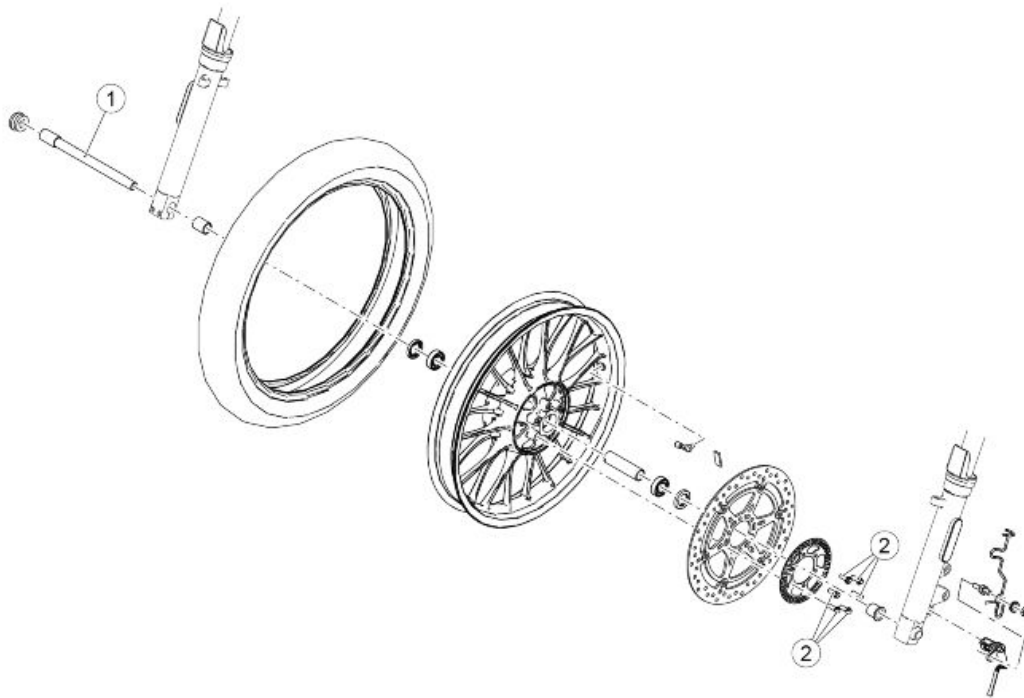


of the disc, is less than the minimum value, replace the disc.

Disc thickness minimum value: 4.5 mm (0.18 in)

Front brake disc

Tightening torque



FRONT WHEEL

pos.	Description	Type	Quantity	Torque	Notes
1	Front wheel axle	M18	1	80 Nm (59.00 lb ft)	-
2	Phonic wheel/brake disc fastening screws	M8x18	6	25 Nm (18.44 lb ft)	Loct. 243

Removal

- Remove the rear wheel
- Remove the six fixing screws (1) of the tone wheel and the front disc



- Remove the tone wheel (2)



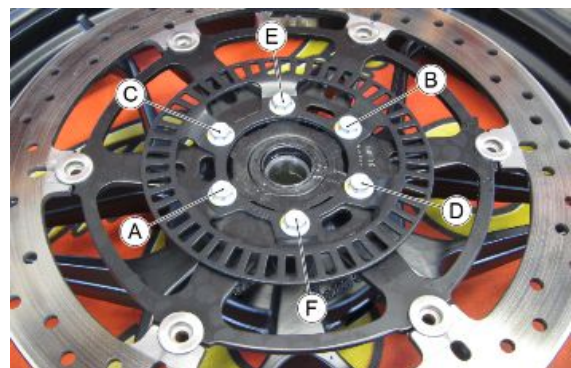
- Remove the brake disc (3)



DURING REFITTING, APPLY LOCTITE 243 ON THE THREAD OF THE BRAKE DISC SCREWS (1).

CAUTION

DURING REFITTING, SCREW ALL THE SCREWS (1) MANUALLY AND TIGHTEN THEM OPERATING DIAGONALLY FOLLOWING THIS SEQUENCE: A-B-C-D-E-F.

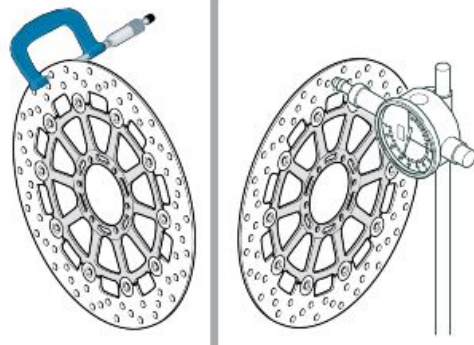


Disc Inspection

CAUTION

THE FRONT BRAKE DISC SHAPE DOES NOT CHANGE THE OPERATING AND MAINTENANCE SPECIFICATIONS OF THE SYSTEM.

- The following operations must be carried out with the brake discs fitted on the wheel; they refer to a single disc, but are valid for both.
- Check the disc for wear by measuring the minimum thickness with a micrometer in different points. If the minimum thickness, even in a single point



of the disc, is less than the minimum value, replace the disc.

Disc thickness minimum value: 4 mm (0.16 in)

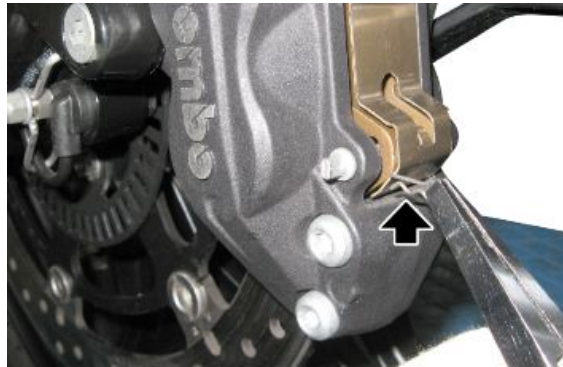
- Using a dial gauge, check that the maximum oscillation of the disc does not exceed the tolerance; otherwise, replace it.

Disc oscillation tolerance: 0.15 mm (0.0059 in)

Front brake pads

Removal

- Remove the Seeger locking the retaining pins of the brake pads



- Remove the brake pad retaining pins



- Collect the protection plate.



- Remove the brake pads



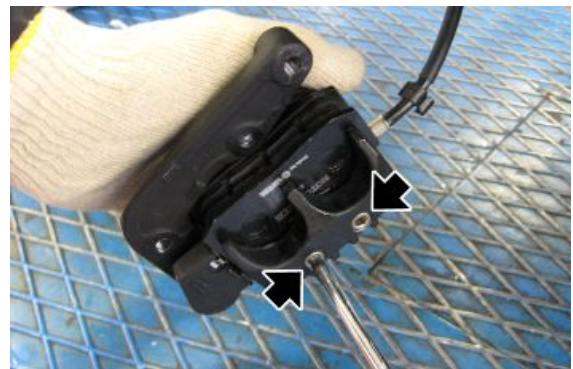
Rear brake pads

Removal

- Remove the rear brake calliper



- Remove the screws locking the brake pads



- Remove the brake pads



Bleeding the braking system

Front

Any air trapped in the hydraulic circuit acts as a cushion, absorbing much of the pressure applied by the brake pump and minimising the braking power of the calliper.

The presence of air is signalled by the "sponginess" of the brake control and by poor braking efficiency.

CAUTION

CONSIDERING THE DANGER FOR VEHICLE AND RIDER, IT IS STRICTLY NECESSARY, AFTER REFITTING BRAKES AND RESTORING THE BRAKING SYSTEM TO THE REGULAR USE CONDITIONS, THAT THE HYDRAULIC CIRCUIT BE AIR PURGED.

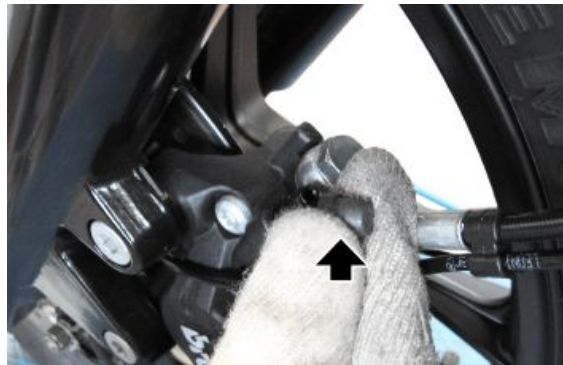
NOTE

THE VEHICLE MUST BE ON LEVEL GROUND TO BE PURGED. WHILE PURGING THE HYDRAULIC SYSTEM, FILL THE RESERVOIR WITH THE NECESSARY QUANTITY OF BRAKE FLUID. CHECK THAT, DURING THE OPERATION, THERE IS ALWAYS BRAKE FLUID IN THE RESERVOIR.

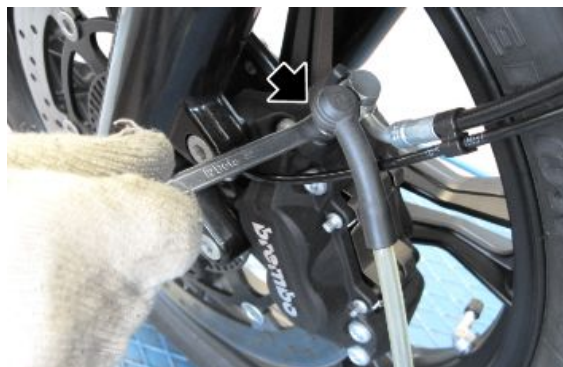
The bleeding procedure can be performed in a traditional way or using specific tools such as vacuum pumps or similar.

In the following is shown the "traditional" bleeding procedure.

- Remove the rubber protection cover from the bleed valve.



- Insert the transparent plastic pipe in the front brake calliper bleed valve and slide the other end of this pipe in a container to collect the fluid.
- Remove the front brake fluid reservoir cap.
- Operate the brake lever and then open the bleed valve on the calliper 1/4 of a turn to let the air out.
- Close the bleed again before reaching the lever end of the stroke and repeat the operation until there is no air.



- Repeat the procedure for both callipers.
- Screw the bleeding valve and remove the pipe.
- Top-up the reservoir until the correct brake fluid level is obtained.
- Refit and block the front brake oil reservoir cap.
- Refit the rubber protection cover.

Rear

Any air trapped in the hydraulic circuit acts as a cushion, absorbing much of the pressure applied by the brake pump and minimising the braking power of the calliper.

The presence of air is signalled by the "sponginess" of the brake control and by poor braking efficiency.

CAUTION

CONSIDERING THE DANGER FOR VEHICLE AND RIDER, IT IS STRICTLY NECESSARY, AFTER REFITTING BRAKES AND RESTORING THE BRAKING SYSTEM TO THE REGULAR USE CONDITIONS, THAT THE HYDRAULIC CIRCUIT BE AIR PURGED.

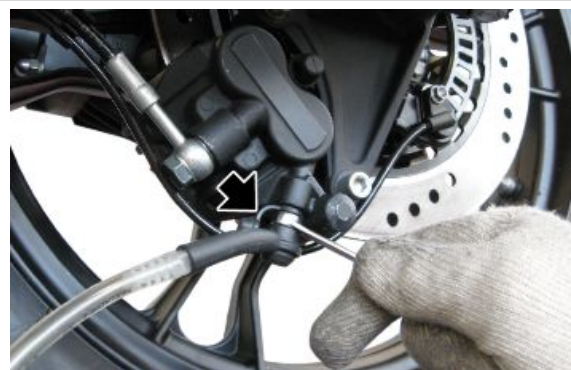
NOTE

THE VEHICLE MUST BE ON LEVEL GROUND TO BE PURGED. WHILE PURGING THE HYDRAULIC SYSTEM, FILL THE RESERVOIR WITH THE NECESSARY QUANTITY OF BRAKE FLUID. CHECK THAT, DURING THE OPERATION, THERE IS ALWAYS BRAKE FLUID IN THE RESERVOIR.

- Remove the rubber protection cover from the bleed valve.



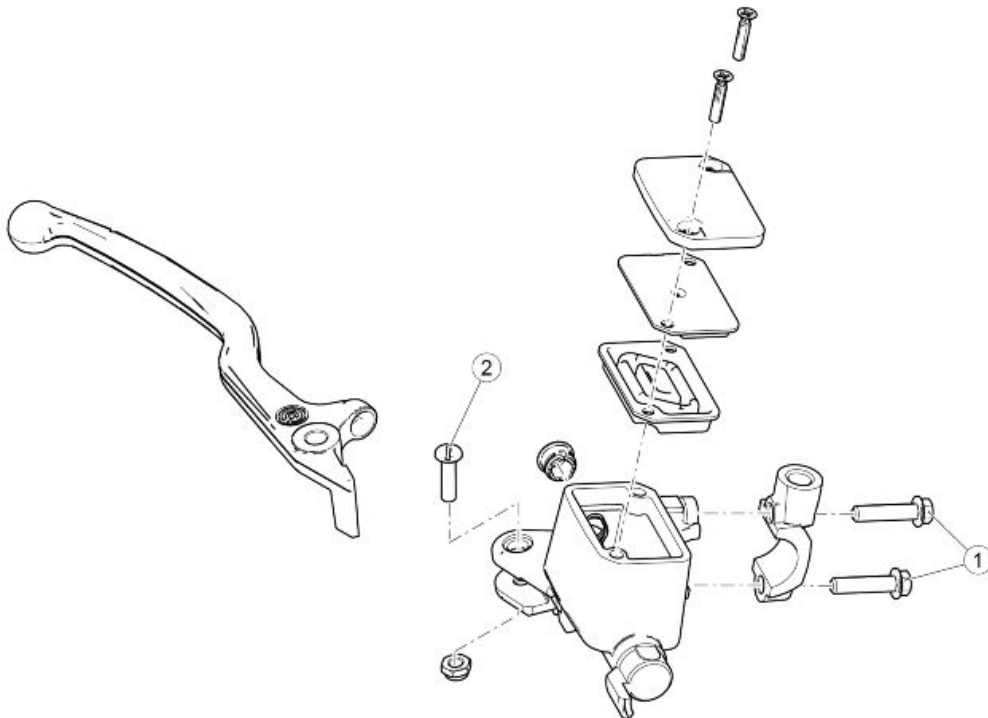
- Insert the transparent plastic pipe in the rear brake calliper bleed valve and insert the other end of this pipe into a container to collect the fluid.
- Remove the rear brake fluid reservoir cap.
- Operate the brake lever and then open the bleed valve on the calliper 1/4 of a turn to let the air out.



- Close the bleed again before reaching the lever end of the stroke and repeat the operation until there is no air.
- Screw the bleeding valve and remove the pipe.
- Top-up the reservoir until the correct brake fluid level is obtained.
- Refit and lock the rear brake oil reservoir cap.
- Refit the rubber protection cover.

Front brake pump

Tightening torque



FRONT BRAKE PUMP

pos.	Description	Type	Quantity	Torque	Notes
1	Brake pump U-bolt fixing screws	M6x25	2	10 Nm (7.38 lb ft)	-
2	Brake pump control pin	M6	1	10 Nm (7.38 lb ft)	-

Removal

- Remove the rear-view mirror
- Drain off the front brake system
- Disconnect the brake switch connectors



- Remove the two brake pump fixing screws



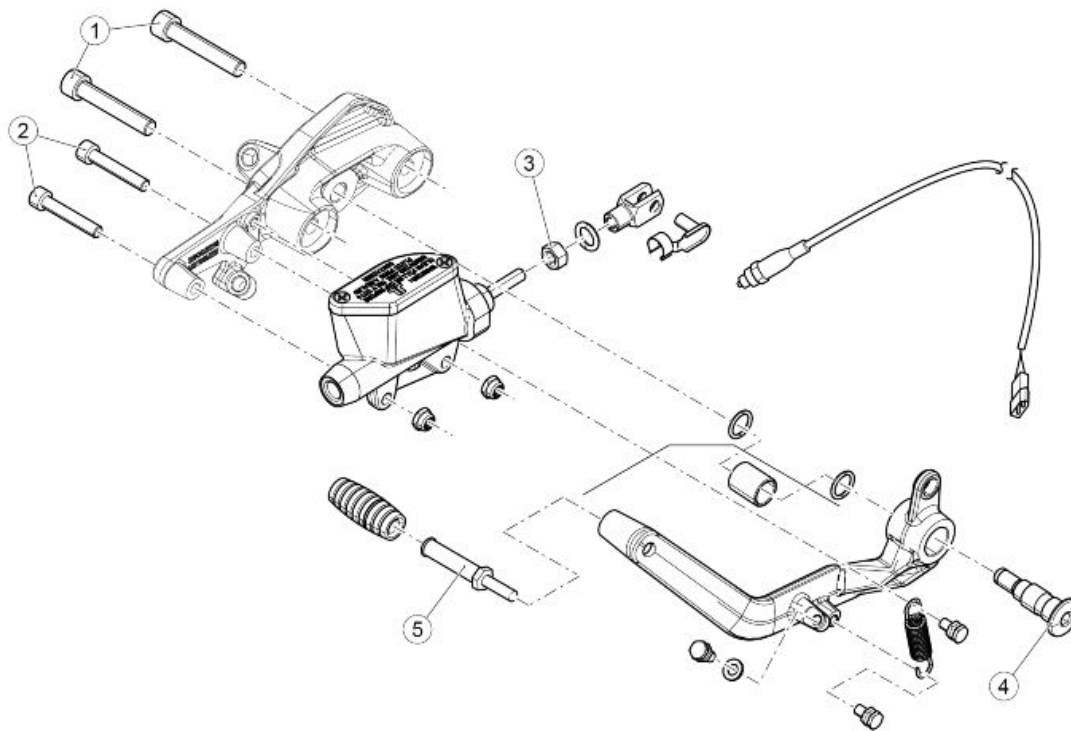
- Remove the brake pump

CAUTION

DURING REFITTING FILL UP THE BRAKE SYSTEM WITH THE RELATIVE BLEEDING PROCEDURE TO AVOID AIR BUBBLES IN THE SYSTEM

Rear brake pump

Tightening torque

**REAR BRAKE PUMP**

pos.	Description	Type	Quantity	Torque	Notes
1	SHC screws fastening the gearbox support plate to the chassis	M10x55	2	55 Nm (40.57 lb ft)	-
2	SHC screws fastening the brake pump to the gearbox support plate	M6x25	2	10 Nm (7.38 lb ft)	-
3	Rear brake rod lock nut	M6	1	10 Nm (7.38 lb ft)	-
4	Brake lever pin	M8	1	20 Nm (14.75 lb ft)	-
5	Rear brake pedal	M8	1	25 Nm (18.44 lb ft)	-

INDEX OF TOPICS

BODYWORK

BODYW

Disassembling the lock

- Remove the left side fairing
- Remove the fork spring



- Remove the cable support plate



- Extract the ignition switch assembly externally



Taillight assy.

- Remove the license plate cover
- Remove the locking clamp of the tail-light wiring harness / arrows and disconnect the connector



- Remove the three fastening screws of the headlight to the support bracket



- Remove the taillight together with the wiring harness

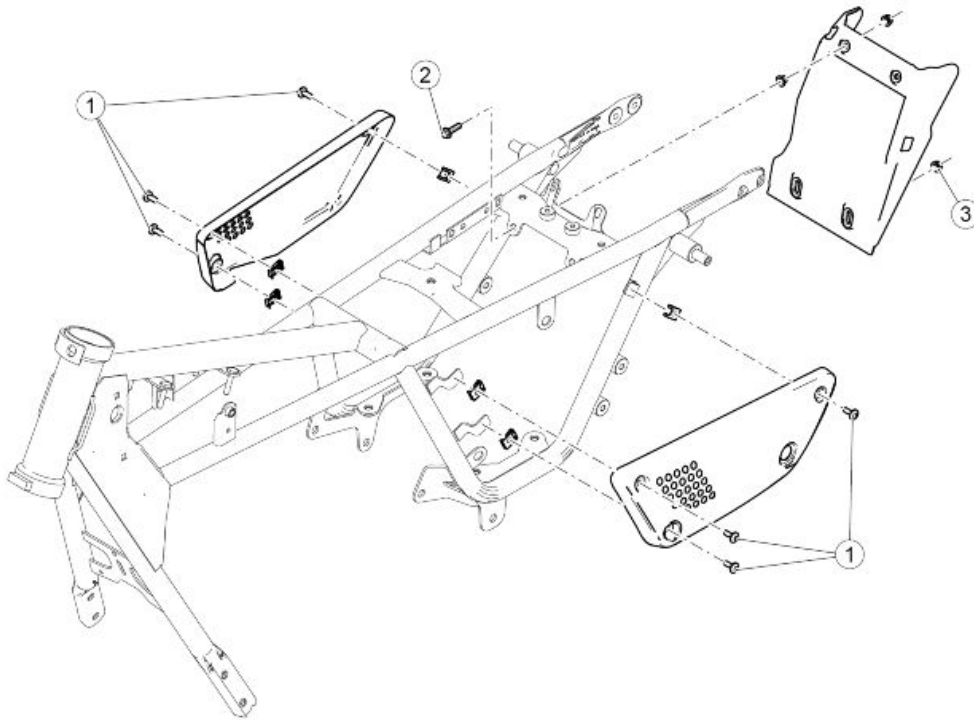


- During reassembly, pay attention to correctly position the present grommet on the taillight wiring harness, the groove of the license plate holder



Side body panels

Tightening torque

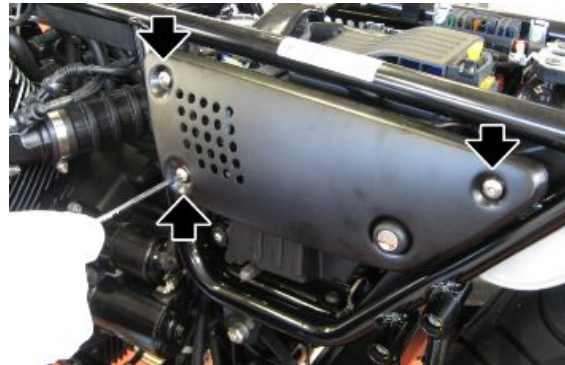


CENTRAL BODYWORK

Pos.	Description	Type	Quantity	Torque	Notes
1	TBEI screws fastening fearing	M5x15	6	4 Nm (2.95 lb ft)	-
2	TE flanged screws fastening top splash guard	M6	2	10 Nm (7.38 lb ft)	-
3	Flanged nuts fastening bottom splash guard	M6	2	10 Nm (7.38 lb ft)	-

THE OPERATIONS BELOW ARE VALID FOR REMOVAL OF BOTH SIDE PANELS

- Remove the three side fairing fixing screws



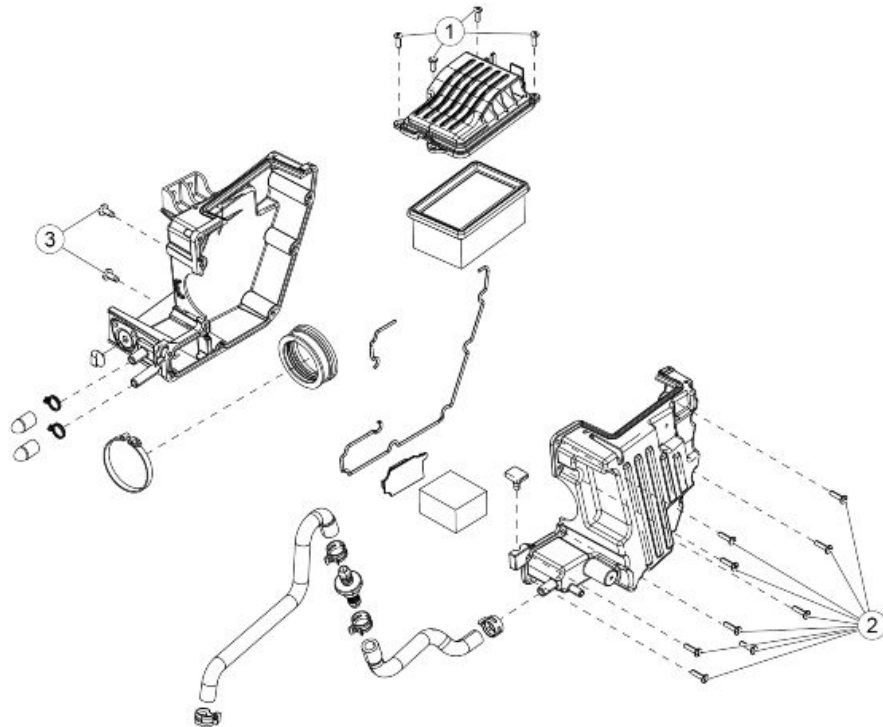
- To remove the left side fairing the saddle opening cable must be unhooked from the ignition switch assembly



License plate holder

Air box

Tightening torque



FILTER BOX

pos.	Description	Type	Quantity	Torque	Notes
1	Air filter box cover fastening self-threading screw	M5x14	4	3 Nm (2.21 lb ft)	-
2	SWP screws fixing filter box to chassis	M5x20	2	3 Nm (2.21 lb ft)	-
3	SWP filter box locking screws	M5x20	9	3 Nm (2.21 lb ft)	-

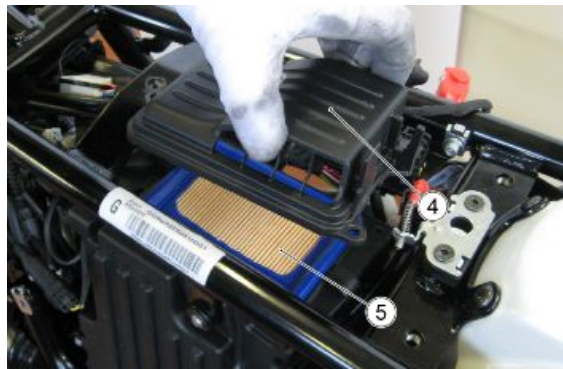
- Remove the saddle, the side panels and the battery complete with the rubber support
- Slide from the support present in the filter casing connector (1) and the ABS fuses (2)



- Remove the four fastening screws (3) of the air filter cover



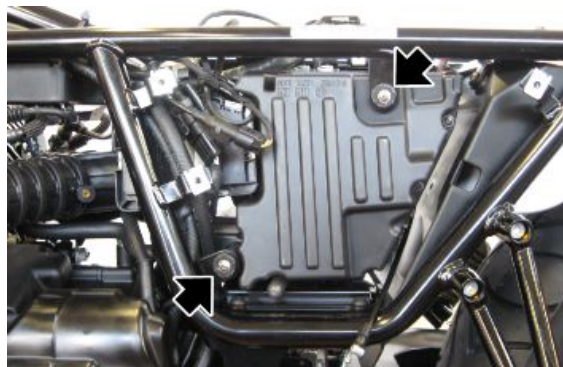
- Remove the air filter cover (4) and the filter (5)



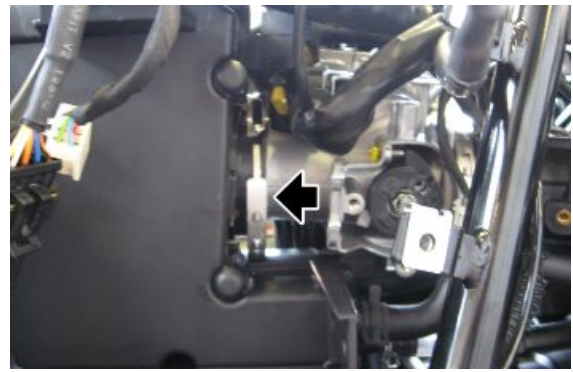
- Remove the two screws securing the fuse box support and move it to have greater freedom of movement for subsequent operations



- Remove the two screws that fasten the air filter case to the chassis



- Remove the clamp present in the collector that blocks the filter case to the throttle body



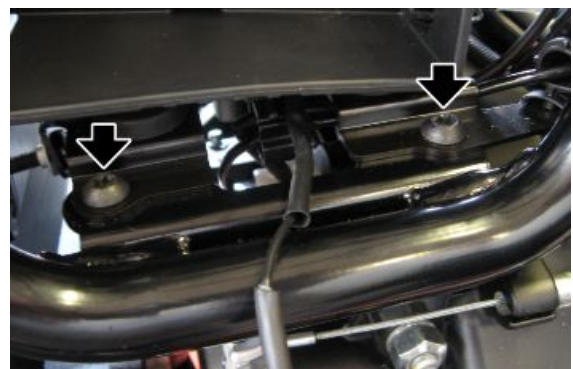
- Remove the two bottom fastening nuts of the splash guard



- Operating on the left side of the motorcycle, remove the blow-by pipe (6) from the filter case, while the right side, remove the secondary air pipe (7)



- Remove the four screws securing the filter case support bracket and remove it by slightly raising the box itself



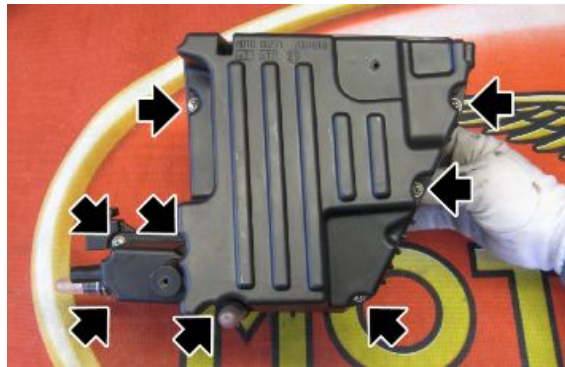
- Pull the filter case from the right side of the motorcycle



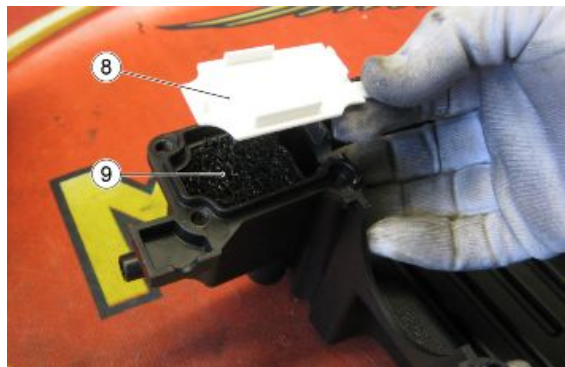
- Remove the collector from the filter case



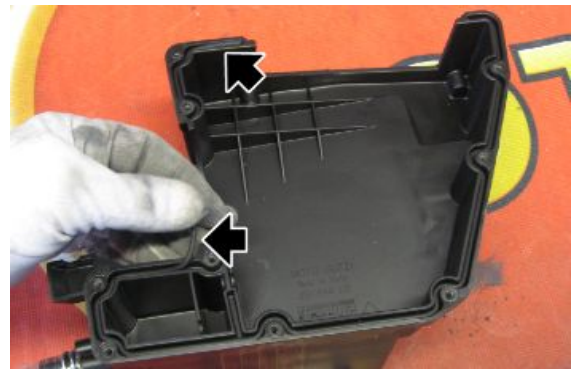
- Remove the locking screws from the filter case



- Remove the cover (8) and the blow-by filter (9)



- Check and replace the two seals present in the cover



INDEX OF TOPICS

PRE-DELIVERY

PRE DE

Carry out the listed checks before delivering the motorcycle.

WARNING

HANDLE FUEL WITH CARE.

Aesthetic inspection

- Paintwork
 - Fitting of Plastic Parts
 - Scratches
 - Dirt
-

Tightening torques inspection

- Safety fasteners:
 - front and rear suspension unit
 - front and rear brake calliper retainer unit
 - front and rear wheel unit
 - engine - chassis retainers
 - steering assembly
 - Plastic parts fixing screws
-

Electrical system

- Main switch
 - Headlamps: high beam lights, low beam lights, tail lights (front and rear) and their warning lights
 - Headlight adjustment according to regulations in force
 - Front and rear stop light switches and their bulbs
 - Turn indicators and their warning lights
 - Instrument panel lights
 - Instrument panel: fuel and temperature indicator (if present)
 - Instrument panel warning lights
 - Horn
 - Electric starter
 - Engine stop via emergency stop switch and side stand
 - Through the diagnosis tool, check that the last mapping version is present in the control unit/s and, if required, program the control unit/s again: consult the technical service website to know about available upgrades and details regarding the operation.
-

CAUTION

TO ENSURE MAXIMUM PERFORMANCE, THE BATTERY MUST BE CHARGED BEFORE USE. INADEQUATE CHARGING OF THE BATTERY WITH A LOW LEVEL OF ELECTROLYTE BEFORE IT IS FIRST USED SHORTENS BATTERY LIFE.

CAUTION

WHEN INSTALLING THE BATTERY, ATTACH THE POSITIVE LEAD FIRST AND THEN THE NEGATIVE ONE, AND PERFORM THE REVERSE OPERATION DURING REMOVAL.

CAUTION

THE BATTERY ELECTROLYTE IS TOXIC, CORROSIVE AND AS IT CONTAINS SULPHURIC ACID, IT CAN CAUSE BURNS WHEN IN CONTACT WITH THE SKIN. WHEN HANDLING BATTERY ELECTROLYTE, WEAR TIGHT-FITTING GLOVES AND PROTECTIVE APPAREL. IN THE EVENT OF SKIN CONTACT WITH THE ELECTROLYTIC FLUID, RINSE WELL WITH PLENTY OF CLEAN WATER. IT IS PARTICULARLY IMPORTANT TO PROTECT YOUR EYES BECAUSE EVEN TINY AMOUNTS OF BATTERY ACID MAY CAUSE BLINDNESS. IF THE FLUID GETS IN CONTACT WITH YOUR EYES, WASH WITH ABUNDANT WATER FOR FIFTEEN MINUTES AND CONSULT AN EYE SPECIALIST IMMEDIATELY. THE BATTERY RELEASES EXPLOSIVE GASES; KEEP IT AWAY FROM FLAMES, SPARKS, CIGARETTES OR ANY OTHER HEAT SOURCES. ENSURE ADEQUATE VENTILATION WHEN SERVICING OR RECHARGING THE BATTERY.

KEEP OUT OF THE REACH OF CHILDREN

BATTERY LIQUID IS CORROSIVE. DO NOT POUR IT OR SPILL IT, PARTICULARLY ON PLASTIC COMPONENTS. ENSURE THAT THE ELECTROLYTIC ACID IS COMPATIBLE WITH THE BATTERY TO BE ACTIVATED.

CAUTION

NEVER USE FUSES WITH A CAPACITY HIGHER THAN THE RECOMMENDED CAPACITY. USING A FUSE OF UNSUITABLE RATING MAY SERIOUSLY DAMAGE THE VEHICLE OR EVEN CAUSE A FIRE.

Levels check

- Hydraulic braking system fluid level
- Clutch system fluid level (if present)
- Gearbox oil level (if present)
- Transmission oil level (if present)
- Engine coolant level (if present)
- Engine oil level
- Mixer oil level (if present)

Road test

- Cold start
- Instrument panel operation

- Response to throttle control
 - Stability when accelerating and braking
 - Front and rear brake efficiency
 - Front and rear suspension efficiency
 - Abnormal noise
-

Static test

Static check after test drive:

- Restarting when warmed up
 - Starter operation (if present)
 - Minimum holding (turning the handlebar)
 - Uniform turning of the steering
 - Possible leaks
 - Radiator electric fan operation (if present)
-

Functional inspection

- Hydraulic braking system
- Stroke of brake and clutch levers (if present)
- Clutch - Check for correct operation
- Engine - Check for correct general operation and absence of abnormal noise
- Other
- Documentation check:
 - Chassis and engine numbers check
 - Supplied tools check
 - License plate fitting
 - Locks checking
 - Tyre pressure check
 - Installation of mirrors and any possible accessories



NEVER EXCEED THE RECOMMENDED INFLATION PRESSURES AS TYRES MAY BURST.
CAUTION



CHECK AND ADJUST TYRE PRESSURE WITH TYRES AT AMBIENT TEMPERATURE.

A

ABS: 150, 158

B

Battery: 82, 87

Brake: 163, 165, 167, 170, 172, 173, 176, 177

Brake calliper: 163, 165

Brake disc: 167, 170

Brake pads: 172, 173

Brake pump: 176, 177

Bulbs:

C

Clutch:

Connectors: 87

D

Diagnostics: 158

Display:

E

ECU: 95, 158

Electrical system: 12, 51, 52, 189

Engine oil: 43

Exhaust: 143, 147

Exhaust manifold: 147

F

Filter box:

Fork: 106, 108, 111, 113, 116

Front wheel: 122

Fuel:

Fuses: 86

G

Gearbox oil: 45

H

Handlebar: 103

I

Identification: 10

Instrument panel:

L

License plate holder: 183

M

Maintenance: 8, 41

Maintenance Table:

Mudguard:

O

Oil filter: 45

R

Rear wheel: 124

Recommended products: 34

S

Scheduled maintenance: 41

Shock absorbers: 118

Side stand:

Spark plugs:

Stand:

Start-up: 85

T

Tank:

Throttle body: 47

Transmission: 12, 42

Tyres: 14

U

Use: 158

W

Warning lights: